

Safety directional valves with spool position monitoring

On-off, pilot operated, conforming to Machine Directive 2006/42/EC

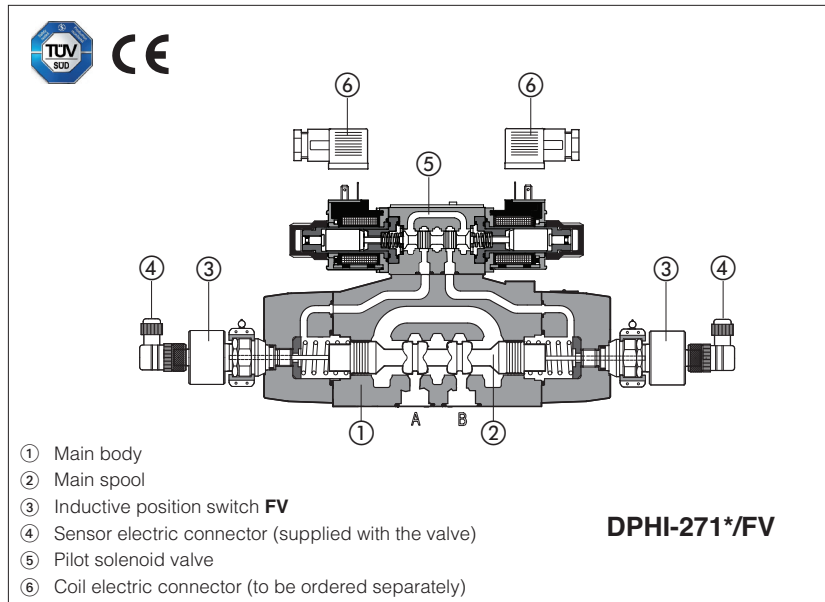

Pilot operated safety directional valves with main spool position monitoring, **CE** marked and certified by **TÜV** in accordance with safety requirements of Machine Directive 2006/42/EC.

Two models are available depending to the pilot valve execution:

DPHI for AC and DC supply, solenoid pilot valve ⑤ type DHI, with cURus certified solenoids, see tech. table E010

DPHE high performances, for AC and DC supply, solenoid pilot valve ⑤ type DHE with cURus certified solenoids, see tech. table E015

The valves are equipped with **FV** inductive position switch for the main spool position monitoring, see section ⑦ for sensor's technical characteristics.

Certification

The certificate **TÜV IT 12 MAC0021** can be downloaded from www.atos.com, catalog on line, technical information section.

Mounting surface: **ISO 4401, size 10, 16, 25**

Max flow: **160, 300, 700 l/min**

Max pressure: **350 bar**

1 MODEL CODE

DPH	I	- 2	71	1	/ A	/ FV	X	24DC	**	/ *
Pilot operated directional control valve										
<p>Solenoid pilot valve: I = DHI for AC and DC supply with cURus certified solenoids E = DHE for AC and DC supply, high performances with cURus certified solenoids</p>										
<p>Valve size, ISO 4401: 1 = 10 2 = 16 4 = 25</p>										
<p>Valve configuration, see section ②: 61 = single solenoid, center plus external position, spring centered 63 = single solenoid, 2 external positions, spring offset 67 = single solenoid, center plus external position, spring offset 71 = double solenoid, 3 positions, spring centered 75 = double solenoid, 2 external positions, with detent</p>										
<p>Spool type, see section ②</p>										
<p>Spool position monitor FV = inductive position switch (double contact)</p>										
<p>Hydraulic options, see section ⑤ A, D, E, R Optional devices for main spool switching control, see section ⑥ H, H9, L9</p>										
<p>X = without connector, see section ⑧ for available connectors, to be ordered separately</p>										
<p>Seals material see sect. ③, ④ - = NBR PE = FKM Series number</p>										
<p>Voltage code, see section ⑦</p>										











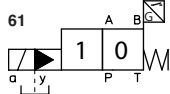
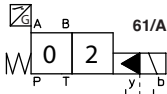
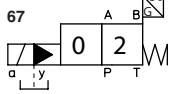
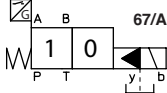
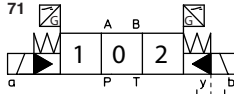
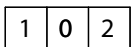
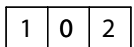
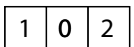
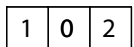

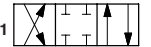

Notes:

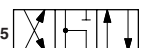
FV = inductive position switch providing both NO and NC contacts to be wired on the electric connector

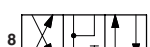
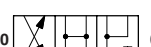
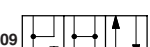
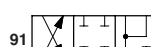
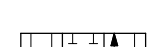
The FV inductive position switch is directly connected to the valve main spool

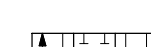
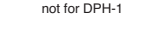
In pilot operated valves only the main spool position is monitored; the pilot solenoid valve is not monitored

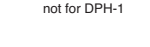
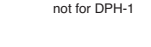
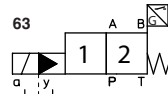
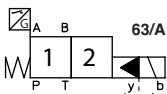
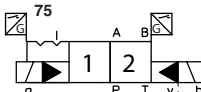
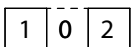
2 CONFIGURATIONS and SPOOLS (representation according to ISO 1219-1)

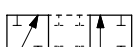
Configurations	Spoils	Configurations	Spoils
    	                       	  	   

Note: see also section 2.2 for special shaped spoils

2.1 Standard spoils availability

- DPH*-1 are available only with spoils **0, 0/2, 1, 1/2, 3, 4, 5, 58, 6, 7**
- DPH*-2 and DPH*-4 are available with all spoils shown in the above table

2.2 Special shaped spoils

- spoils type **0** and **3** are also available as **0/1** and **3/1** with restricted oil passages in central position, from user ports to tank.
- spoils type **1, 4, 5, 58, 6** and **7** are also available as **1/1, 4/8, 5/1, 58/1, 6/1** and **7/1** that are properly shaped to reduce water-hammer shocks during the switching.

2.3 Special spool availability

Valve size	special shaped spool							
	0/1	3/1	1/1	4/8	5/1	58/1	6/1	7/1
DPH*-1	•	•		•				
DPH*-2, DPH*-4	•	•	•	•	•	•	•	•

3 MAIN CHARACTERISTICS

Assembly position / location	Any position
Subplate surface finishing	Roughness index Ra 0,4 - flatness ratio 0,01/100 (ISO 1101)
MTTFd values according to EN ISO 13849	75 years, for further details see technical table P007
Ambient temperature	Standard = -30°C ÷ +70°C /PE option = -20°C ÷ +70°C
Flow direction	As shown in the symbols of table 2
Operating pressure	P, A, B, X = 350 bar (for pilot pressure see also option /L9 at section 6) T = 250 bar for external drain (standard) T with internal drain (option /D) = 120 bar DPHI; 210 bar DPHE (DC); 160 bar DPHE (AC) Y = 0 bar Minimum pilot pressure for correct operation is 8 bar
Maximum flow	DPH*-1: 160 l/min ; DPH*-2: 300 l/min ; DPH*-4: 700 l/min (see Q/Δp diagrams at section 12 and operating limits at section 13)

3.1 Coils characteristics

Insulation class	H (180°C) for DC coils (all versions) and AC coils (only DPHI) F (155°C) for AC coils (only DPHE) Due to the occurring surface temperatures of the solenoid coils, the European standards EN ISO 13732-1 and EN ISO 4413 must be taken into account
Protection degree to DIN EN 60529	IP 65 (with connectors correctly assembled)
Relative duty factor	100%
Supply voltage and frequency	See electric features 7
Supply voltage tolerance	± 10%
Certification	cURus North American standard

4 SEALS AND HYDRAULIC FLUID - for other fluids not included in below table, consult our technical office

Seals, recommended fluid temperature	NBR seals (standard) = -20°C ÷ +60°C, with HFC hydraulic fluids = -20°C ÷ +50°C FKM seals (/PE option) = -20°C ÷ +80°C		
Recommended viscosity	15 ÷ 100 mm ² /s - max allowed range 2,8 ÷ 500 mm ² /s		
Fluid contamination class	ISO 4406 class 21/19/16 NAS 1638 class 10, in line filters of 25 µm (β ₂₅ ≥ 75 recommended)		
Hydraulic fluid	Suitable seals type	Classification	Ref. Standard
Mineral oils	NBR, FKM	HL, HLP, HLPD, HVLP, HVLPD	DIN 51524
Flame resistant without water	FKM	HFDU, HFDR	ISO 12922
Flame resistant with water	NBR	HFC	

5 HYDRAULIC OPTIONS

5.1 option /A = Solenoid mounted at side of port A of main body (only for single solenoid valves)

In standard version the solenoid is mounted at side of port B

For sensor position, see sect 16

5.2 option /D = Internal drain (standard configuration is external drain)

5.3 option /E = External pilot pressure (standard configuration is internal pilot pressure)

5.4 option /R = Pilot pressure generator (4 bar on port P - not for DPH*-1)

The device /R generates an additional pressure drop, in order to ensure the minimum pilot pressure, for correct operation of the valves with internal pilot and fitted with spools type **0, 0/1, 4, 4/8, 5, 58, 09, 90, 94, 49**.

The device /R has to be fitted when the pressure drop in the valve, verified on flow versus pressure diagrams, is lower than the minimum pilot pressure value.

Pressure drop through the pilot pressure generator /R

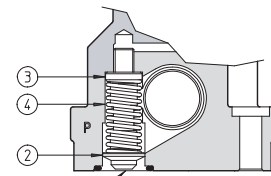
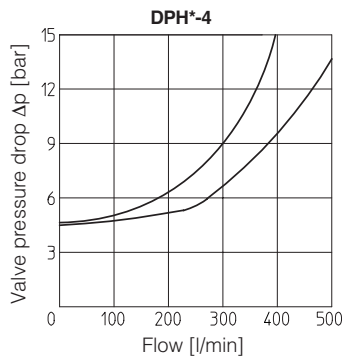
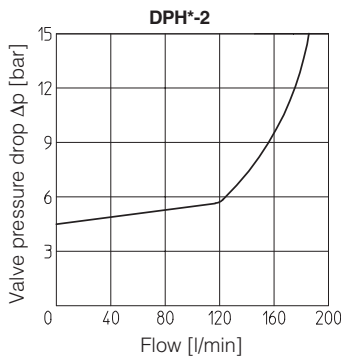

- ① Flapper-guide ③ Spring stop-washer
- ② Flapper ④ Spring

Ordering code of spare pilot pressure generator

R/DP	-	*
Pilot pressure generator		Size: 2 for DP-2 4 for DP-4

WARNING: the manual operation is not permitted for safety valves, than the valve is provided with solenoid blind rings to prevent the access to the manual override. The manual override protected by rubber cup (option /WP) is not available



WARNING: the inobservance of following prescriptions invalidates the certification and may represent a risk for personnel injury

Safety valves must be installed and commissioned only by qualified personnel

Safety valves must not be disassembled

The inductive position switch FV can be adjusted only by the valve's manufacturer or Atos authorized service centers

Valve's components cannot be interchanged

The valves must operate without switching shocks and spool vibrations



6 DEVICES FOR MAIN SPOOL SWITCHING CONTROL

Following options are suggested to reduce the hydraulic shocks at the valve operation

6.1 option /H = Adjustable chokes (meter-out to the pilot chambers of the main valve)

6.2 option /H9 = Adjustable chokes (meter-in to the pilot chambers of the main valve)

6.3 option /L9 = Only for DP-2 and DP-4: plug with calibrated restrictor in P port of pilot valve, suggested in case of pilot pressure higher than 210 bar or to limit the hydraulics shocks caused by the fast main spool switching

Plug code:

PLUG-12A ø1,2 mm for DP-2

PLUG-15A ø1,5 mm for DP-4

FUNCTIONAL SCHEME (config. 71)

example of switching control options

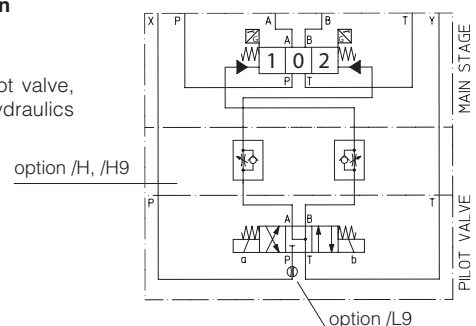

7 ELECTRIC FEATURES

Valve	External supply nominal voltage ± 10%	Voltage code	Type of connector	Power consumption (3)		Code of spare coil											
				DPHI	DPHE	DPHI	Colour of coil label	DPHE									
DPHI DPHE	6 DC	6 DC (4)	666 or 667	33 W	30 W	COU-6DC	brown	-									
	12 DC	12 DC				COU-12DC	green	COE-12DC									
	14 DC	14 DC				COU-14DC	brown	COE-14DC									
	24 DC	24 DC				COU-24DC	red	COE-24DC									
	28 DC	28 DC				COU-28DC	silver	COE-28DC									
	48 DC	48 DC				COU-48DC	silver	COE-48DC									
	110 DC	110 DC				COU-110DC	gold	COE-110DC									
	125 DC	125 DC				COU-125DC	blue	COE-125DC									
	220 DC	220 DC				COU-220DC	black	COE-220DC									
	24/50 AC	24/50/60 AC (4)				COI-24/50/60AC (1)	pink	-									
	24/60 AC					COI-48/50/60AC (1)	white	-									
	48/50 AC	48/50/60 AC (4)				60 VA	-	58 VA	COI-110/50/60AC (1)	yellow	COE-110/50/60AC						
	48/60 AC								-	80 VA	-	COE-115/60AC					
	110/50 AC	110/50/60 AC				60 VA	-	-	COI-120/60AC	white	-						
	115/60 AC (5)	115/60 AC	58 VA	COI-230/50/60AC (1)	light blue				COE-230/50/60AC								
	120/60 AC (4)	120/60 AC	60 VA	-	80 VA	COI-230/60AC	silver	COE-230/60AC									
	230/50 AC	230/50/60 AC				COU-110RC	gold	COE-110RC									
	230/60 AC	230/60 AC	669	33 W	30 W	COU-230RC	blue	COE-230RC									
	110/50 AC	110RC				669	33 W	30 W	COU-110RC	gold	COE-110RC						
	120/60 AC											230RC	669	33 W	30 W	COU-230RC	blue
230/50 AC																	
230/60 AC																	

(1) Coil can be supplied also with 60 Hz of voltage frequency: in this case the performances are reduced by 10÷15% and the power consumption is 55 VA (DPHI) and 58 VA (DPHE)

(2) Average values based on tests performed at nominal hydraulic condition and ambient/coil temperature of 20°C.

(3) When solenoid is energized, the inrush current is approx 3 times the holding current. Inrush current values correspond to a power consumption of about 150 VA.

(4) Only for DPHI
(5) Only for DPHE

8 COILS ELECTRIC CONNECTORS according to din 43650 (to be ordered separately)

666, 667 (for AC or DC supply)		669 (for AC supply)		CONNECTOR WIRING		
				666, 667 1 = Positive ⊕ 2 = Negative ⊖ ⊕ = Coil ground		669 1,2= Supply voltage VAC 3 = Coil ground
SUPPLY VOLTAGES						
666 All voltages		667 24 AC or DC 110 AC or DC 220 AC or DC		669 110/50 AC 110/60 AC 230/50 AC 230/60 AC		

9 TECHNICAL CHARACTERISTICS OF FV INDUCTIVE POSITION SWITCH

Type of switch	contactless inductive position switch with integrated amplifier		
Supply voltage [V]	20÷32		
Ripple max [%]	≤ 10		
Max current [mA]	400		
Reaction time [ms]	15		
Max peak pressure [bar]	400		
Mechanical life	virtually infinite		
Switch logic	PNP		

10 CONNECTING SCHEME OF FV INDUCTIVE POSITION SWITCH

single solenoid	double solenoid
<p>Connector type ZBE-06 (supplied with the valve)</p> <p>1 = supply +24 Vdc 2 = output signal NC 3 = GND 4 = output signal NO</p>	<p>Connector type ZBE-06 (supplied with the valve)</p> <p>1 = supply +24 Vdc 2 = output signal sol. b 3 = GND 4 = output signal sol. a</p>

Note: the /FV position switch is not provided with a protective earth connection

11 STATUS OF OUTPUT SIGNAL

DPHI - DPHE	Configuration 61	Configuration 63	Configuration 67	Configuration 71	Configuration 75
	monitored position "0"	monitored position "2"	monitored position "2"	monitored position "0"	monitored position "2"
Hydraulic configuration					
spool position	1 0	1 2	0 2	1 0 2	1 2
sensor	pin 2	ON	OFF	ON	OFF
	pin 4	OFF	ON	OFF	ON
sensor side a	pin 2	ON	OFF	ON	OFF
	pin 4	OFF	ON	OFF	ON
sensor side b	pin 2	ON	OFF	ON	OFF
	pin 4	OFF	ON	OFF	ON

Note:

FV position switch can be electrically wired by the customer as NO or NC and then the status of the output signal will be in accordance to the selected configuration

= intermediate spool position corresponding to the hydraulic configuration change

12 Q/Δp DIAGRAMS based on mineral oil ISO VG 46 at 50°C

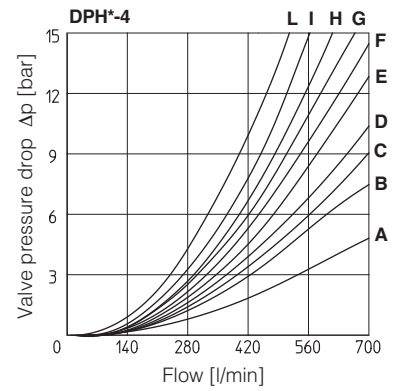
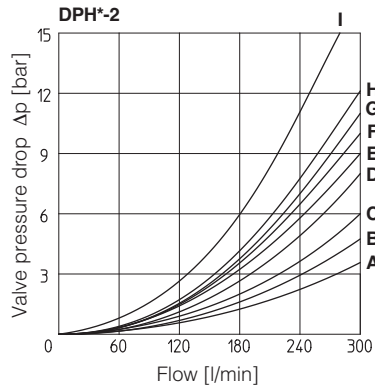
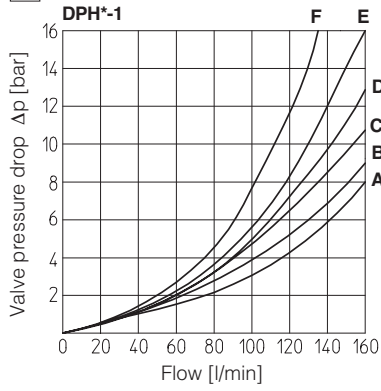

DPH*-1

Spool type	Flow direction				
	P→A	P→B	A→T	B→T	P→T
0/2, 1/2	D	E	D	C	-
0	D	E	C	C	E
1	A	B	D	C	-
3, 6, 7	A	B	C	C	-
4, 4/8	B	C	D	D	-
5, 58	A	E	C	C	F

DPH*-2

Spool type	Flow direction				
	P→A	P→B	A→T	B→T	P→T
0/2, 1, 3, 6, 7, 8	A	A	D	A	-
1/1, 1/2, 7/1	B	B	D	E	-
0	A	A	D	E	C
0/1	A	A	D	-	-
2	A	A	-	-	-
2/2	B	B	-	-	-
3/1	A	A	D	D	-
4	C	C	H	I	F
4/8	C	C	G	I	F
5	A	B	F	H	G
5/1	A	B	D	F	-
6/1	B	B	C	E	-
09	A	-	-	G	-
16	A	C	D	F	-
17	C	A	E	F	-
19	C	-	-	G	-
39	C	-	-	H	-
49	-	D	-	-	-
58	B	A	F	H	H
58/1	B	A	D	F	-
90	A	A	E	-	D
91	C	C	E	-	-
93	-	C	D	-	-
94	D	-	-	-	-

DPH*-4

Spool type	Flow direction				
	P→A	P→B	A→T	B→T	P→T
1	B	B	B	D	-
1/1	D	E	E	F	-
1/2	E	D	B	C	-
0	D	C	D	E	F
0/1, 3/1, 5/1, 6, 7	D	D	D	F	-
0/2	D	D	D	E	-
2	B	B	-	-	-
2/2	E	D	-	-	-
3	B	B	D	F	-
4	C	C	H	L	L
5	A	D	D	D	H
6/1	D	E	D	F	-
7/1	D	E	F	F	-
8	D	D	E	F	-
09	D	-	-	F	F
16	C	D	E	F	-
17	E	D	E	F	-
19	F	-	-	E	-
39	G	F	-	F	-
58	E	A	B	F	H
58/1	E	D	D	F	-
90	D	D	D	-	F
91	F	F	D	-	-
93	-	G	D	-	-

13 OPERATING LIMITS based on mineral oil ISO VG 46 at 50°C

For a correct valve operation do not exceed the max recommended flow rates (l/min) shown in the below tables

DPH*-1

Spool	Inlet pressure [bar]			
	70	160	210	350
	Flow rate [l/min]			
0, 1, 3, 6, 7	160	160	160	145
4, 4/8	160	160	135	100
5, 58	160	160	145	110
0/1, 0/2, 1/2	160	160	145	135

DPH*-2

Spool	Inlet pressure [bar]			
	70	140	210	350
	Flow rate [l/min]			
0, 1, 3, 6, 7, 8	300	300	300	300
2, 4, 4/8	300	300	240	140
5	260	220	180	100
0/1, 0/2, 1/2	300	250	210	180
16, 17, 56, *9, 9*	300	300	270	200

DPH*-4

Spool	Inlet pressure [bar]			
	70	140	210	350
	Flow rate [l/min]			
1, 6, 7, 8	700	700	700	600
2, 4, 4/8	500	500	450	400
5, 0/1, 0/2, 1/2	600	520	400	300
0, 3	700	700	600	540
16, 17, 58, *9, 9*	500	500	500	450

14 SWITCHING TIMES (average values in m sec)

TEST CONDITIONS:

- Nominal voltage supply DC (direct) and AC (alternating) with connector type SP-666. The use of other connectors can affect the switching time;
- 2 bar of counter pressure on port T;
- mineral oil: ISO VG 46 at 50°C

Piloting pressure		70 bar		140 bar		250 bar	
Valve model		Alternating current	Direct current	Alternating current	Direct current	Alternating current	Direct current
DPH*-1	Switch ON	35 ÷ 50	50 ÷ 75	30 ÷ 40	45 ÷ 65	20 ÷ 30	35 ÷ 50
	Switch OFF	50 ÷ 80					
DPH*-2	Switch ON	40 ÷ 55	55 ÷ 80	30 ÷ 45	50 ÷ 70	20 ÷ 35	40 ÷ 55
	Switch OFF	60 ÷ 95					
DPH*-4	Switch ON	60 ÷ 95	80 ÷ 115	45 ÷ 75	60 ÷ 95	30 ÷ 50	45 ÷ 65
	Switch OFF	80 ÷ 130					

15 PLUGS LOCATION FOR PILOT/DRAIN CHANNELS

Depending on the position of internal plugs, different pilot/drain configurations can be obtained as shown below. To modify the pilot/drain configuration, proper plugs must only be interchanged. The plugs have to be sealed using loctite 270.

Standard valves configuration provides internal pilot and external drain

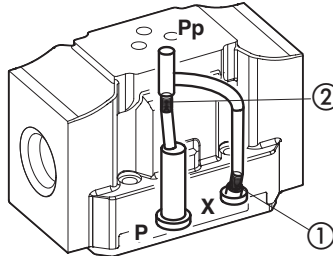
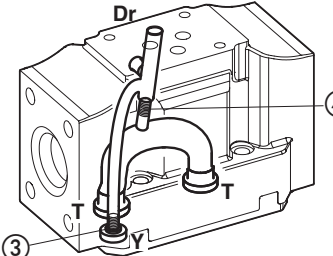
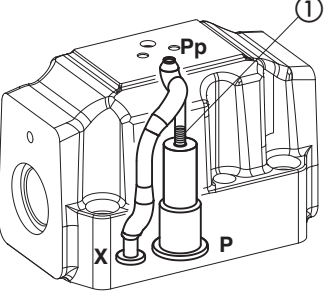
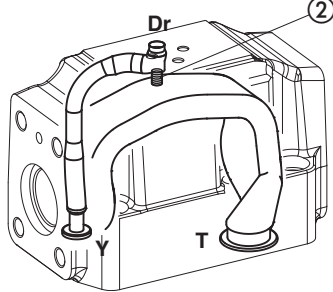
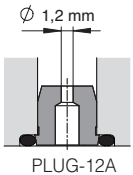
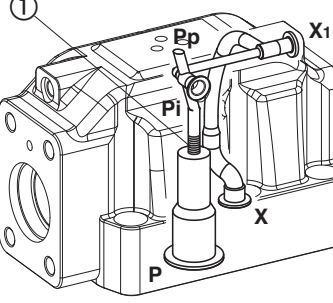
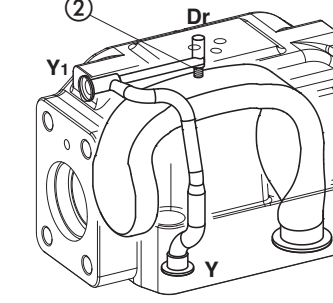
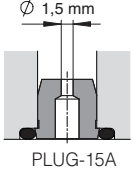
<p>DPH*-1</p> <p>Pilot channels</p> 	<p>Drain channels</p> 	<p>Internal piloting: blinded plug SP-X300F ① in X; plug SP-X310F ② in Pp;</p> <p>External piloting: blinded plug SP-X300F ② in Pp; plug SP-X310F ① in X;</p> <p>Internal drain: blinded plug SP-X300F ③ in Y;</p> <p>External drain: blinded plug SP-X300F ④ in Dr.</p>
<p>DPH*-2</p> <p>Pilot channels</p> 	<p>Drain channels</p> 	<p>Internal piloting: Without blinded plug SP-X300F ①;</p> <p>External piloting: Add blinded plug SP-X300F ①;</p> <p>Internal drain: Without blinded plug SP-X300F ②;</p> <p>External drain: Add blinded plug SP-X300F ②.</p> <p>Option L9 This option provides a calibrated restrictor PLUG-H-12A (Ø 1,2 mm) in the P port of the pilot valve</p>  <p>PLUG-12A</p>
<p>DPH*-4</p> <p>Pilot channels</p> 	<p>Drain channels</p> 	<p>Internal piloting: Without blinded plug SP-X500F ①;</p> <p>External piloting: Add blinded plug SP-X500F ①;</p> <p>Internal drain: Without blinded plug SP-X300F ②;</p> <p>External drain: Add blinded plug SP-X300F ②.</p> <p>Option L9 This option provides a calibrated restrictor PLUG-H-15A (Ø 1,5 mm) in the P port of the pilot valve</p>  <p>PLUG-15A</p>

16 DIMENSIONS of DPH* PILOT OPERATED SAFETY VALVES [mm]

DPH*-1/FV

ISO 4401: 2005
 Mounting surface:
 4401-05-05-0-05
 (without port X)

Fastening bolts:
 4 socket head screws M6x40 class 12.9
 Tightening torque = 15 Nm
 Seals: 5 OR 2050. 1 OR 108
 Ports P,A,B,T: $\varnothing = 11.5$ mm (max)
 Ports Y: $\varnothing = 5$ mm

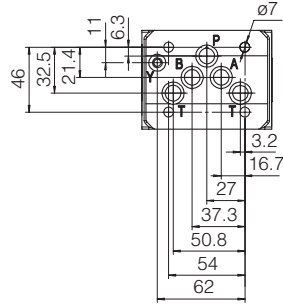

Mass (Kg)	
DPHI-16	7,1
DPHI-17	7,7
DPHE-16	7,2
DPHE-17	7,9
Option H, H9	+1,0

P = PRESSURE PORT
A, B = USE PORT
T = TANK PORT
Y = DRAIN PORT

DPH*-171*
DPH*-175*

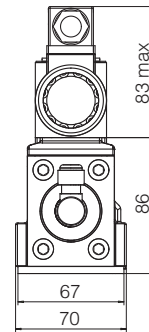
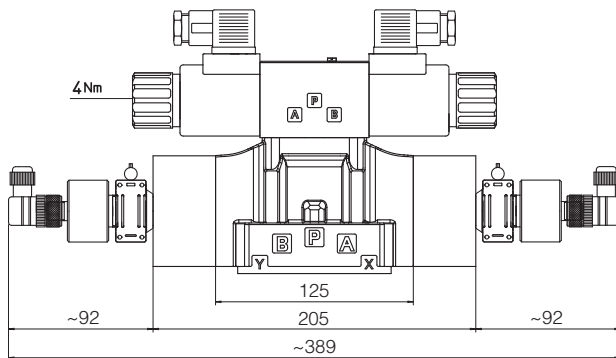

DPH*-161*

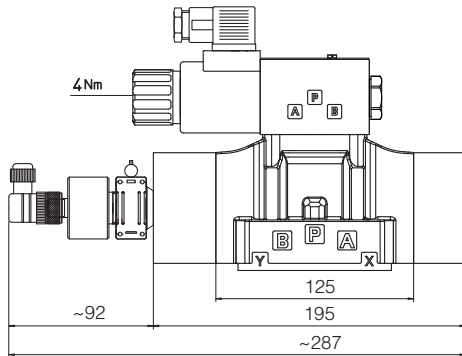

DPH*-161*/A

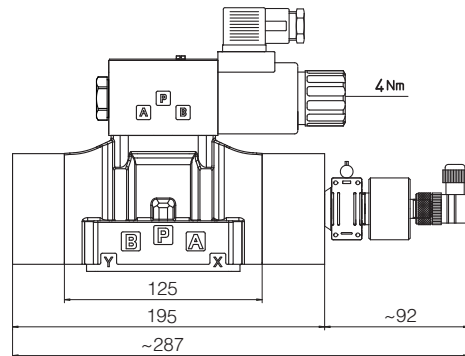

DPH*-163*
DPH*-167*

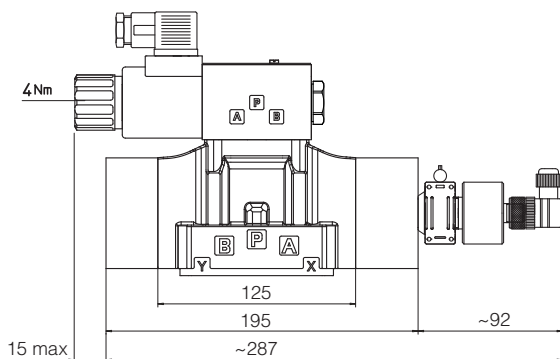

DPH*-163*/A
DPH*-167*/A

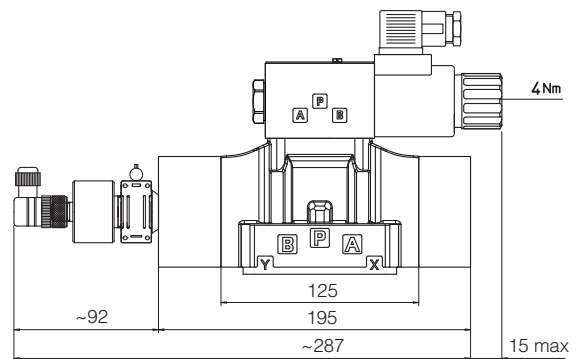

DPH*-2*/FV

ISO 4401: 2005

Mounting surface: 4401-07-07-0-05

Fastening bolts:

4 socket head screws M10x50 class 12.9

Tightening torque = 70 Nm

2 socket head screws M6x45 class 12.9

Tightening torque = 15 Nm

Diameter of ports A, B, P, T: $\varnothing = 20$ mm;

Diameter of ports X, Y: $\varnothing = 7$ mm;

Seals: 4 OR 130, 2 OR 2043

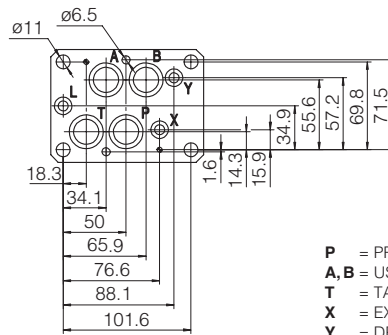

Mass (Kg)	
DPHI-26	10,1
DPHI-27	10,7
DPHE-26	10,2
DPHE-27	10,9
Option H, H9	+1,0

- P** = PRESSURE PORT
- A, B** = USE PORT
- T** = TANK PORT
- X** = EXTERNAL OIL PILOT PORT
- Y** = DRAIN PORT

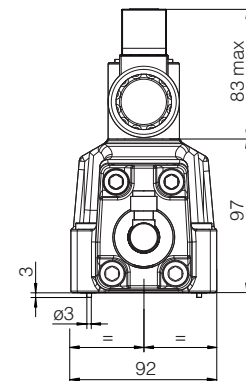
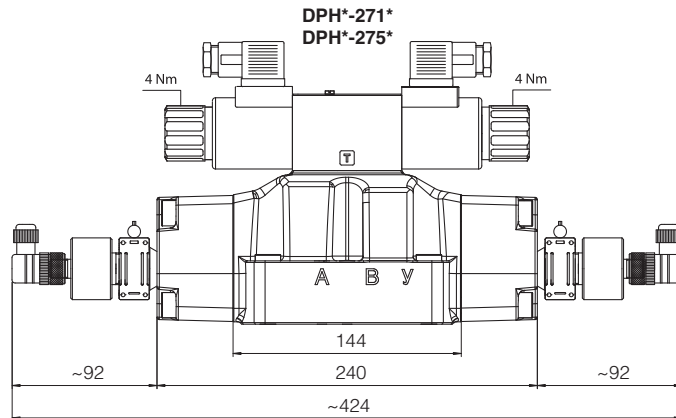

DPH*-261*

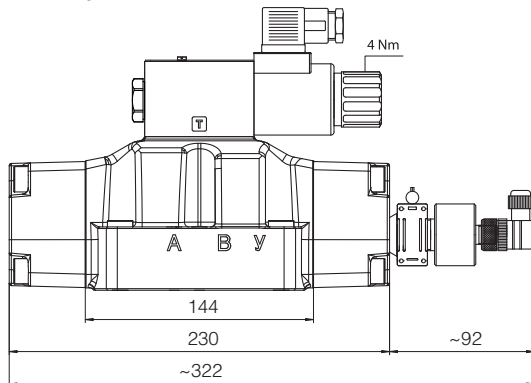

DPH*-261*/A

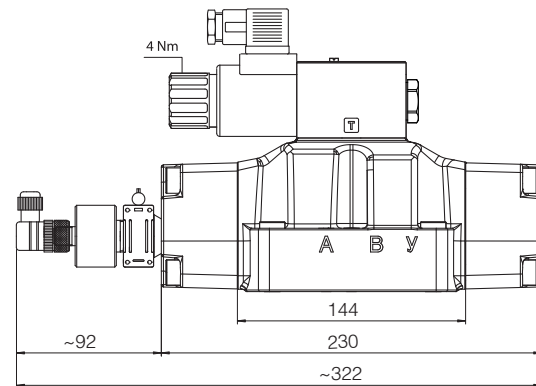

DPH*-263*
DPH*-267*

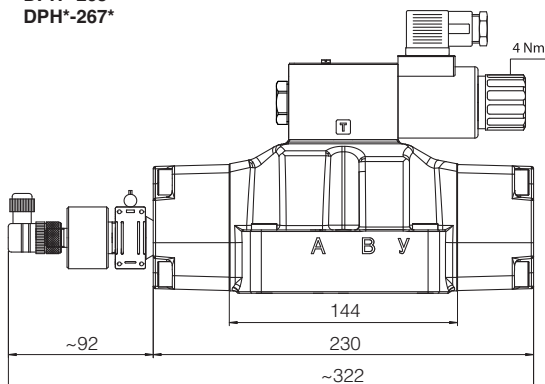

DPH*-263*/A
DPH*-267*/A

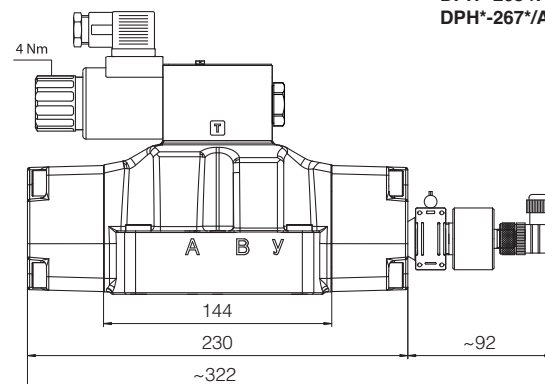

DPH*-4*/FV

ISO 4401: 2005

Mounting surface: 4401-08-08-0-05

Fastening bolts:
6 socket head screws M12x60 class 12.9
Tightening torque = 125 Nm
Diameter of ports A, B, P, T: $\varnothing = 24$ mm;
Diameter of ports X, Y: $\varnothing = 7$ mm;
Seals: 4 OR 4112, 2 OR 3056

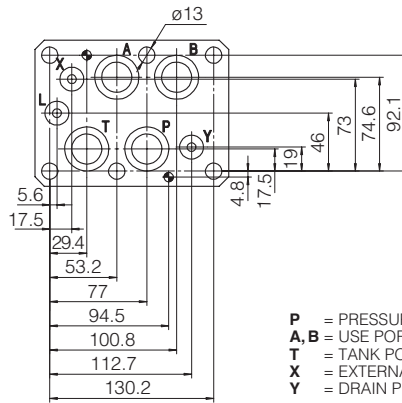

Mass (Kg)	
DPHI-46	17.6
DPHI-47	18.2
DPHE-46	17.7
DPHE-47	18.4
Option H, H9	+1,0

P = PRESSURE PORT
A, B = USE PORT
T = TANK PORT
X = EXTERNAL OIL PILOT PORT
Y = DRAIN PORT

DPH*-471* DPH*-475*

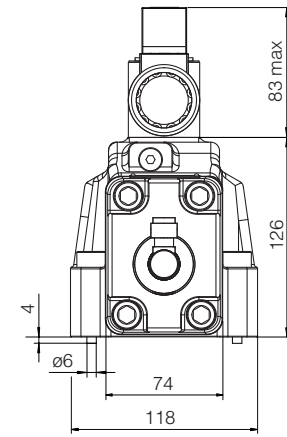
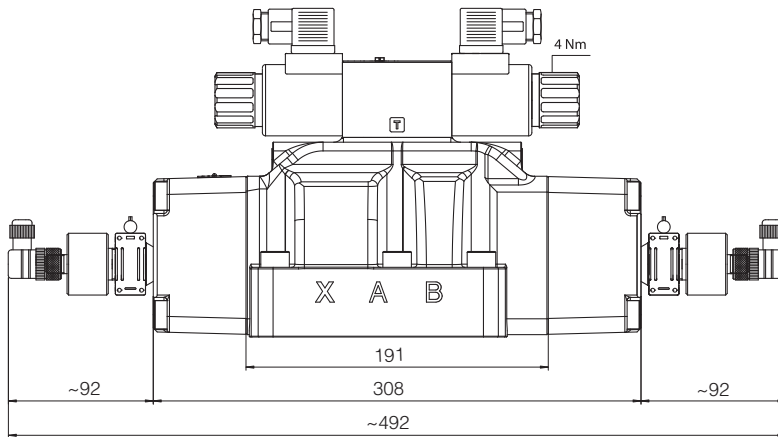

DPH*-461*

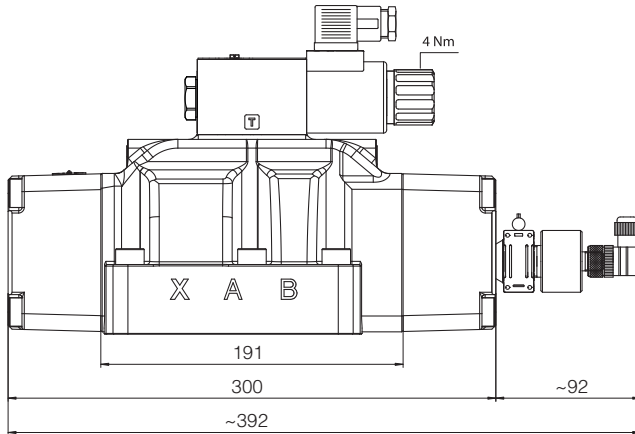

DPH*-461*/A

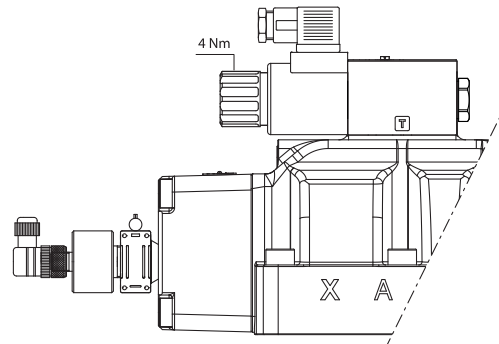

DPH*-463* DPH*-467*

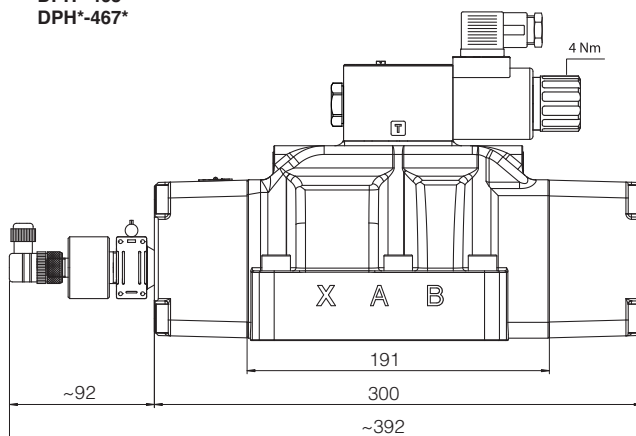

DPH*-463*/A DPH*-467*/A

