

Safety cartridge valves with poppet position monitoring

ISO standard, on-off, poppet type, conforming to Machine Directive 2006/42/EC

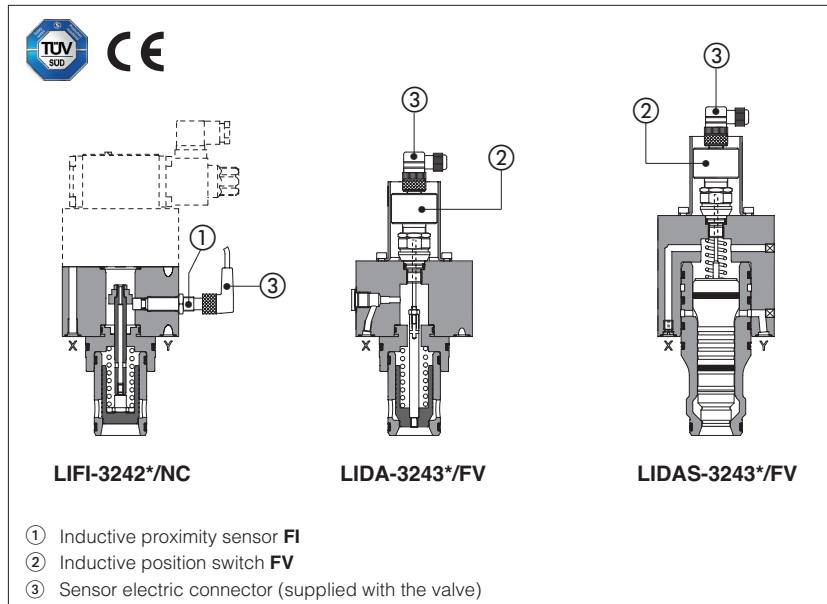

Safety cartridge valves with poppet position monitoring, **CE** marked and certified by **TÜV**, in accordance with safety requirements of Machine Directive 2006/42/EC.

LIFI: intermediate safety element with **FI** inductive proximity sensor, to be coupled with functional covers

LIDA: safety valve with integral cover design and with **FV** inductive position switch, available with optional solenoid pilot valve (**LIDASH**)

LIDAS: active pilot operated safety valve with **FV** inductive position switch, available with optional solenoid pilot valve (**LIDASH**), see section [1] for sensors technical characteristics.

These valves are normally used to cut off the hydraulic power line in case of emergency condition, thus avoiding dangerous movements of the machines actuators.

Certification

The certificate **TÜV IT 12 MAC0021** can be downloaded from www.atos.com, catalog on line, technical information section.

Mounting surface & cavity:

ISO 7368 size **16 to 50**

Max flow: up to **2000 l/min**

Max pressure: **LIFI 315 bar**

LIDA, LIDAS 350 bar

1 RANGE OF VALVE'S MODELS

Valve code	Size	Description	DC solenoids		AC solenoids	
			Sensor type			
			/FI	/FV	/FI	/FV
LIFI	16÷50	intermediate elements with cartridge, to be coupled with a functional cover	•		•	
LIDA(H)	16÷50	cartridges valve		•		•
LIDAS(H)	16÷50	active cartridges valve		•		•

Notes: **FI** = inductive proximity sensor, type NO (normally open or NC (normally closed)

FV = inductive position switch providing both NO and NC contacts to be wired on the electric connector

See section [3] for sensor's characteristics

2 MODEL CODE OF LIFI INTERMEDIATE SAFETY ELEMENT - to be coupled with covers in section [3]

<p style="text-align: center; font-weight: bold; font-size: 1.2em;">LIF</p> <p>Intermediate safety element and cartridge according to ISO 7368</p> <p>Poppet position monitor: I = inductive proximity switch</p> <p>Size ISO 7368 16; 25; 32; 40; 50 Other dimensions available on request</p> <p>Type of poppet, see sect. [9] for Q/Δp diagrams 42 = with damping nose, area ratio 1:1,1 43 = with damping nose, area ratio 1:2 (for size 16 and 25) 1:1,6 (for size 32, 40 and 50)</p>	I - 25	42	1 / NC	** /	<div style="border: 1px solid black; padding: 2px; text-align: center; font-weight: bold; font-size: 1.2em;">*</div> <p>Seals material: omit for NBR (mineral oil & water glycol) PE = FKM</p> <p>Series number</p> <p>/NC = closed contact with poppet in resting position</p>
---	--------	----	--------	------	---

Spring cracking pressure:
1 = 0,3 bar for poppet 42; 0,6 bar for poppet 43
2 = 1,5 bar for poppet 42
3 = 3 bar for all poppets
6 = 5,5 bar for all poppets

2.1 Hydraulic symbols of LIFI

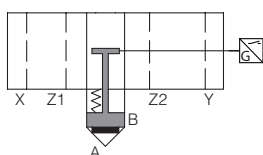

Note: in LIFI safety valves the cartridge and the intermediate element with poppet position sensor cannot be separated

3 MODEL CODE OF FUNCTIONAL COVERS TO BE COUPLED WITH LIFI SAFETY VALVES

<p>LID</p> <p>Cover according to ISO 7368</p> <p>Cover type, see section 3.1 for hydraulic configuration:</p> <p>A = direct pilot B = with shuttle valve for pilot selection; EW* = with solenoid valve for pilot selection BH** = as EW* but with shuttle valve for pilot selection;</p> <p>Size ISO 7368 1 = 16; 2 = 25; 3 = 32; 4 = 40; 5 = 50;</p> <p>E = with external attachment X (1/4" GAS) and underneath port X plugged</p> <p>F = prearranged for coupling with LIFI cover</p>	<p>A</p>	<p>-</p>	<p>2</p>	<p>/</p>	<p>E</p>	<p>-</p>	<p>I</p>	<p>X</p>	<p>24DC</p>	<p>**</p>	<p>/</p>	<p>*</p>	<p>/</p>	<p>*</p>
<p>Special execution of the calibrated plugs in the pilot channels (see tables H030, H040)</p> <p>Seals material: omit for NBR (mineral oil & water glycol) PE = FKM</p> <p>Series number</p> <p>Voltage code only for LIDBH** and LIDEW*: see section 10</p> <p>Only for LIDBH** and LIDEW*: X = without connector, to be order separately see section 11</p> <p>Type of pilot solenoid valve only for LIDAH: -I = DHI for AC and DC supply with cURus certified solenoids -E = DHE for AC and DC supply high performances, with cURus certified solenoids</p>														

For valve type LIDB, LIDEW (in the configuration with external pilot line) Atos can supply leak free poppet type directional pilot valves type DLEH-3*. Consult our technical office for detailed information.

3.1 HYDRAULIC SYMBOLS OF FUNCTIONAL COVERS

the following symbols show the functional covers coupled with intermediate safety element type LIFI

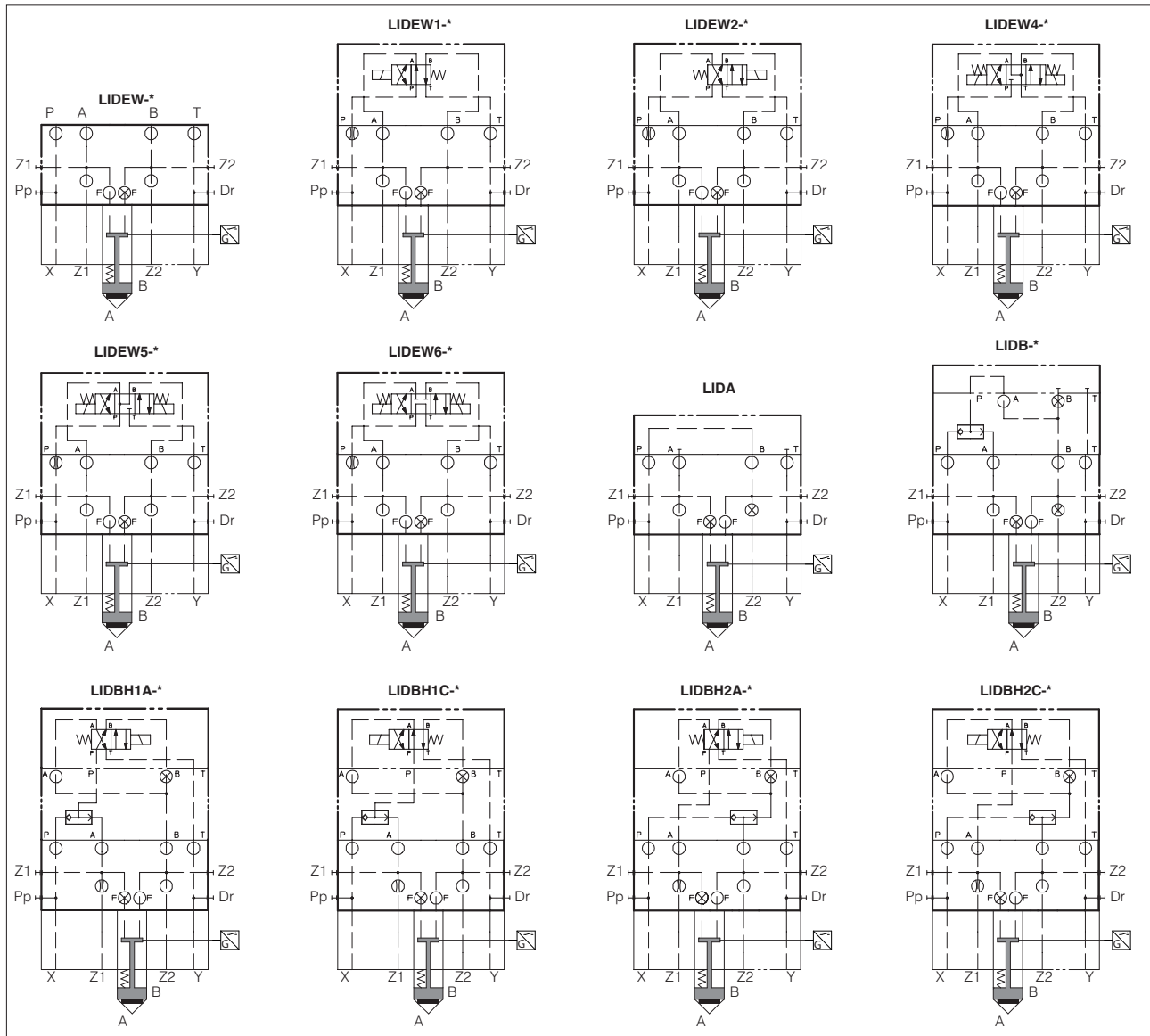

4 MODEL CODE OF LIDA SAFETY VALVES (integral design cover)

LIDA	H	-	25	43	3	/	FV	-	I	X	24DC	**	/	*
Safety cartridge valve according to ISO 7368														Seals material: omit for NBR (mineral oil & water glycol) PE = FKM
<p>optional pilot valve: - = omit if not required H = with NG 6 pilot valve</p>														
<p>Size ISO 7368: 16; 25; 32; 40; 50</p>														
<p>poppet type: 43 = with damping nose area ratio 1:2 (size 16 and 25) 1:1,6 (size 32, 40 and 50)</p>														
<p>spring cracking pressure: 1 = 0,6 bar 3 = 3 bar 6 = 5,5 bar</p>														
<p>Poppet position monitor: FV = inductive position switch (double contact)</p>														
<p>Only for LIDAH Voltage code, see section 10</p>														
<p>Only for LIDAH X = without connector, to be order separately see section 11</p>														
<p>Pilot solenoid valve only for LIDAH I = DHI for AC and DC supply, with cURus certified solenoids E = DHE for AC and DC supply, high performances, with cURus certified solenoids</p>														

4.1 HYDRAULIC SYMBOLS OF LIDA /FV

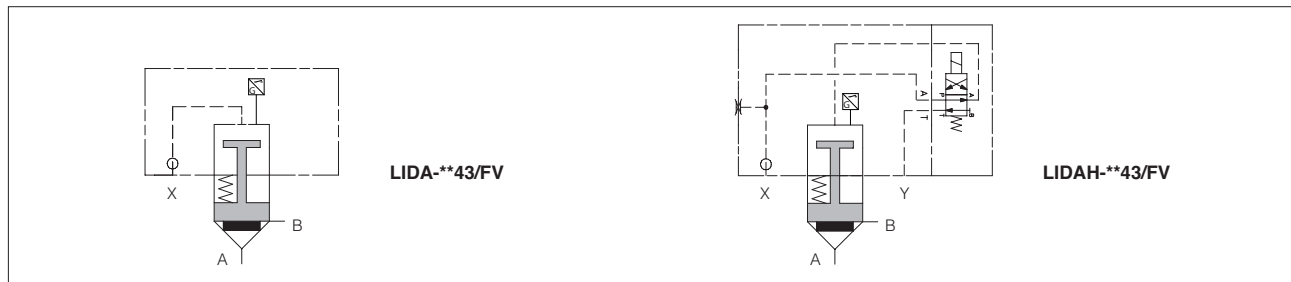

5 MAIN CHARACTERISTICS OF LIFI AND LIDA(H)/FV

Assembly position / location		Any position				
Subplate surface finishing		Roughness index Ra 0,4 - flatness ratio 0,01/100 (ISO 1101)				
MTTFd values according to EN ISO 13849		75 years, for further details see technical table P007				
Ambient temperature		Standard = -30°C ÷ +70°C /PE option = -20°C ÷ +70°C				
Flow direction		A→B or B→A				
Operating pressure	LIFI	A, B, X, Z1, Z2 = 315 bar				
	LIDA/FV	A, B, X = 350 bar ; Y = LIDAH-I 120 bar ; LIDAH-E (DC) 210 bar ; LIDAH-E (AC) 160 bar ;				
Size		16	25	32	40	50
Maximum flow at Δp = 6 bar [l/min]	LIFI					
	LIFI, LIDA/FV	poppet 42	150	320	600	1250
	LIFI, LIDA/FV	poppet 43	130	300	480	940
					1250	1500

5.1 POPPET CHARACTERISTICS OF LIFI AND LIDA(H)/FV

Poppet type	42 (only LIFI)	43	
Functional sketch (Hydraulic symbol)			
Area ratio A/AAP	1:1,1	1:2 for size 16, 25	1 : 1,6 for size 32 ÷ 50
Opening pressure A→B (1)	0,3bar (spring 1) 1,3bar (spring 2) 3,2bar (spring 3) 6 bar (spring 6)	0,5bar (spring 1) - 2,7bar (spring 3) 6 bar (spring 6)	0,4bar (spring 1) - 2,5bar (spring 3) 4,9bar (spring 6)
Opening pressure B→A (1)	3 bar (spring 1) 12,8bar (spring 2) 32,5bar (spring 3) 59,4bar (spring 6)	0,5bar (spring 1) - 2,4bar (spring 3) 6 bar (spring 6)	0,7bar (spring 1) - 3,7bar (spring 3) 7,5bar (spring 6)

(1) Depending on the spring cracking pressure and the area ratio of the poppet

6 MODEL CODE OF LIDAS ACTIVE SAFETY PILOT OPERATED VALVES

<p>LIDAS</p> <p>Active safety cartridges, according to ISO 7368</p> <p>Optional pilot valve:</p> <p>- = without pilot solenoid valve</p> <p>H = with pilot solenoid valve</p> <p>Size ISO 7368:</p> <p>16; 25; 32; 40; 50</p> <p>Poppet type:</p> <p>43 = with damping nose</p> <p>Spring cracking pressure</p> <p>3 = 3 bar</p> <p>Poppet position monitor:</p> <p>FV = inductive position switch (double contact)</p>	<p>H - 40 43 3 / FV - I X 24DC ** / *</p>	<p>Seals material: omit for NBR (mineral oil & water glycol) PE = FKM</p> <p>Series number</p> <p>Only for LIDASH voltage code, see section 10</p> <p>Only for LIDASH X = without connector, to be order separately see section 11</p> <p>Pilot solenoid valve only for LIDASH</p> <p>I = DHI for AC and DC supply, with cURus certified solenoids</p> <p>E = DHE for AC and DC supply, high performances, with cURus certified solenoids</p>
--	---	--

6.1 HYDRAULIC SYMBOLS OF LIDAS

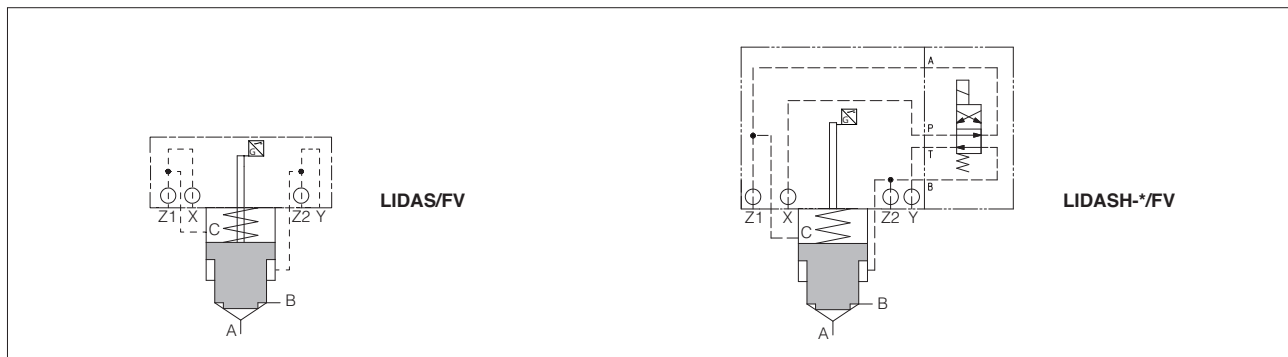

7 MAIN CHARACTERISTICS OF LIDAS/FV

Assembly position / location	Any position				
Subplate surface finishing	Roughness index Ra 0,4 - flatness ratio 0,01/100 (ISO 1101)				
MTTFd values according to EN ISO 13849	150 years, for further details see technical table P007				
Ambient temperature	Standard = -30°C ÷ +70°C /PE option = -20°C ÷ +70°C				
Flow direction	A→B or B→A				
Operating pressure	LIDAS/FV	A, B, X, Z1, Z2 = 350 bar			
	LIDASH/FV	A, B, X, Z1, Z2 = 350 bar ; Y = LIDASH-I 120 bar ; LIDASH-E (DC) 210 bar ; LIDASH-E (AC) 160 bar ;			
Size	16	25	32	40	50
Maximum flow at Δp = 6 bar [l/min]	220	400	600	1300	2000
Poppet characteristics [cm ²]					
AA	1,43	3,46	5,30	8,04	13,85
AB (% of AA)	58,6	41,7	51,5	56,3	41,7
ABP (% of AA)	107,0	90,5	85,2	87,9	97,8
AAP (% of AA)	265,6	232,2	236,7	244,1	239,2
AA / (AA + AB) poppet ratio	0,6				
AAP / (AA + AB) piloting ratio	1,6				

7.1 Poppet areas of LIDAS/FV

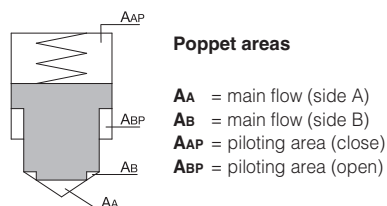

Thanks to the areas ratio $AAP/(AA+AB)$, the valve closing is always ensured with a piloting pressure (X port) equal to the line pressure (A or B line).

8 COILS CHARACTERISTICS

Insulation class	H (180°C) for DC coils (all versions) and AC coils (only DHI) F (155°C) for AC coils (DHE) Due to the occurring surface temperatures of the solenoid coils, the European standards EN ISO 13732-1 and EN ISO 4413 must be taken into account
Protection degree to DIN EN 60529	IP 65 (with connectors correctly assembled)
Relative duty factor	100%
Supply voltage and frequency	See electric feature 7
Supply voltage tolerance	± 10%
Certification	cURus North American standard

9 SEALS AND HYDRAULIC FLUID - for other fluids not included in below table, consult our technical office

Seals, recommended fluid temperature	NBR seals (standard) = -20°C ÷ +60°C, with HFC hydraulic fluids = -20°C ÷ +50°C FKM seals (/PE option) = -20°C ÷ +80°C		
Recommended viscosity	15 ÷ 100 mm ² /s - max allowed range 2,8 ÷ 500 mm ² /s		
Fluid contamination class	ISO 4406 class 21/19/16 NAS 1638 class 10, in line filters of 25 µm (β ₂₅ ≥ 75 recommended)		
Hydraulic fluid	Suitable seals type	Classification	Ref. Standard
Mineral oils	NBR, FKM	HL, HLP, HLPD, HVLP, HVLPD	DIN 51524
Flame resistant without water	FKM	HFDR, HFDR	ISO 12922
Flame resistant with water	NBR	HFC	

10 ELECTRIC FEATURES - coils for pilot solenoid valves

Valve	External supply nominal voltage ± 10%	Voltage code	Type of connector	Power consumption (3)		Code of spare coil		
				DHI	DHE	DHI	Colour of coil label	DHE
DHI DHE	6 DC	6 DC (4)	666 or 667	33 W	30 W	COU-6DC	brown	-
	12 DC	12 DC				COU-12DC	green	COE-12DC
	14 DC	14 DC				COU-14DC	brown	COE-14DC
	24 DC	24 DC				COU-24DC	red	COE-24DC
	28 DC	28 DC				COU-28DC	silver	COE-28DC
	48 DC	48 DC				COU-48DC	silver	COE-48DC
	110 DC	110 DC				COU-110DC	gold	COE-110DC
	125 DC	125 DC				COU-125DC	blue	COE-125DC
	220 DC	220 DC				COU-220DC	black	COE-220DC
	24/50 AC	24/50/60 AC				COI-24/50/60AC (1)	pink	-
	24/60 AC	(4)	COI-48/50/60AC (1)	white	-			
	48/50 AC	48/50/60 AC	COI-110/50/60AC (1)	yellow	COE-110/50/60AC			
	48/60 AC	(4)						
	110/50 AC	110/50/60 AC	-	80 VA	COE-115/60AC			
	115/60 AC (5)	115/60 AC	60 VA	-	COI-120/60AC	white	-	
	120/60 AC (4)	120/60 AC			58 VA	COI-230/50/60AC (1)	light blue	COE-230/50/60AC
	230/50 AC	230/50/60 AC			80 VA	COI-230/60AC	silver	COE-230/60AC
	230/60 AC	230/60 AC	669	33 W	30 W	COU-110RC	gold	COE-110RC
	110/50 AC	110RC				COU-230RC	blue	COE-230RC
	120/60 AC							
230/50 AC								
230/60 AC								

(1) Coil can be supplied also with 60 Hz of voltage frequency: in this case the performances are reduced by 10÷15% and the power consumption is 55 VA (-I) and 58 VA (-E)

(2) Average values based on tests performed at nominal hydraulic condition and ambient/coil temperature of 20°C.

(3) When solenoid is energized, the inrush current is approx 3 times the holding current. Inrush current values correspond to a power consumption of about 150 VA.

(4) Only for pilot valve DHI

(5) Only for pilot valve DHE

11 COILS ELECTRIC CONNECTORS FOR PILOT SOLENOID VALVES according to DIN 43650 (to be ordered separately)

666, 667 (for AC or DC supply)		669 (for AC supply)		CONNECTOR WIRING	
				666, 667 1 = Positive ⊕ 2 = Negative ⊖ ⊕ = Coil ground	
				669 1,2= Supply voltage VAC 3 = Coil ground	
SUPPLY VOLTAGES					
666 All voltages		667 24 AC or DC 110 AC or DC 220 AC or DC		669 110/50 AC 110/60 AC 230/50 AC 230/60 AC	

12 TECHNICAL CHARACTERISTICS OF INDUCTIVE PROXIMITY AND POSITION SWITCHES

Valve type	LIFI	/FI scheme	LIDA*/FV, LIDAS*/FV	/FV scheme
Type of switch	/FI proximity sensor		/FV proximity switch	
Supply voltage [V]	10÷30	1 output signal	20÷32	1 supply +24 VDC
Ripple max [%]	≤ 20	2 supply +24 VDC	≤ 10	2 output signal
Max current [mA]	200	4 GND	400	3 GND
Max peak pressure [bar]	500		400	4 output signal
Mechanical life	virtually infinite		virtually infinite	
Switch logic	PNP		PNP	

13 CONNECTING SCHEMES OF FI INDUCTIVE PROXIMITY AND FV POSITION SWITCHES

LIFI	LIDA*/FV, LIDAS*/FV
Connector type BKS-B-20-4-03	Connector type ZBE-06 IP65
black = output signal brown = supply +24 VDC blue = GND CABLE LENGHT = 3 m	1 = supply +24 VDC 2 = output signal NC 3 = GND 4 = output signal NO

Notes:

- FI and FV sensor's connector are always supplied with the valve
- The /FI and /FV sensors are not provided with a protective earth connection

14 STATUS OF OUTPUT SIGNALS

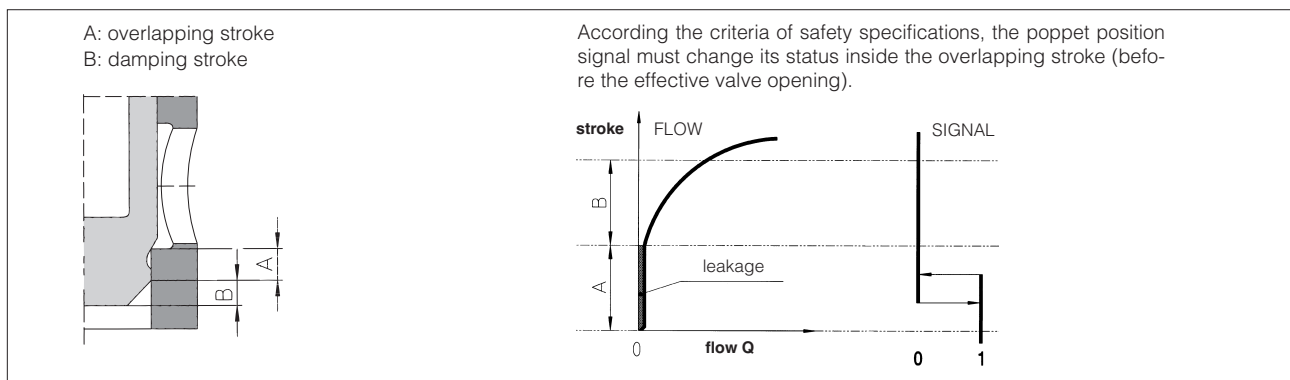

WARNING: the inobservance of following prescriptions invalidates the certification and may represent a risk for personnel injury



- Safety valves must be installed and commissioned only by qualified personnel
- Safety valves must not be disassembled
- The inductive proximity FI or the inductive position switch FV can be adjusted only by the valve's manufacturer or Atos authorized service centers
- Valve's components cannot be interchanged
- The valves must operate without switching shocks and spool vibrations

15 Q/Δp DIAGRAMS based on mineral oil ISO VG 46 at 50 °C

15.1 Q/Δp DIAGRAMS OF LIFI AND LIDA/FV

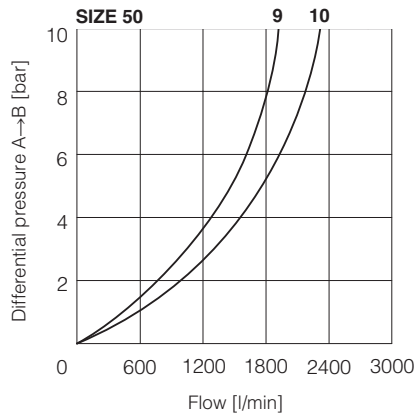
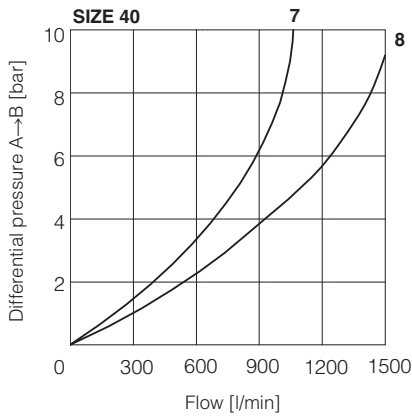
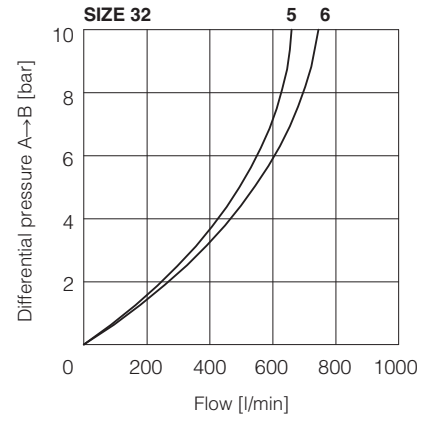
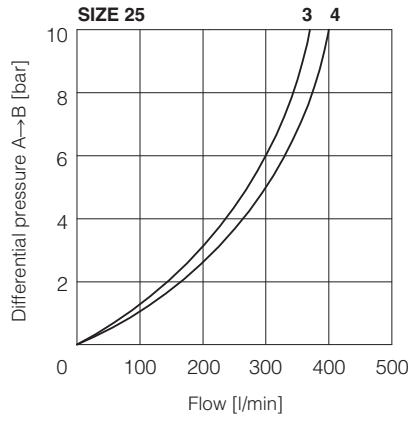
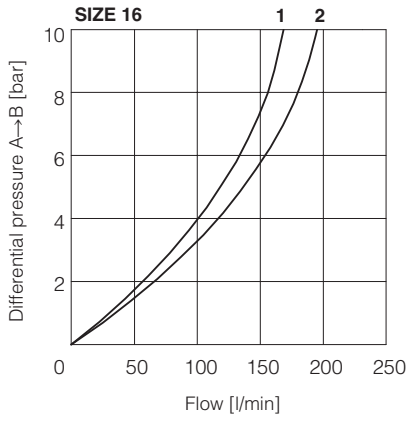

- 1** = LIFI-1643, LIDA-1643
- 2** = LIFI-1642
- 3** = LIFI-2543, LIDA-2543
- 4** = LIFI-2542
- 5** = LIFI-3243, LIDA-3243
- 6** = LIFI-3242
- 7** = LIFI-4043, LIDA-4043
- 8** = LIFI-4042
- 9** = LIFI-5043, LIDA-5043
- 10** = LIFI-5042

15.2 Q/Δp DIAGRAMS OF LIDAS/FV

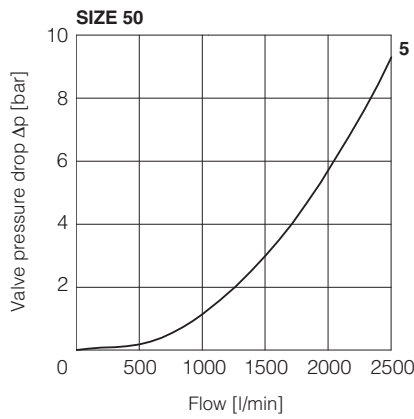
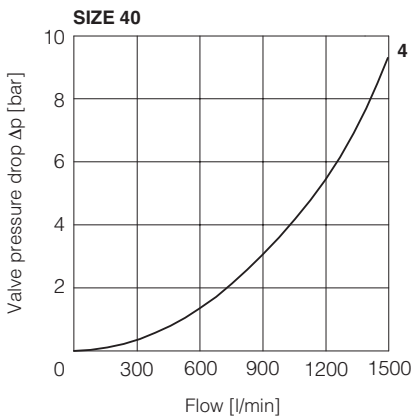
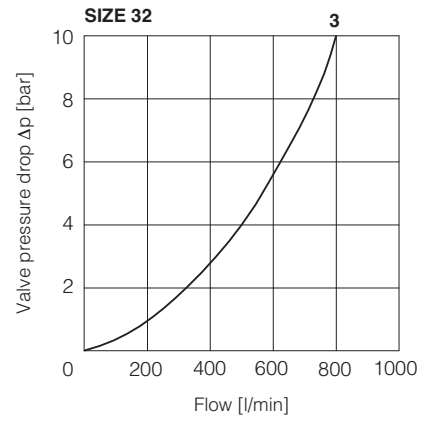
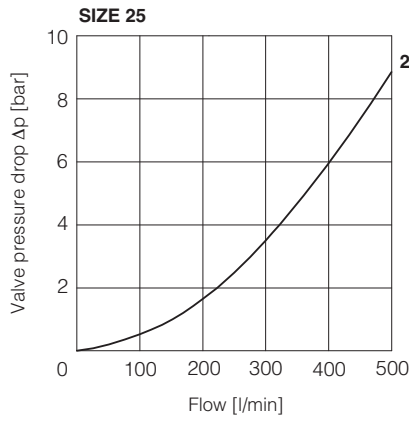
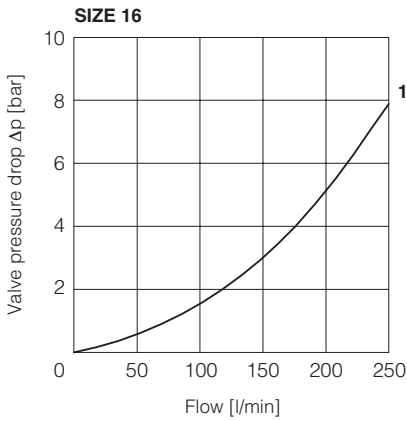

- 1** = LIDAS*-1643
- 2** = LIDAS*-2543
- 3** = LIDAS*-3243
- 4** = LIDAS*-4043
- 5** = LIDAS*-5043

16 DIMENSIONS of LIFI SAFETY COVERS [mm]

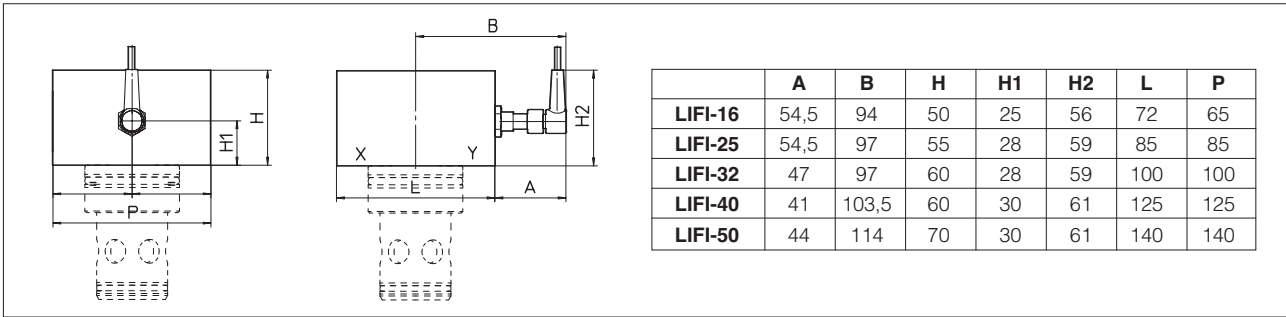

Note: for cover interface and cavity dimensions ISO 7368, see table P006

17 EXAMPLES OF LIFI COUPLED WITH OTHER COVERS (examples in size 32)

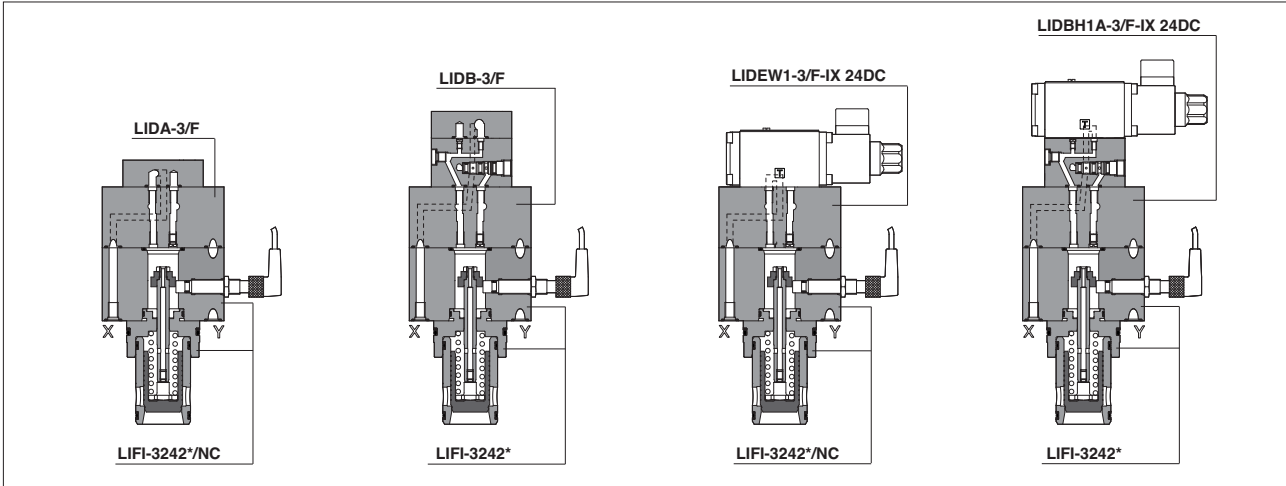

18 INSTALLATION DIMENSIONS of LIDA*/FV and LIDAS*/FV SAFETY CARTRIDGES [mm] (examples in size 32)

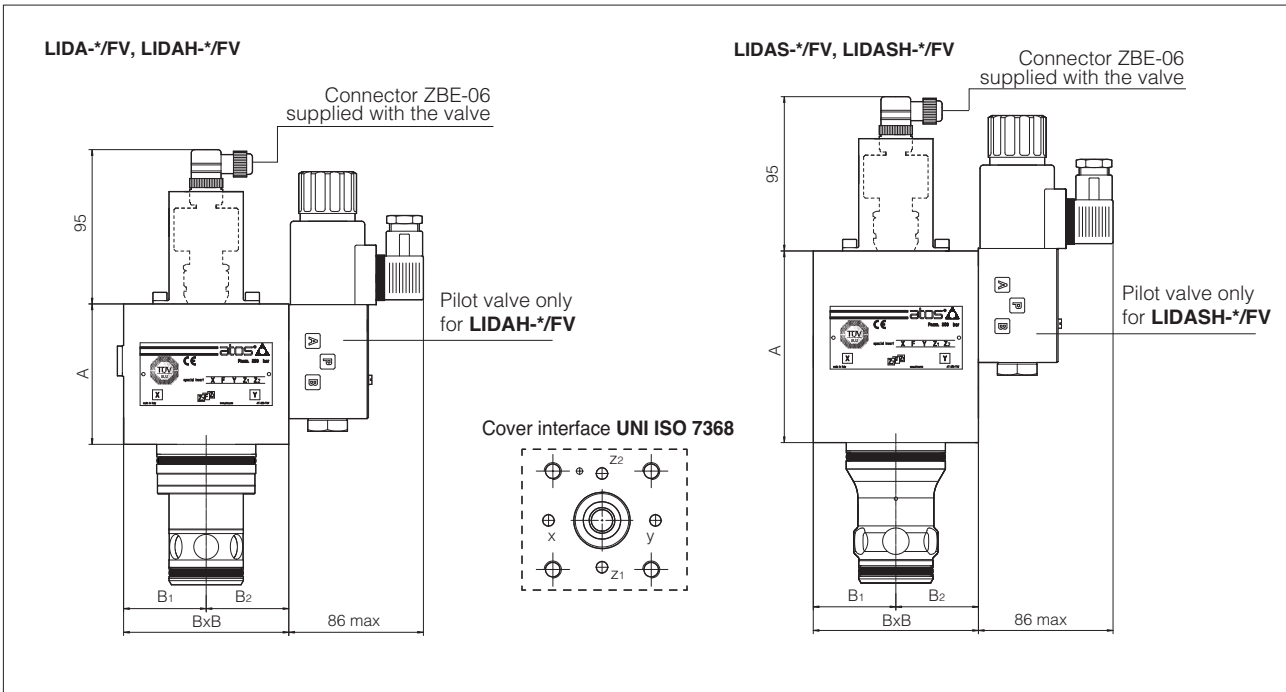

Note: for cover interface and cavity dimensions ISO 7368, see table P006

Size	LIDA				LIDAH				LIDAS				LIDASH				Seal		Fastening bolts				Tightening torque (Nm)
	A	B	B ₁	B ₂	A	B	B ₁	B ₂	A	B	B ₁	B ₂	A	B	B ₁	B ₂	LIDA	OTHER	LIDA	LIDAH	LIDAS, LIDASH		
16	50	65x80	40.5	39.5	85	65x80	40.5	39.5	85	65	39.5	39.5	95	65x72	32.5	39.5	1 OR 108	4 OR 108	4 M8x50	4 M8x70	4 M8x80	35	
25	50	85	42.5	42.5	85	85	42.5	42.5	98	85	42.5	42.5	115	85	42.5	42.5	1 OR 108	4 OR 108	4 M12x55	4 M12x80	4 M12x95	125	
32	65	100	50	50	85	100	50	50	107	100	50	50	116	100	50	50	1 OR 2043	4 OR 2043	4 M16x70	4 M16x70	4 M16x105	300	
40	65	125	62.5	62.5	85	125	62.5	62.5	110	125	62.5	62.5	125	125	62.5	62.5	1 OR 2050	4 OR 2050	4 M20x80	4 M20x80	4 M20x70	600	
50	65	140	70	70	85	140	70	70	130	140	70	70	135	140	70	70	1 OR 2050	4 OR 2050	4 M20x80	4 M20x80	4 M20x80	600	