

GR72 - Dimensional drawings / Disegni dimensionali

GR72 SHAFT AND FLANGE TYPES AND DIMENSIONS / TIPI DI ALBERO E FLANGIA E DIMENSIONI

Group 4 pumps / Pompe gruppo 4

Type	Class	Flange & Shaft available types	Ports	Weight
GR72	2V	FSAED AC FSAED AT23	ME	30 Kg

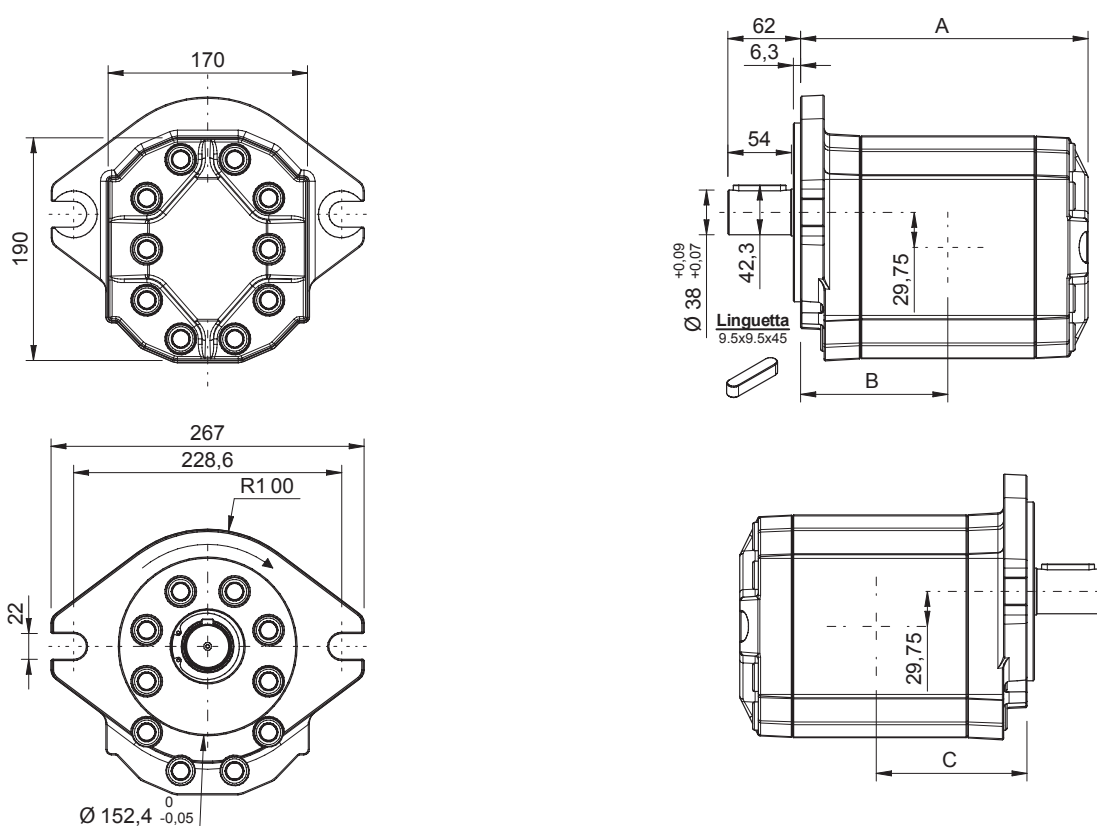

GR72 - TYPE / TIPO FSAED AC

Type Tipo	CC	L/min	Dimensions A Dimensioni A	Dimensions B Dimensioni B	Dimensions C Dimensioni C	Continuous Pressure Pressione continua	Intermittent Pressure Pressione intermittente (*)	Peak pressure Picco pressione (*)	Noise level Livello rumore
94	94,1	136	245	125,5	128,5	240	250	260	57
101	101,4	147	248	127	134	230	240	250	57
125	125,5	181	258	132	145	220	220	230	57
150	150,9	218	268,5	137,3	150,3	200	210	220	57
175	175	253	278,5	142,3	155,3	180	190	200	57
200	200,4	290	289	147,5	160,5	160	170	180	57

Max torque / Coppia max: 1000 Nm

* Intermittent: cycle 20 sec. ON & 3 sec. OFF - Peak: cycle 1 sec. ON & 3 sec OFF. Intermittente: ciclo 20 sec. ON & 3 sec. OFF - Picco: ciclo 1 sec. ON & 3 sec OFF

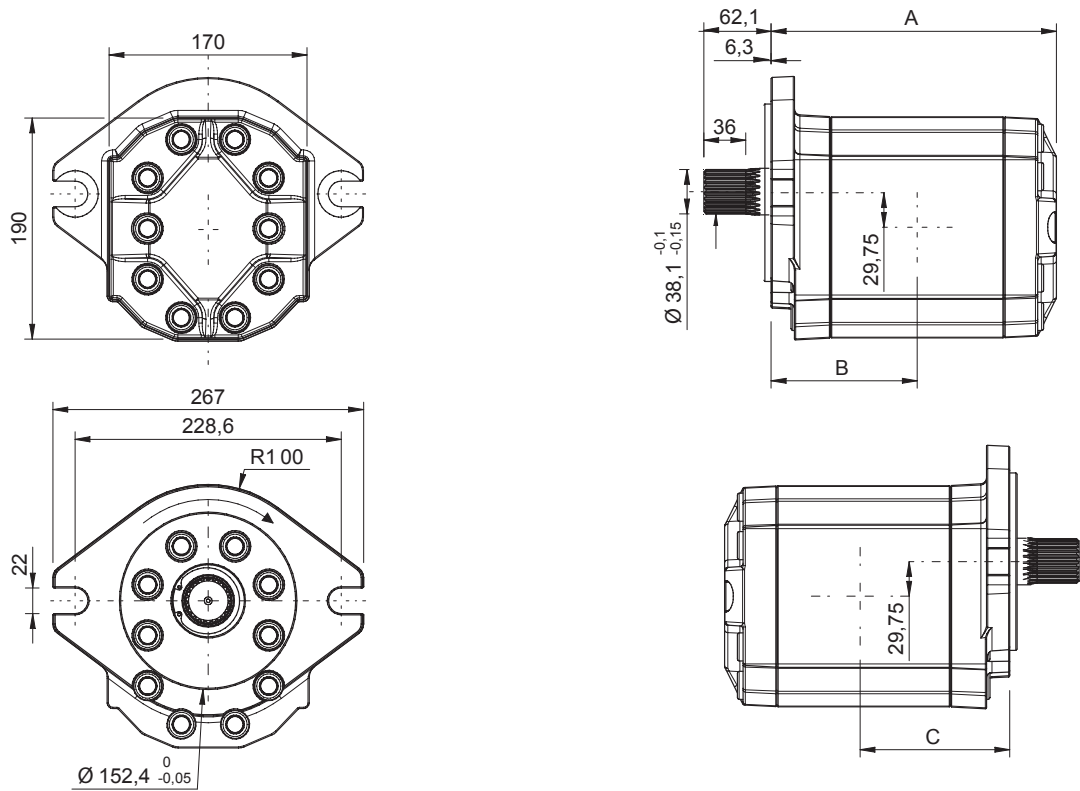

GR72 - TYPE / TIPO FSAED AT23

Type Tipo	CC	L/min	Dimensions A Dimensioni A	Dimensions B Dimensioni B	Dimensions C Dimensioni C	Continuous Pressure Pressione continua	Intermittent Pressure Pressione intermittente (*)	Peak pres- sure Picco pres- sione (*)	Noise level Livello rumore
94	94,1	136	245	125,5	128,5	240	250	260	57
101	101,4	147	248	127	134	230	240	250	57
125	125,5	181	258	132	145	220	220	230	57
150	150,9	218	268,5	137,3	150,3	200	210	220	57
175	175	253	278,5	142,3	155,3	180	190	200	57
200	200,4	290	289	147,5	160,5	160	170	180	57

Max torque / Coppia max: 1200 Nm

* Intermittent: cycle 20 sec. ON & 3 sec. OFF - Peak: cycle 1 sec. ON & 3 sec OFF. Intermittente: ciclo 20 sec. ON & 3 sec. OFF - Picco: ciclo 1 sec. ON & 3 sec OFF

GR72 INLET OUTLET PORTS / PORTE DI ASPIRAZIONE E MANDATA - Type ME / Tipo ME

