



S...N-N

Ucho

Ball joint ends

- NIE WYMAGA KONSERWACJI • MAINTENANCE FREE
- MATERIAŁ OBUDOWY: STAL NIERDZEWNA AISI 304 • HOUSING MATERIAL: STAINLESS STEEL AISI 316
- MATERIAŁ ŁOŻYSKA: ŁĄCZENIE STAL NIERDZEWNA AISI 420 + TKANINA PTFE • BEARING MATERIAL: STAINLESS STEEL AISI 420+ PTFE FABRIC

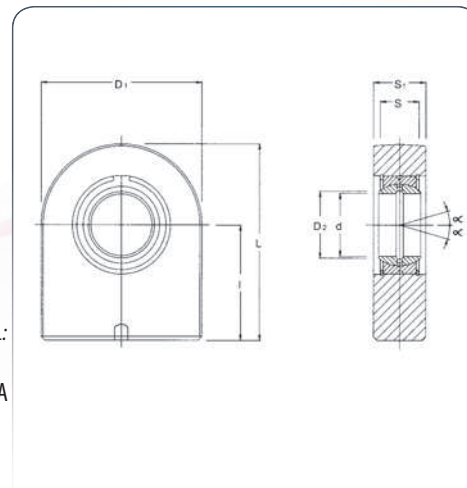

Kod Code	d	S	I	D1	D2	S1	L	Tolerancja Tolerances		Luz promieniowy Bearing radial clearance	Nośność Load Factor		Kąt oscylacji Angle Of Oscillation	Waga Weight
								d	S		Statyczna Static CO	Dynamiczna Dynamic C		
								mm	mm					
S 20N-UK-N	20	16	38	50	24,1	19	63	0÷0,01	0÷-0,12	0,03÷0,082	67	30	9°	0,325
S 25N-UK-N	25	20	45	55	29,3	23	72,5	0÷0,01	0÷-0,12	0,037÷0,1	69,5	48	7°	0,5
S 30N-UK-N	30	22	51	65	34,2	28	83,5	0÷0,01	0÷-0,12	0,037÷0,1	118	62	6°	0,825
S 35N-UK-N	35	25	61	83	39,7	30	102,5	0÷0,012	0÷-0,12	0,037÷0,1	196	80	6°	1,475
S 40N-UK-N	40	28	69	101	45	35	119	0÷0,012	0÷-0,12	0,043÷0,12	300	100	7°	2,48
S 45N-UK-N	45	32	77	111	50,7	40	132	0÷-0,12	0÷-0,12	0,043÷0,12	380	127	7°	3,45
S 50N-UK-N	50	35	88	123	56	40	149,5	0÷-0,12	0÷-0,12	0,043÷0,12	440	156	6°	4,45