

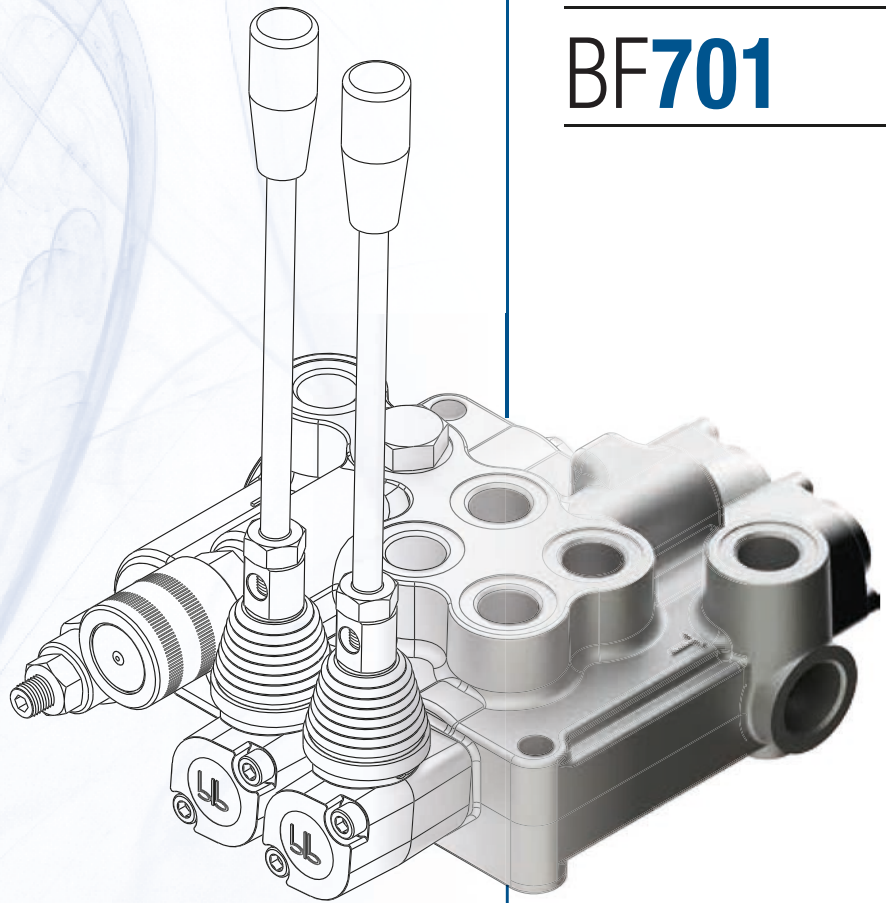

**BM70**

**BM100**

**BF701**



**UPGRADE YOUR HYDRAULIC CONTROL**

## PRESENTATION

---

This catalogue contains the information needed for the selection and proper use of the hydraulic directional control valve BM70, BM100 and BF701 Series.

The design, manufacturing process and controls meet the relevant EU standards and directives on safety and quality. BM70, BM100 and BF701 directional control valve are produced by BLB Srl.

## WARNINGS

---

Before using BM70, BM100 and BF701 directional control valves carefully read this catalogue in all its parts. The applications of these products must comply with the information contained in it.

*Contact our BLB technical department in all cases in which the correspondence of the product to **the application requirements is uncertain.***

The proper operation of BM70, BM100 and BF701, is strictly subjected to the compliance with the directions, instructions, and specifications stated in this catalogue.

Therefore, operations and uses that require actions other than those herein described and/or approved in advance by BLB srl., may give rise to defects or failures that exempt BLB from all liabilities. To ensure the specifications given in the catalogue, make sure that the maximum parameters are not exceeded during operation.

BLB is not liable for any damage that may be caused to persons or property resulting from misuse of the product. Therefore, consult with the utmost attention the chapter **instructions**.

The catalogue shows the most common configurations. For more detailed information or special requests herein not provided, please contact BLB Srl Sales Department.

Specifications, drawings and descriptions contained in this catalogue refer to the standard product at the date of publication of this catalogue. Blb, in a perspective of continuous product improvement, reserves the right to make changes at any time and without the obligation of any prior notification.

First Edition January 2016  
C-BM70, BM100 and BF701

### **BLB S.r.l.**

Via Natta 1,  
36040 Brendola (VI)  
Italy

**T.** +39 0444 401141

**W.** [www.blbhydraulic.com](http://www.blbhydraulic.com)

# APPLICATIONS



Waste compactor



Log splitter



Compactor

**BM70**

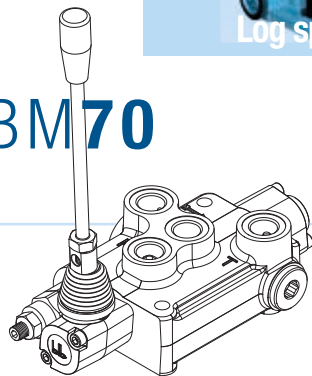

Boat Winch



Sewage Cleaning

**BF701**

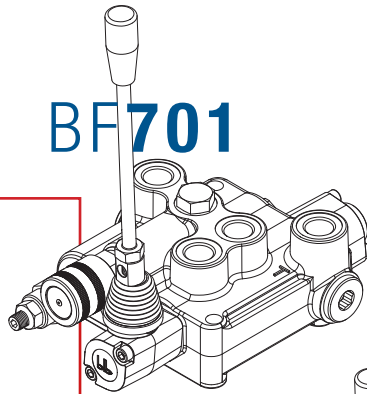

Fork Lift



Sewage Cleaning

**BM100**

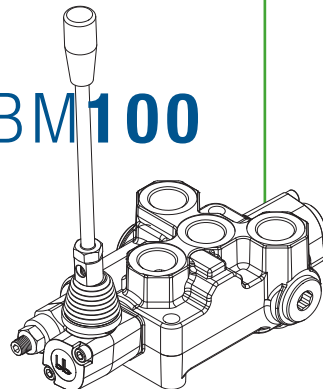

Hedge Mowers

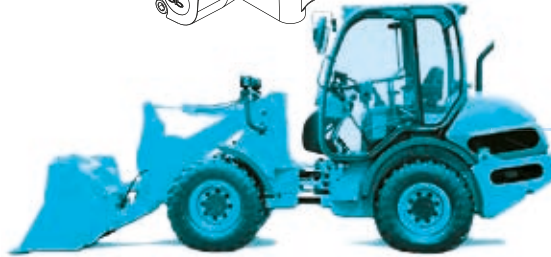
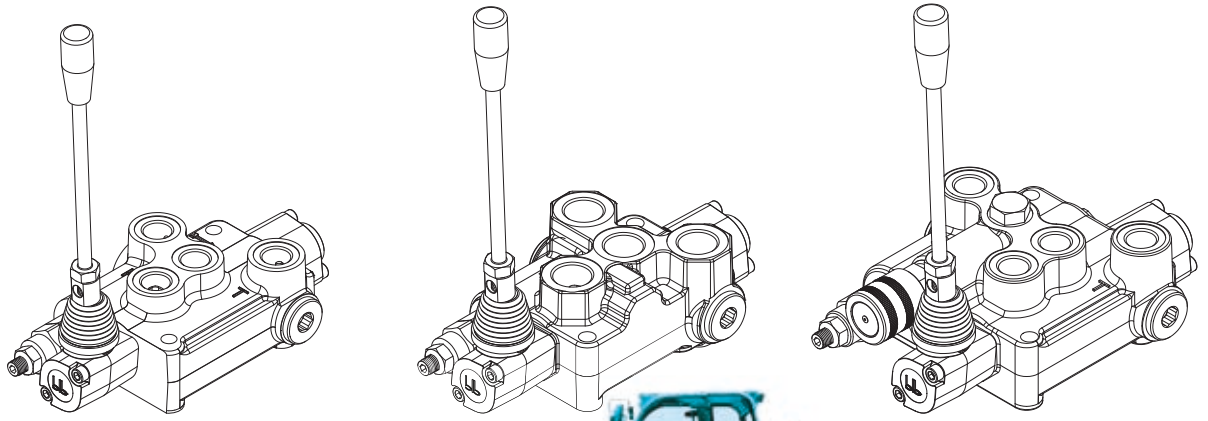

# SUMMARY

---

<b>GENERAL INFORMATION BM70 / BM100</b>	<b>6</b>
<b>DESIGNATION BM70 / BM100</b>	<b>7</b>
<b>TECHNICAL SPECIFICATIONS BM70</b>	<b>8</b>
<b>TECHNICAL SPECIFICATIONS BM100</b>	<b>9</b>
<b>BM70 AUTOSPEED</b>	<b>10</b>
<b>BM70/100 WITH ROTARY CONTROL</b>	<b>11</b>
<b>GENERAL INFORMATION BF701</b>	<b>12</b>
<b>DESIGNATION BF701</b>	<b>13</b>
<b>TECHNICAL SPECIFICATIONS BF701</b>	<b>14</b>
<b>SPARE PARTS:</b>	<b>15</b>
RELIEF VALVES AND ACCESSORIES	15
ACTUATORS	18
SPOOLS	22
SPOOL CONTROLS	26
PLUGS	32
<b>INSTRUCTIONS</b>	<b>34</b>

# GENERAL INFORMATION

## BM70 / BM100

This booklet is meant to be a technical deepening on directional control valves of the BM70 and BM100 series. These monoblock valves are characterized by a single body having following features:

- **Sound construction.**
- **Compact size.**
- **Reduced weight.**

The absence of tie rods and intermediate seals allow monoblock valves to provide:

- **Improved dependability.**
- **Sturdy valves body for fewer leak points.**
- **Lower maintenance.**

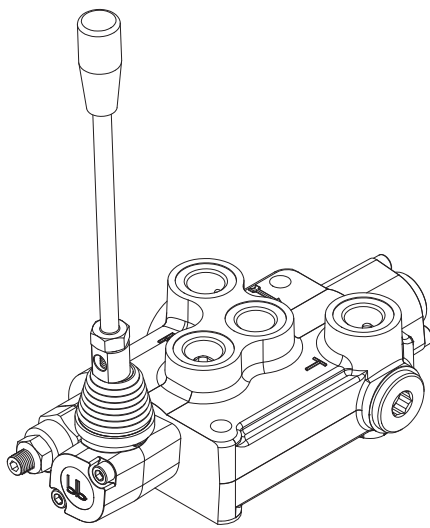
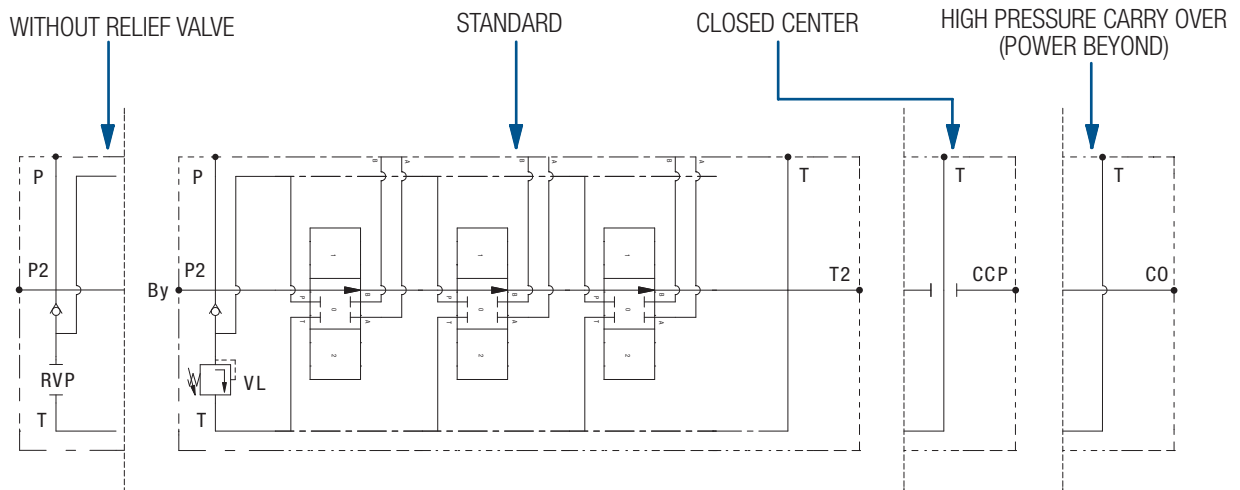

BM70

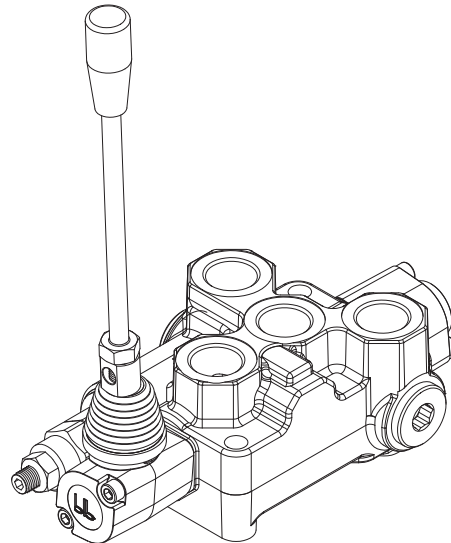

BM100

# DESIGNATION

BM70 / BM100

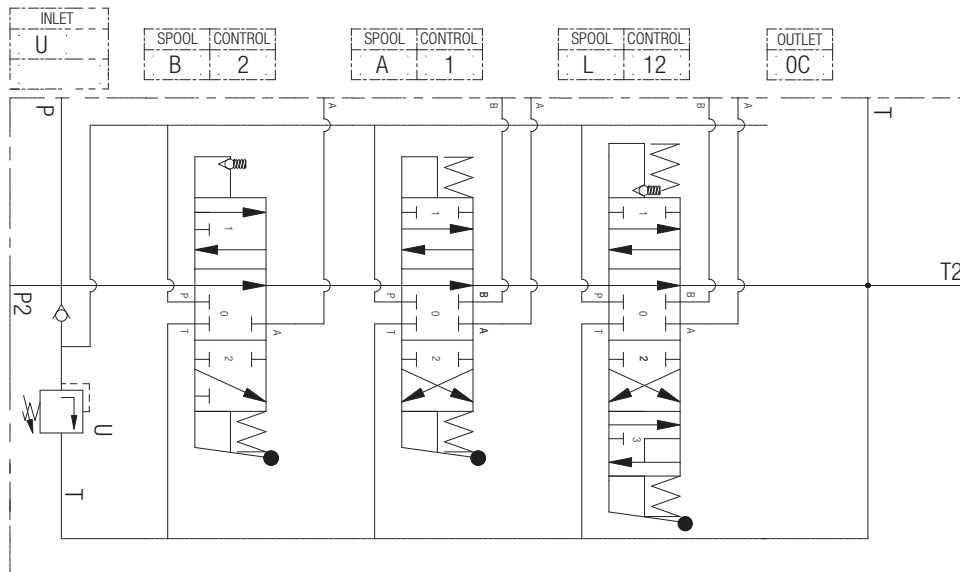
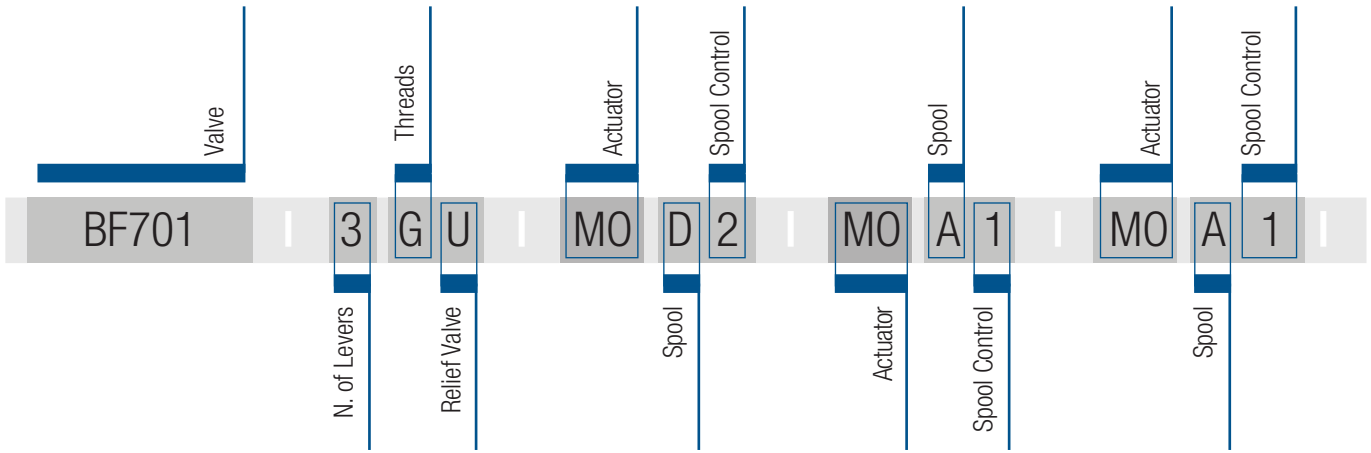

# TECHNICAL SPECIFICATIONS

## BM70

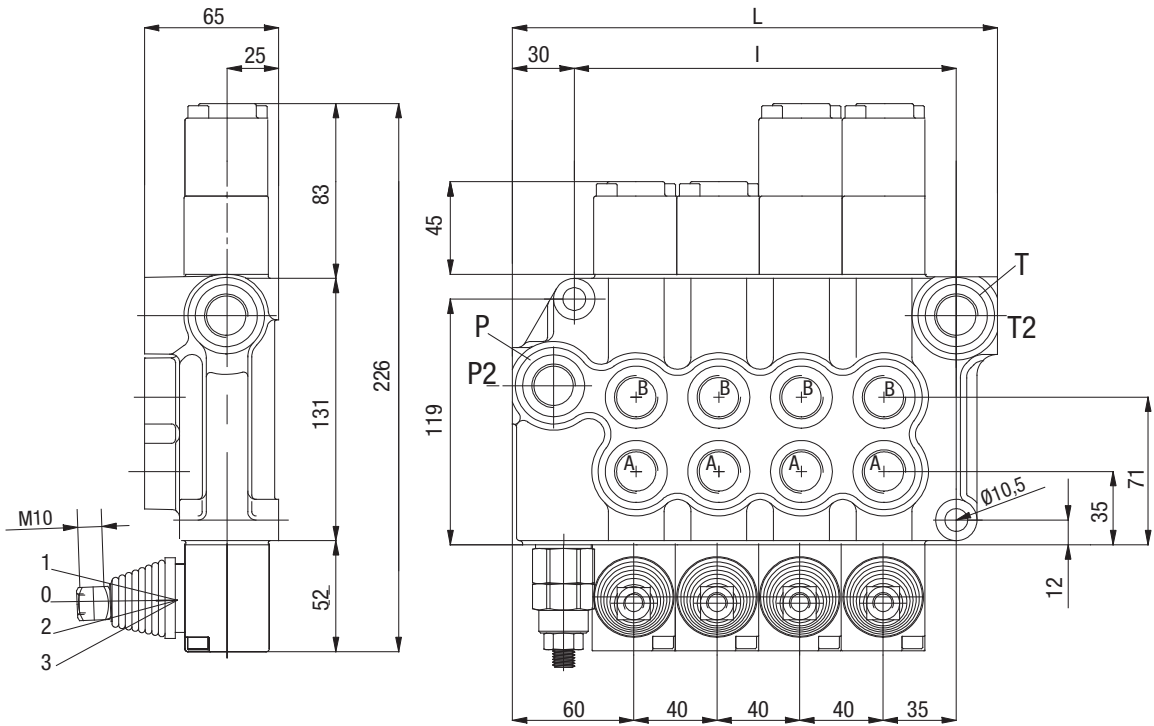

### TECHNICAL CHARACTERISTICS

NOMINAL FLOW	70 l/min	18.5 GPM
MAX FLOW	80 l/min	21,5 GPM
MAX FLOW - Electrical control	60 l/min	16 GPM
NOMINAL PRESSURE	250 bar	3600 PSI
MAX PRESSURE ON PORTS	320 bar	4700 PSI
MAX PRESSURE ON PORTS - Electrical control	160 bar	2300 PSI
MAX PRESSURE ON TANK-LINE	80 bar	1100 PSI

### STANDARD THREADS

	A - B	P	T	P2	T2
G (BSP)	1/2"	1/2"	1/2"	3/4"	3/4"
F (UNF)	7/8" -14	7/8" -14	7/8" -14	1.1/16" -12	1.1/16" -12

### INTERNAL OIL LEAKAGE

A - B → T	4 ÷ 8 cc/min
-----------	--------------

### TESTING CONDITIONS

PRESSURE	100 bar
OIL TEMPERATURE	40 °C
OIL VISCOSITY	32 mm <sup>2</sup> /s

### STANDARD THREADS

NUMBER OF SECTIONS	L		I		kg	lb
	(mm)	(inch)	(mm)	(inch)		
BM70/1	115	4.52	65	2.55	4.5	9.1
BM70/2	155	6.1	105	4.13	7.4	16.5
BM70/3	195	7.67	145	5.7	9.9	21.1
BM70/4	235	9.25	185	7.28	11.4	25.2
BM70/5	275	10.8	225	8.85	13.6	29.2
BM70/6	315	12.4	265	10.43	16	35.4

### PRESSURE DROP

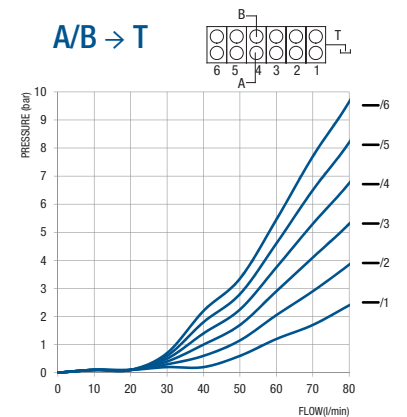
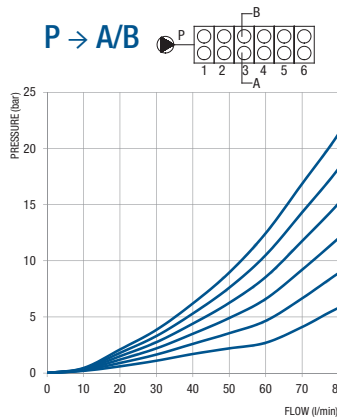
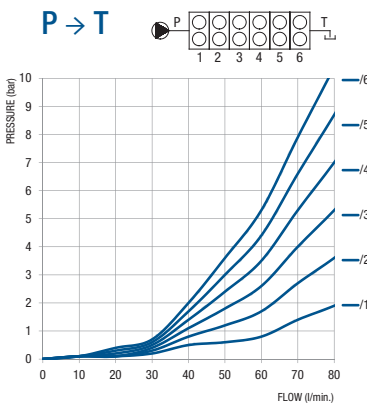



# TECHNICAL SPECIFICATIONS

## BM100

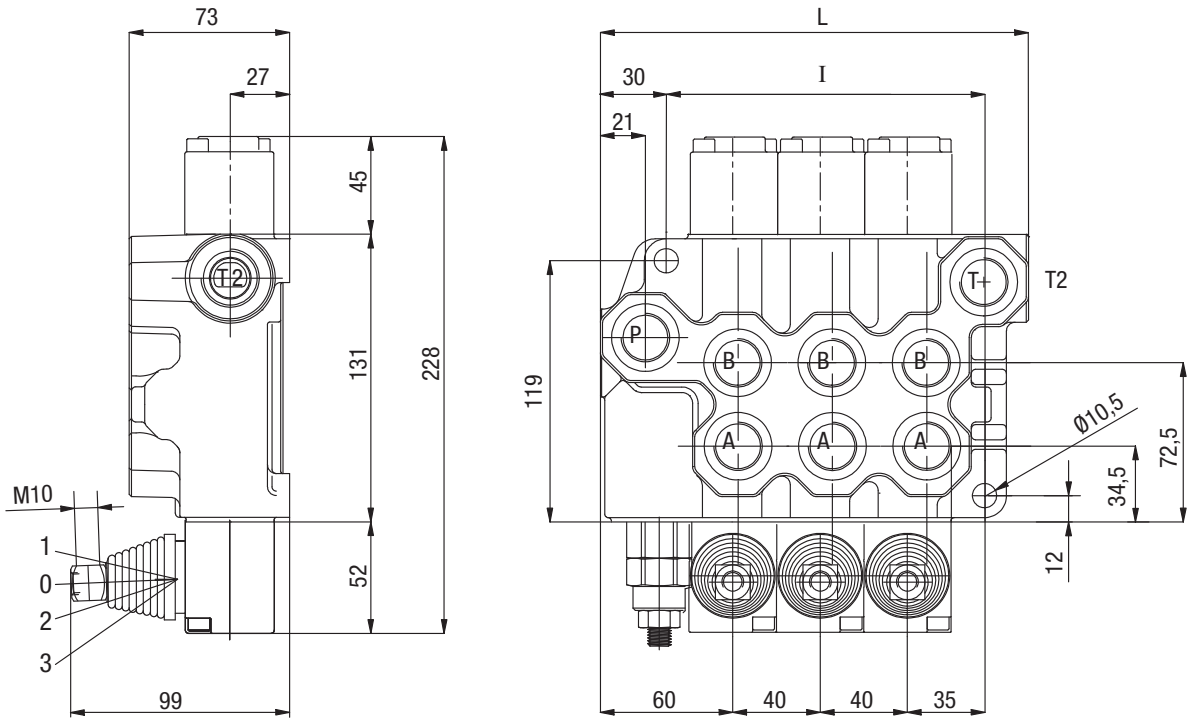

### TECHNICAL CHARACTERISTICS

NOMINAL FLOW	90 l/min	24 GPM
MAX FLOW	100 l/min	26 GPM
MAX FLOW - Electrical control	60 l/min	26 GPM
NOMINAL PRESSURE	250 bar	3600 PSI
MAX PRESSURE ON PORTS	320 bar	4700 PSI
MAX PRESSURE ON PORTS - Electrical control	160 bar	2300 PSI
MAX PRESSURE ON TANK-LINE	80 bar	1100 PSI

### STANDARD THREADS

	A - B	P	T	P2	T2
G (BSP)	3/4"	3/4"	3/4"	3/4"	3/4"
F (UNF)	1.1/16"-12	1.1/16"-12	1.1/16"-12	1.1/16"-12	1.1/16"-12

### INTERNAL OIL LEAKAGE

<b>A - B → T</b>	4 ÷ 8 cc/min
------------------	--------------

### TESTING CONDITIONS

PRESSURE	100 bar
OIL TEMPERATURE	40 °C
OIL VISCOSITY	32 mm <sup>2</sup> /s

### STANDARD THREADS

NUMBER OF SECTIONS	L (mm)	L (inch)	I (mm)	I (inch)	kg	lb
BM100/1	115	4.52	65	2.55	4.5	9.1
BM100/2	155	6.1	105	4.13	7.4	16.5
BM100/3	195	7.67	145	5.7	9.9	21.1

### PRESSURE DROP

**P → T**

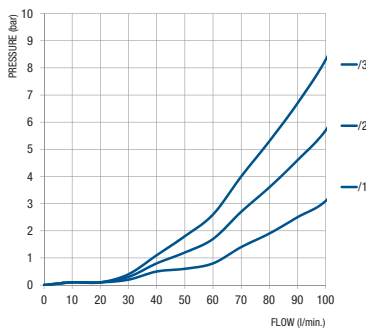
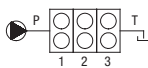

**P → A/B**

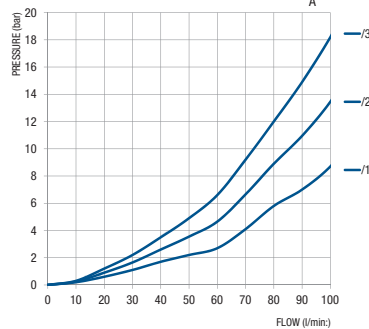
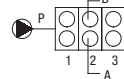

**A/B → T**

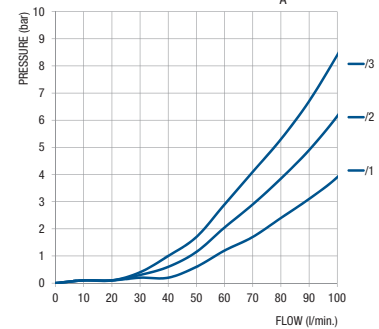
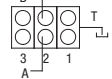

# BM70 AUTOSPEED

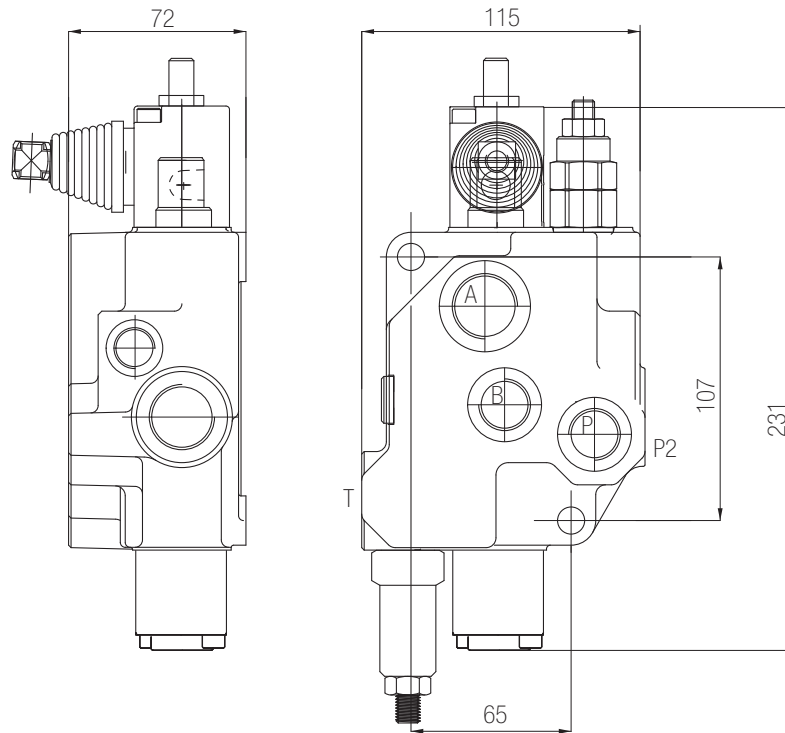

Special valve dedicated to log-splitter applications, both horizontal and vertical. Main features are the fast approach to the log (with max flow and pressure <70 bar) and the following passage to the log-cutting mode (with low flow and max pressure).

Available with or without the **kickout feature** (automatic return from back position to center).

Max pump flow: **55/60 l/min – 14.4/15.8 GPM**

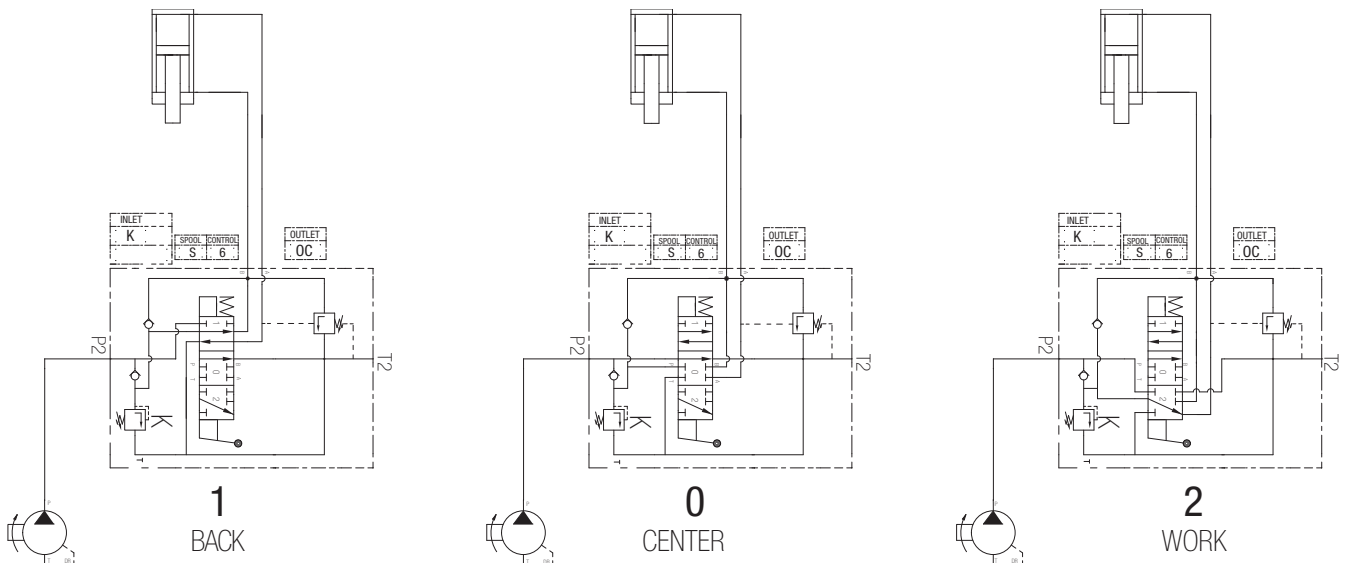

# ROTARY CONTROL

## BM70 / BM100

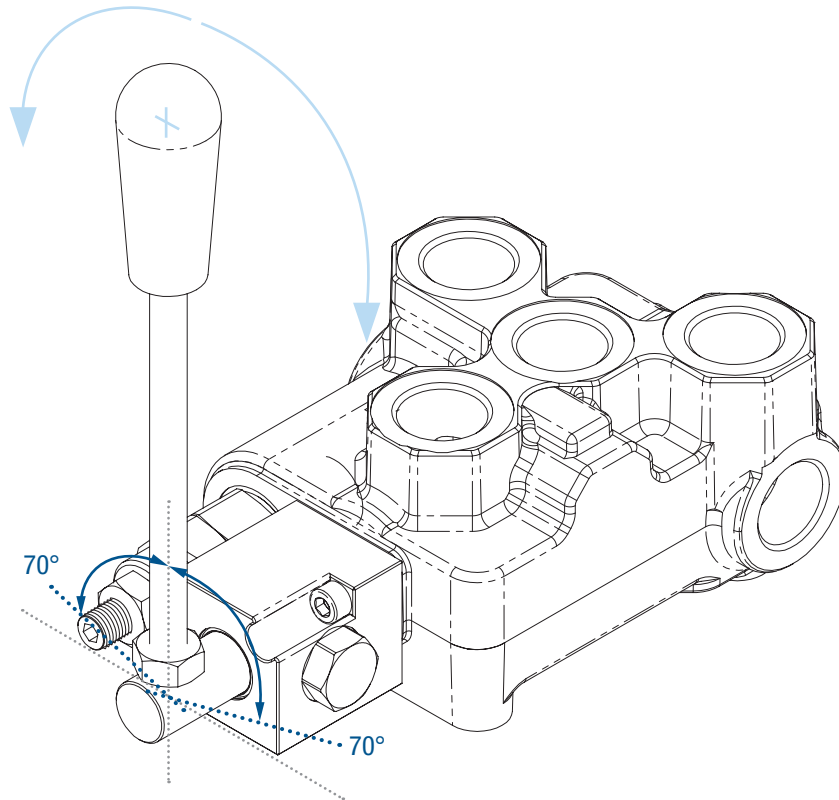

Mainly used in marine equipments to control the speed of the fishing winches motors, rotary control is available on BM70 and BM100 series.

The valve is operated **turning the lever into a range of 70°+70°**. The spool is detented (frictioned) in every position inside the overmentioned range.

Valves are protected against marine corrosion with the **Black Dacromet** treatment and many components are realized in stainless steel.

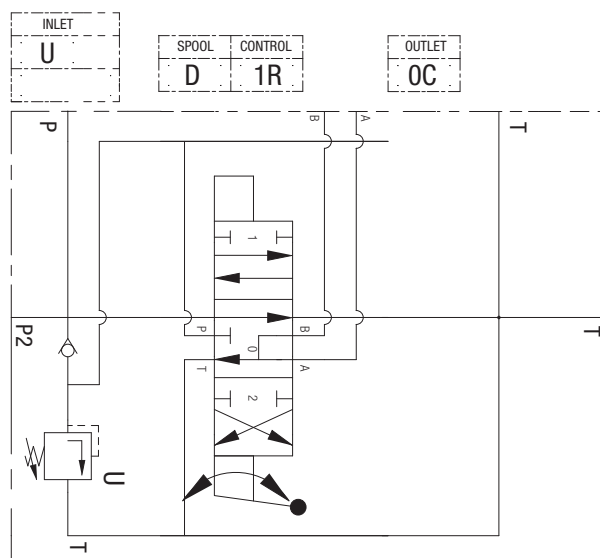

# GENERAL INFORMATION

## BF701

**BF** monoblock valves series derives from **BM** series and differs from it for having integrated in the inlet a **pressure compensated flow control either 3/ways priority (RFP) or 2/ways (RFS)**.

With **RFP** flow control, the exceeding flow is recuperated into the system and allows the simultaneous use of two spools, the first fed by the priority flow (**PF**) and the second fed by the exceeding flow (**EF**).

With **RFS** flow control, the exceeding flow goes to tank.

Very important characteristic is that the **flow control only works when a priority element is actuated**; if no priority element is operated, oil goes to tank eliminating loss of flow and unnecessary heating.

In RFP version, non-priority sections get the whole valve flow when they are individually operated or just the exceeding flow when a priority section is operated. One or more priority elements are available.

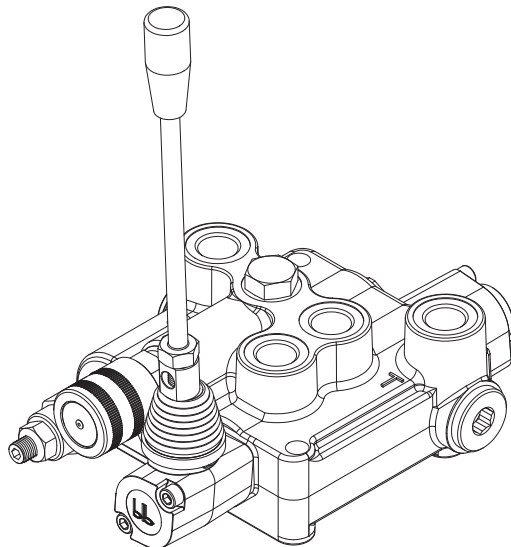
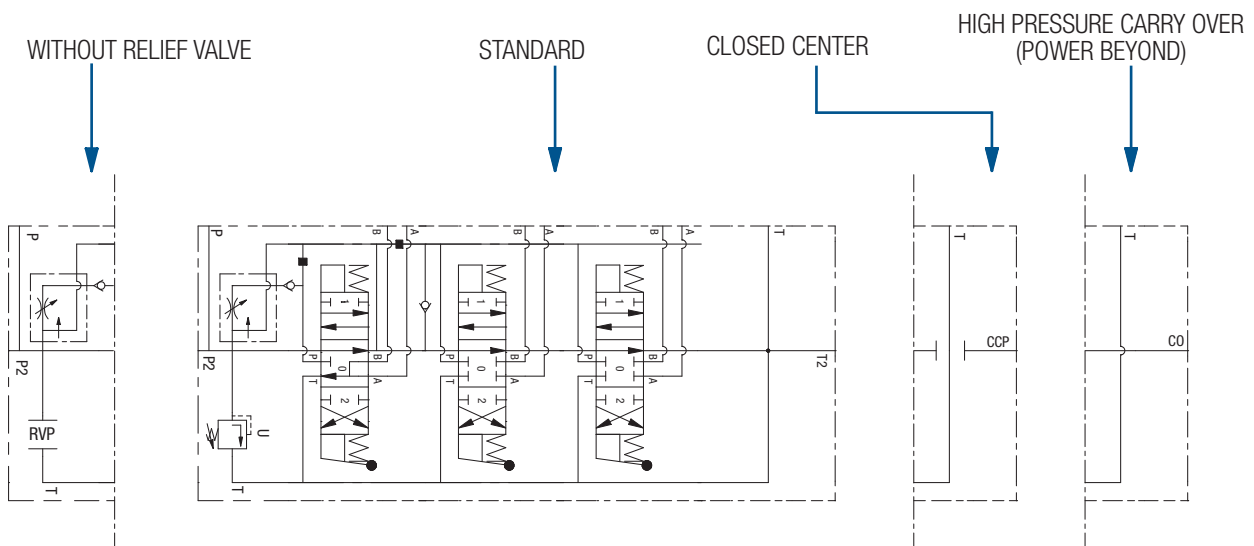

# DESIGNATION

## BF701

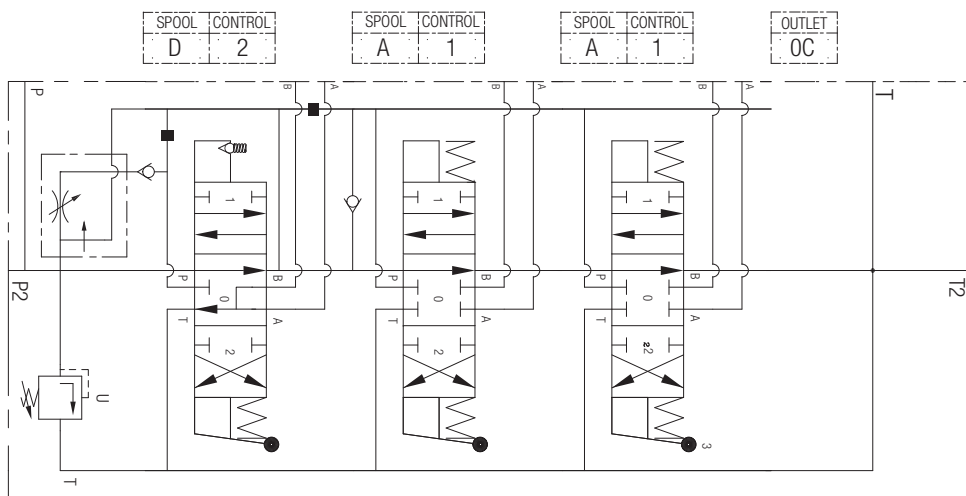
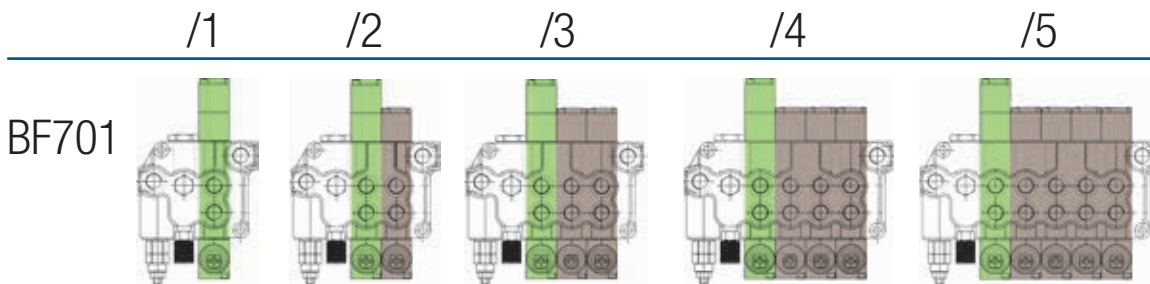
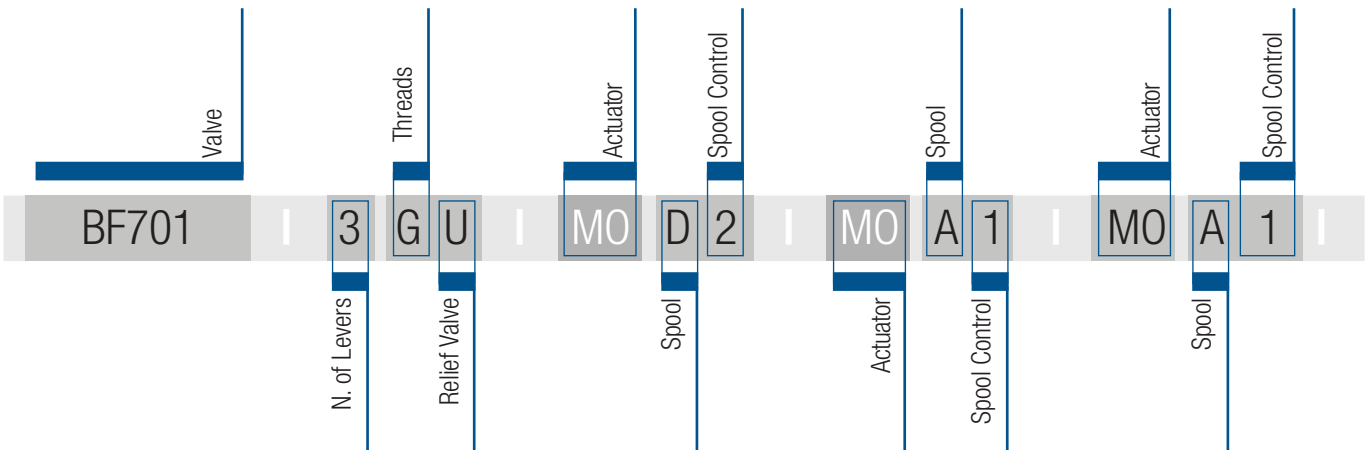

# TECHNICAL SPECIFICATIONS

## BF701

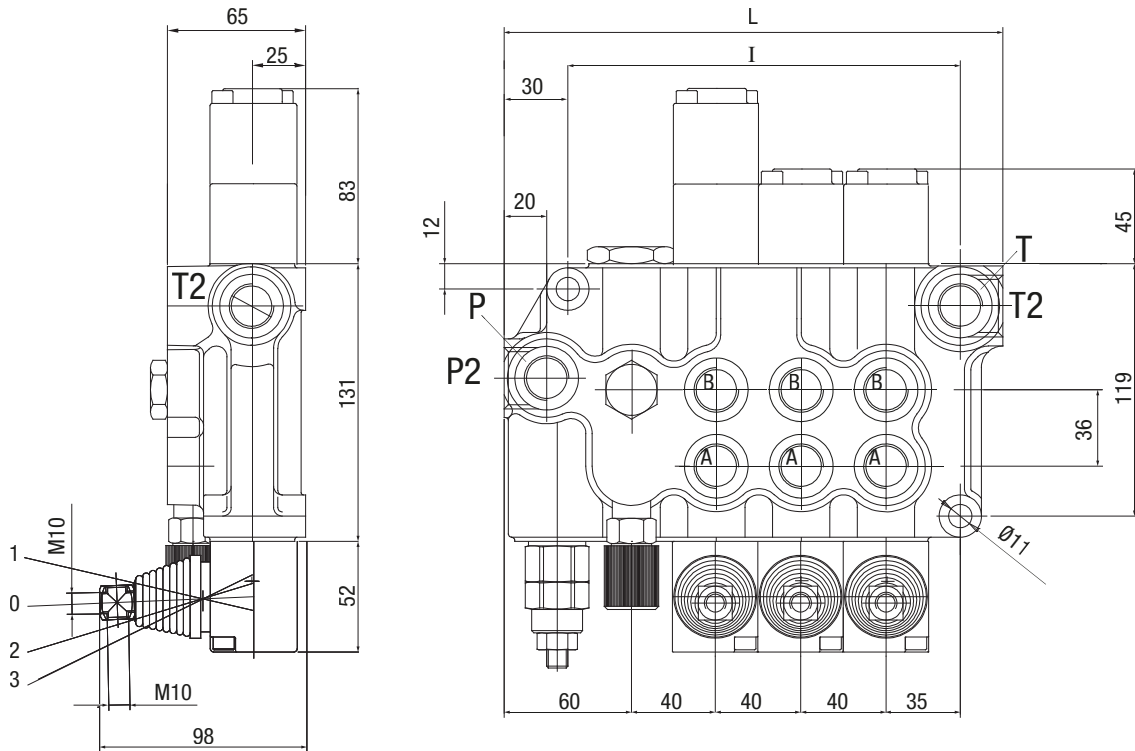

### TECHNICAL CHARACTERISTICS

NOMINAL FLOW	70 l/min	18.5 GPM
MAX FLOW	80 l/min	21,5 GPM
NOMINAL PRESSURE	250 bar	3600 PSI
MAX PRESSURE ON PORTS	320 bar	4700 PSI
MAX PRESSURE ON TANK-LINE	80 bar	1100 PSI

### INTERNAL OIL LEAKAGE

A - B → T	4 ÷ 8 cc/min
-----------	--------------

### TESTING CONDITIONS

PRESSURE	100 bar
OIL TEMPERATURE	40 °C
OIL VISCOSITY	32 mm <sup>2</sup> /s

### STANDARD THREADS

	A - B	P	T	P2	T2
G (BSP)	1/2"	1/2"	1/2"	3/4"	3/4"
F (UNF)	7/8"-14	7/8"-14	7/8"-14	1.1/16"-12	1.1/16"-12

### STANDARD THREADS

NUMBER OF SECTIONS	L		l		kg	lb
	(mm)	(inch)	(mm)	(inch)		
BF701/1	155	6.1	105	4.13	6.6	14.8
BF701/2	195	7.67	145	5.7	9	19.1
BF701/3	235	9.25	185	7.28	11.2	24.1
BF701/4	275	10.8	225	8.85	13.5	25.1
BF701/5	315	12.4	265	10.43	15.7	35

### PRESSURE DROP

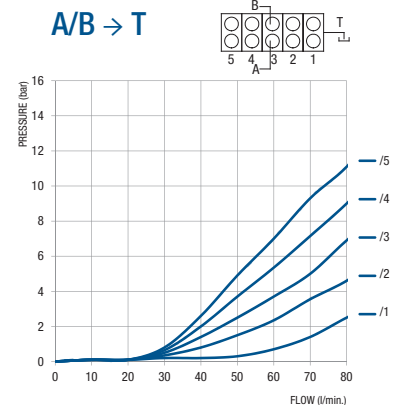
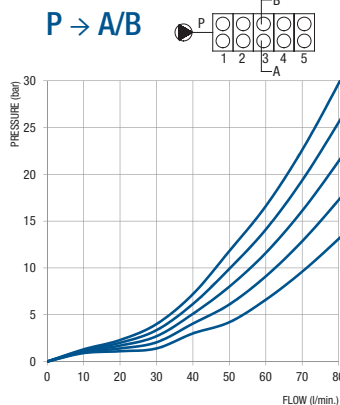
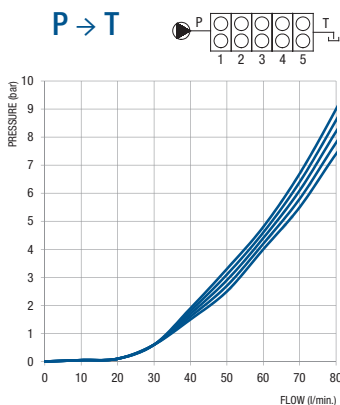

# SPARE PARTS

## Relief valves and accessories

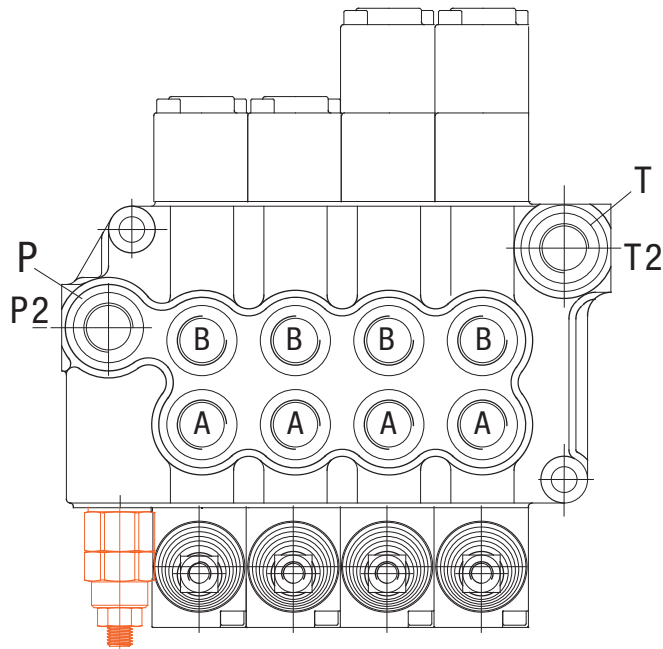

### RELIEF VALVE VL80

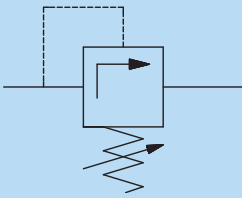

X  
U  
K



XB  
UB  
KB



VALVE X - Code 803018

VALVE U - Code 803064

VALVE K - Code 803013

VALVE XB - Code 803110

VALVE UB - Code 803076

VALVE KB - Code 803105

! - Standard setting is based on a **pre-set flow of 14 l/min.**

**X:** Pressure Range 30 ÷ 90 bar - STANDARD SETTING 70 bar

**U:** Pressure Range 80 ÷ 230 bar - STANDARD SETTING 140 bar

**K:** Pressure Range 150 ÷ 300 bar - STANDARD SETTING 180 bar

**B:** Prearranged for lock kit

### PRESSURE RANGE VL80

SPRING X

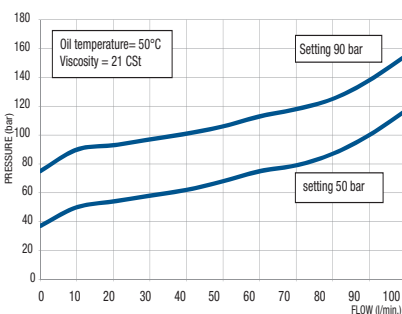

SPRING U

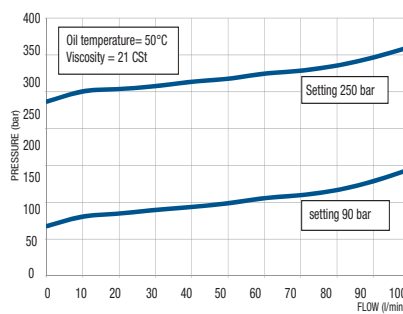

SPRING K

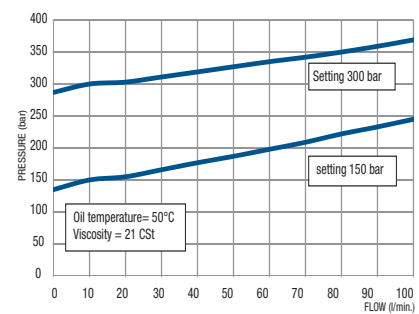

# SPARE PARTS

## PB - RELIEF VALVE LOCK KIT

Code 560945



Applied to VL\_B prevents users alteration of the prearranged relief valve setting.

## RVP - RELIEF VALVE PLUG

Code 832012



Replaces VL in closed center systems (i.e. John Deere tractors), in circuits where an in-line relief valve is provided or in case of two valves connected downstream by means of a carry over (power beyond) plug.

## VNR - LOAD CHECK VALVE KIT (BM70 / BM100)

Code 560274



Every BLB valve is provided with a load check valve VNR; it prevents the cylinder fall when a spool is actuated and the backflow from ports to inlet.



# SPARE PARTS

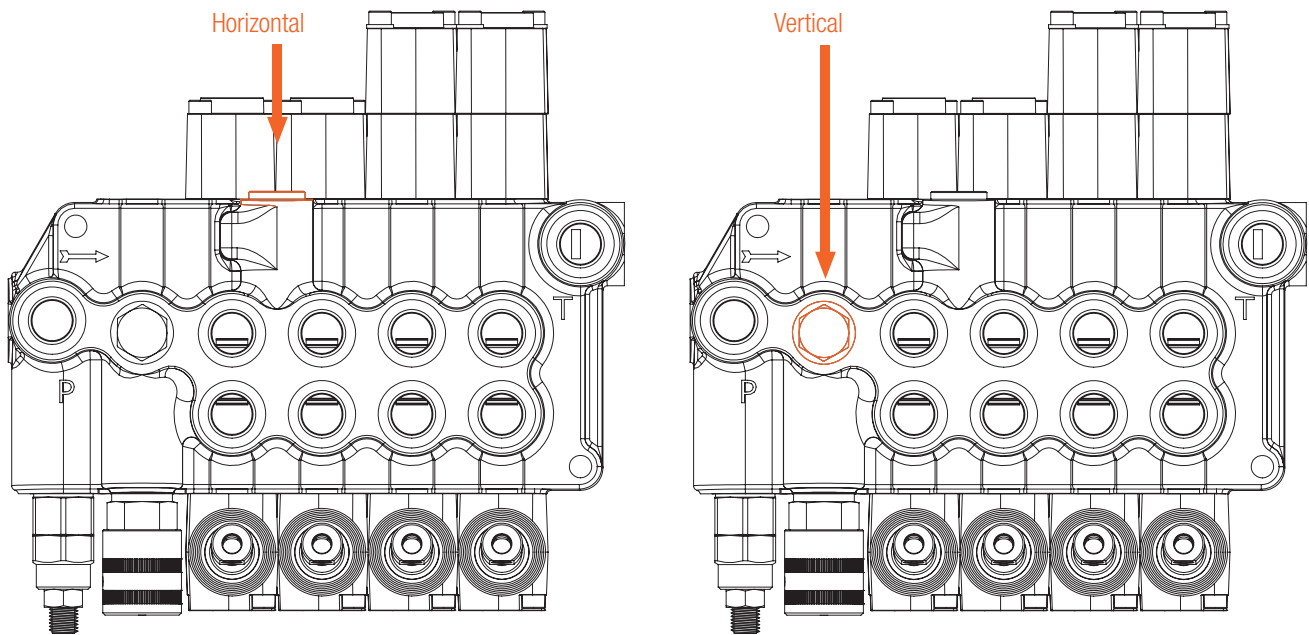

**VNR - LOAD CHECK VALVE KIT - Horizontal (BF701)**

**Code 560239**



Every BLB valve is provided with a load check valve VNR; it prevents the cylinder fall when a spool is actuated and the backflow from ports to inlet.

**VNR - LOAD CHECK VALVE KIT - Vertical (BF701)**

**Code 560241**



Every BLB valve is provided with a load check valve VNR; it prevents the cylinder fall when a spool is actuated and the backflow from ports to inlet.

# SPARE PARTS

## Actuators

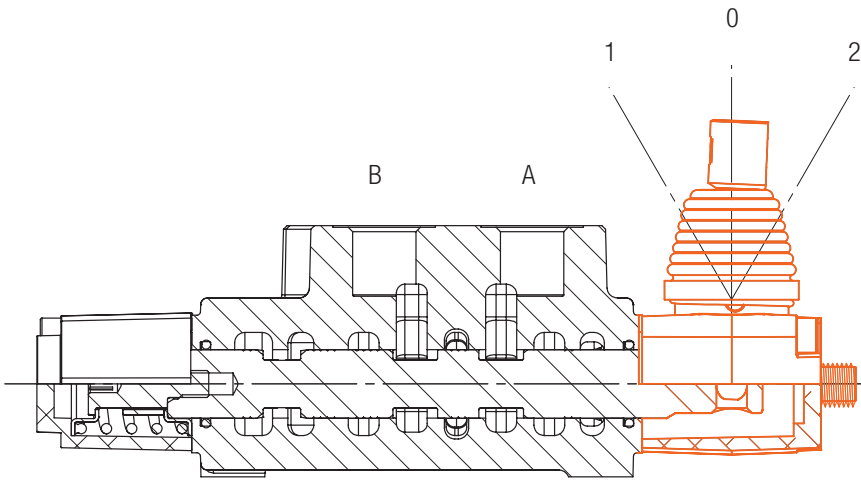

The actuator orientation is "A" if not differently requested

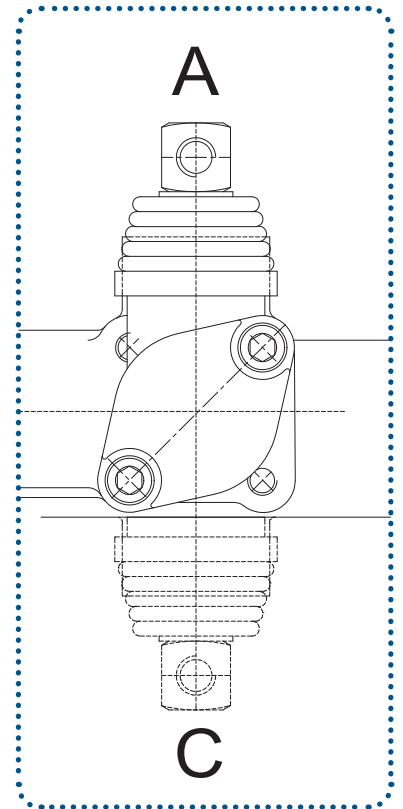

### MO - MANUAL LEVER CONTROL

Code 801014



Standard manual control with lever. Possibility to assembly the lever in vertical or horizontal position. Possibility to assembly the entire manual control in position A(90°) or B(180°).

### MW - MANUAL WITHOUT LEVER

Code 801116



Manual control as 801014 but the lever is not included.

### MC - MANUAL WITH CAM

Code 801010



Manual control as 801014 with the addition of a cam.

# SPARE PARTS

## DO - CAM

Code 801044



Cam actuator.

## HO - HYDRAULIC

Code 801246 - Single  
Code 561068 - Double



Hydraulic actuator for remote control.

## MX - SAFETY LEVER

Code 801262



The lever can be actuated only after the mechanical security system is released. It can be combined with other actuators in other sections.

## MR - MANUAL ROTARY LEVER (BM70 / BM100 ROTATIVO)

Code 801301

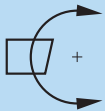

It allows the spool positioning in all the positions within the minimum and the maximum stroke. The lever has to be rotated around the spool axis. See page 31 for the spool control features (8DN).

## JS1 - MEHCANICAL JOYSTICK

Code JS1 - 801291

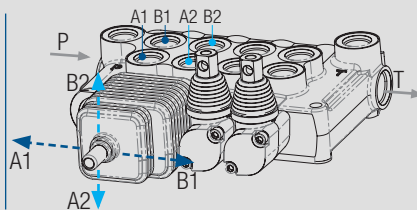

Operates two spools with one lever handle. Two spools can be operated independently or simultaneously, depending on the movement of the handle. Joystick requires to be assembled with spools AS, BS, DS.

## JS2 - MEHCANICAL JOYSTICK

Code JS2 - 801292

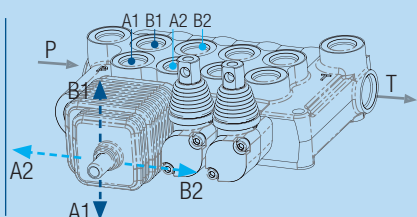

Operates two spools with one lever handle. Two spools can be operated independently or simultaneously, depending on the movement of the handle. Joystick requires to be assembled with spools AS, BS, DS.

# SPARE PARTS

## FO - MODULAR SINGLE LEVER

Code 801329



Modular single lever for cable remote control to be assembled with push-pull cables.

## FA - MODULAR SINGLE LEVER WITH ANTIREVERSE LOCK

Code 801332 (R)

Code 801336 (L)



Modular single lever with antireverse lock. Allows the operation of the lever only when the lock system is released.

## FJ1 - MECHANICAL JOYSTICK FOR FLEXIBLE CABLES

Code FJ1 - 801297

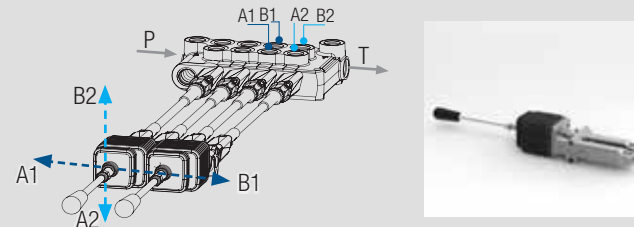

Operates 2 spools with one handle, through flexible cables. Spools can be operated independently or simultaneously, depending on the movement of the handle.

## FJ2 - MECHANICAL JOYSTICK FOR FLEXIBLE CABLES

Code FJ2 - 801298

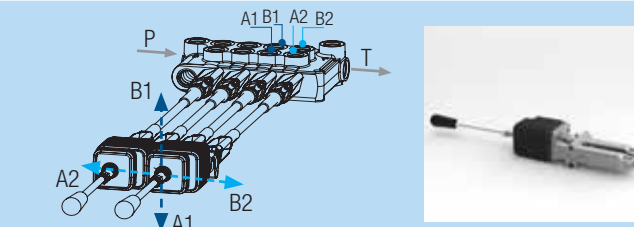

Operates 2 spools with one handle, through flexible cables. Spools can be operated independently or simultaneously, depending on the movement of the handle.

## FL - CABLE ADAPTER

Code 801331



Cable adapter for cable control. It allows the assembly of cable on the valve on the lever side.

## CA... - CABLE

Code

L [mt]



023038	CA 0.5
023087	CA 1.0
023088	CA 1.5
023089	CA 2.0
023090	CA 2.5
023091	CA 3.0
023092	CA 3.5
023093	CA 4.0

# SPARE PARTS

## EO 12V - ELECTRIC OPERATOR

Code 801519



The electric remote control is used when the directional control valve has to be placed away from the operator.  
Electric source required.

## EO 24V - ELECTRIC OPERATOR

Code 801520

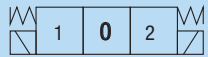

The electric remote control is used when the directional control valve has to be placed away from the operator.  
Electric source required.

# SPARE PARTS

## Spools

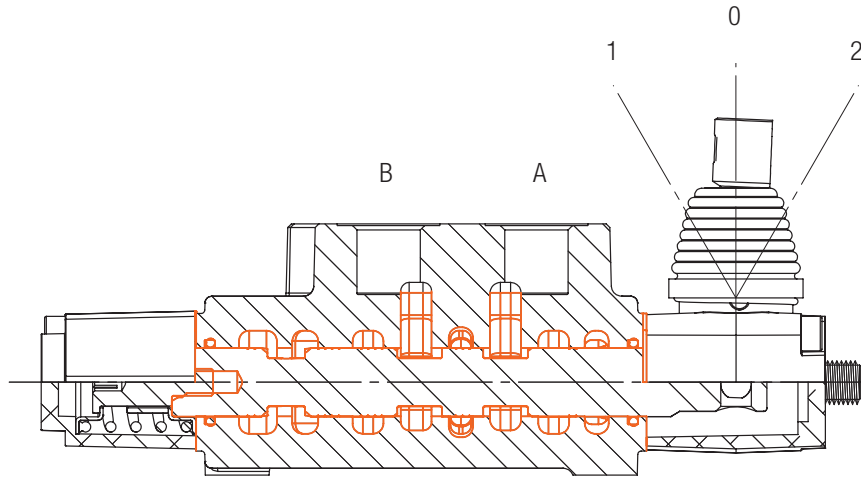

A/B = Ports  
 By = Bypass  
 P = Pressure  
 T = Tank

### SPOOL A | 4-WAY / 3-POSITION SPOOL

Code 560381

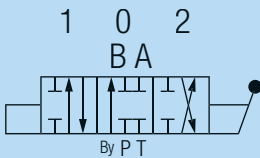

Provides control of double-acting cylinders or bi-directional hydraulic motors. In position 0 work ports are blocked.

### SPOOL AS | 4-WAY / 3-POSITION SPOOL

Code 560852

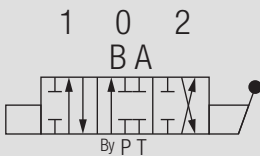

Same features as spool A but with threaded spool end. Required to assembly joysticks (JS), for valves with right inlet or for special applications.

### SPOOL SP | 4-WAY / 3-POSITION SPOOL

Code 560337

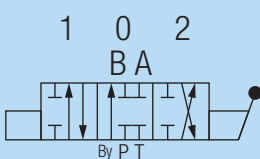

Same features as spool A but without meetering. Required for special applications (i.e. woodsplitter).

# SPARE PARTS

## SPOOL B | 3-WAY / 3-POSITION SPOOL

**Code 560378**

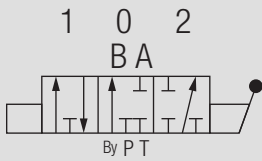

Provides control of single-acting cylinders or start and stop of uni-directional hydraulic motors. In position 0 work port A is blocked. B port is plugged.

## SPOOL BS | 3-WAY / 3-POSITION SPOOL

**Code 560126**

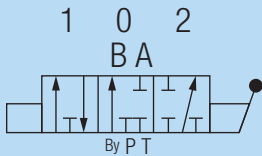

Same features as spool B but with threaded spool end. Required to assembly joysticks (JS), for valves with right inlet or for special applications.

## SPOOL C | 3-WAY / 3-POSITION SPOOL

**Code 560138**

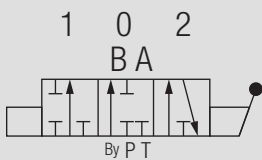

Provides control of single-acting cylinders or start and stop of uni-directional hydraulic motors. In position 0 work port B is blocked. A port is plugged.

## SPOOL D | 4-WAY / 3-POSITION SPOOL, OPEN CENTER (MOTOR SPOOL)

**Code 560379**

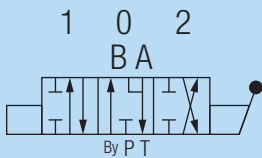

Provides control of double acting cylinders or bi-directional hydraulic motors. Allows a cylinder to float or a motor to wheel free when the spool is in position 0. Work ports are open to the tank when the spool is in position 0.

## SPOOL DS | 4-WAY / 3-POSITION SPOOL, OPEN CENTER (MOTOR SPOOL)

**Code 560128**

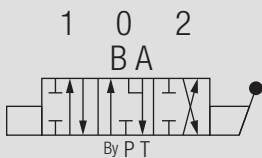

Same features as spool D but with threaded spool end. Required to assembly joysticks (JS), for valves with right inlet or for special applications.

## SPOOL L | 4-WAY / 4-POSITION, FLOATING SPOOL

**Code 560142**

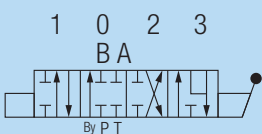

Same features as spool A with the addition of a fourth floating position. The floating position allows a cylinder to float or a motor to wheel free when the spool is in position 3. To be combined only with spool controls 12, 13. Special machining on the body is required.

# SPARE PARTS

## SPOOL S | 4-WAY / 3-POSITION, REGENERATIVE SPOOL (BM70 AUTOSPEED)

**Code 560874**

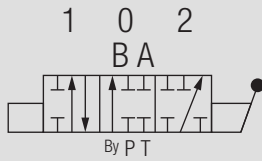

Regenerative spool for BM70 Autospeed.  
In position 2, with low pressure (up to 70 bar), it increases the cylinder opening speed; above 70 bar, it becomes a standard double acting circuit.

## SPOOL Z | 4-WAY / 4-POSITION, REGENERATIVE SPOOL

**Code 560146**

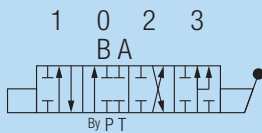

Spool with regenerative circuit in position 3. The regenerative circuit allows the cylinder to increase its speed, in one way only, adding to the pump flow the oil returning from the rod chamber of the cylinder. To be combined only with spool controls 14, 26, 42 or 43. Special machining on the body is required.

## SPOOL WS | 4-WAY / 4-POSITION, REGENERATIVE SPOOL

**Code 560807**

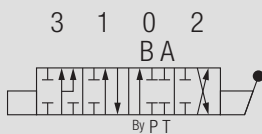

Double-acting spool regenerative in position 3, for valves with right inlet. The regenerative circuit allows the cylinder to increase its speed, in one way only, adding to the pump flow the oil returning from the rod chamber of the cylinder. To be combined only with spool controls 42 or 43. Special machining on the body is required.

## SPOOL R | 4-WAY / 3-POSITION, REGENERATIVE SPOOL

**Code 560474**

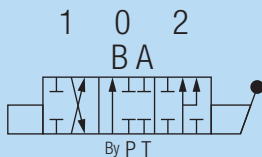

Regenerative spool in position 2. The regenerative circuit allows the cylinder double-acting to increase its speed, in one way only, adding to the pump flow the oil returning from the rod chamber of the cylinder. Special machining on the body is required.

## SPOOL Y | 4-WAY / 3-POSITION SPOOL

**Code 560778**

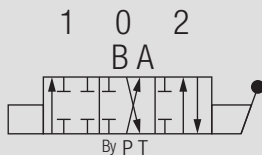

Provides control of bi-directional motors.  
The neutral position is in position 1.  
Special machining on the body required.

## SPOOL M | 4-WAY / 3-POSITION SPOOL

**Code 560143**

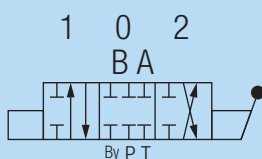

Same features as spool A to be used in a closed center system (i.e. John Deere).



# SPARE PARTS

## SPOOL E | 4-WAY / 3-POSITION SPOOL

Code 560140

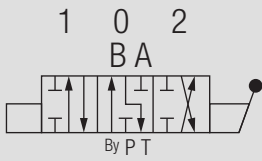

Same features as spool A.  
In position 0 work port B is  
connected to the tank.

## SPOOL F | 4-WAY / 3-POSITION SPOOL

Code 560141

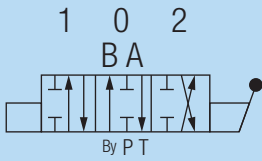

Same features as spool A.  
In position 0 work port A is  
connected to the tank.

# SPARE PARTS

## Spool controls



POSITION 0: P → T  
 POSITION 1: P → B  
 POSITION 2: P → A

**BOLD** = Starting position  
**ORANGE** = Detent position

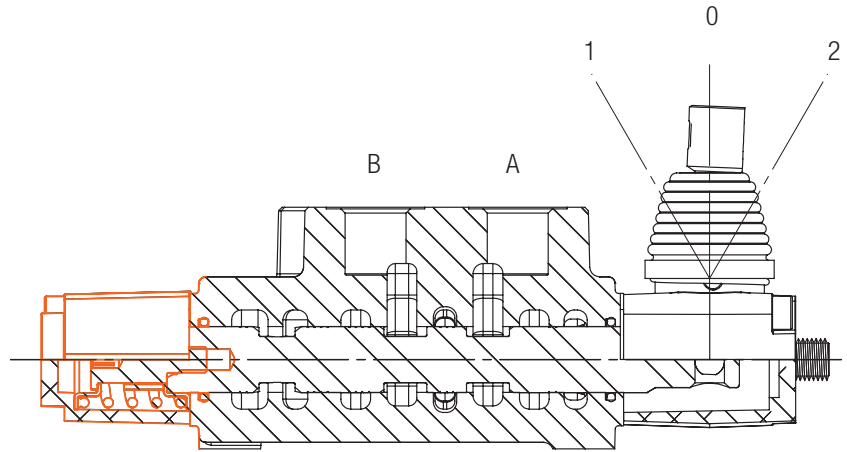

### SPOOL CONTROL 1 | 3 POSITIONS

Code 802127



Allows the spool to move in position 1 and 2 by pushing and pulling the lever: spool goes back to position 0 when the handle is released (Spring return).

### SPOOL CONTROL 2 | 3 POSITIONS

Code 802016



Same features as spool control 1 with 3 positions 0-1-2: when the lever is pushed in position 1 the spool is detented.

### SPOOL CONTROL 3 | 3 POSITIONS

Code 802017



Same features as spool control 1 with 3 positions 0-1-2: when the lever is pulled in position 2 the spool is detented.

# SPARE PARTS

## SPOOL CONTROL 4 | 2 POSITIONS

Code 802018

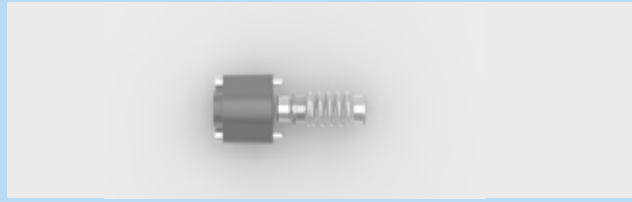
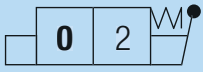

Allows the spool to move only in position 0 and 2: spool goes back to position 0 when the handle is released (Spring return).

## SPOOL CONTROL 5 | 2 POSITIONS

Code 802019



Allows the spool to move only in position 0 and 1: spool goes back to position 0 when the handle is released (Spring return).

## SPOOL CONTROL 6 | 2 POSITIONS

Code 802020

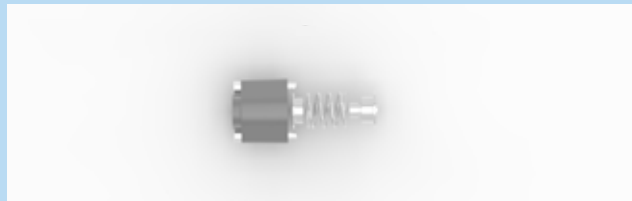
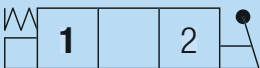

In neutral position, spool is in position 1.  
Pulling the lever spool passes through position 0 and gets to position 2.

## SPOOL CONTROL 7 | 2 POSITIONS

Code 802021



In neutral position, spool is in position 2.  
Pushing the lever spool passes through position 0 and gets to position 1.

## SPOOL CONTROL 8 | 3 POSITIONS

Code 802022

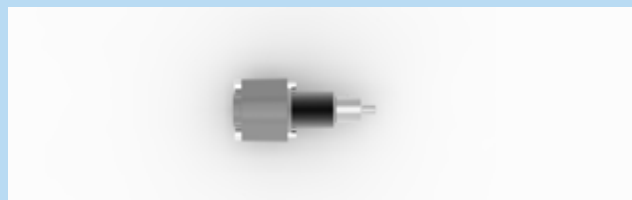

Spool is detented in all positions: 0, 1 and 2.

## SPOOL CONTROL 9 | 2 POSITIONS

Code 802023

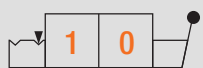

Spool is detented in all positions: 0 and 1.

# SPARE PARTS

## SPOOL CONTROL 10 | 2 POSITIONS

Code 802024

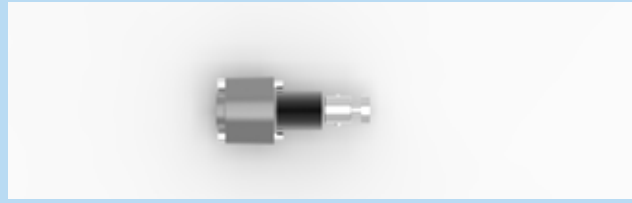

Spool is detented in all positions: 0 and 2.

## SPOOL CONTROL 11 | 2 POSITIONS

Code 802025



Spool is detented in all positions: 1 and 2. Position 0 is absent.

## SPOOL CONTROL 12 | 4 POSITIONS

Code 802026

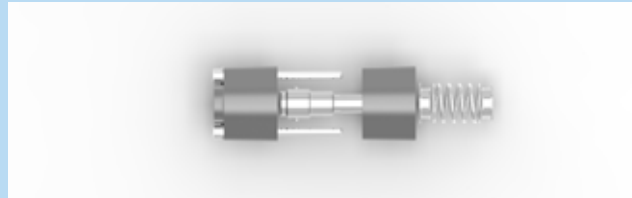
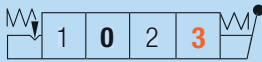

The spool returns to 0 from positions 1 and 2 when the handle is released. Position 3 is detented. To be combined only with spool L.

## SPOOL CONTROL 13 | 4 POSITIONS

Code 802027

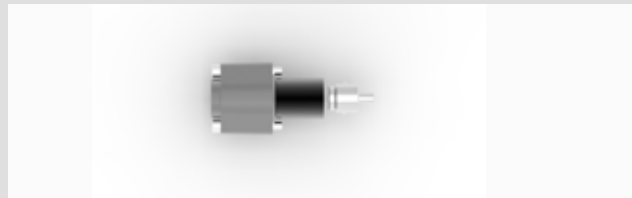
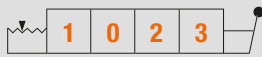

The spool is detented in all positions. To be combined only with spool L.

## SPOOL CONTROL 14 | 4 POSITIONS

Code 802047

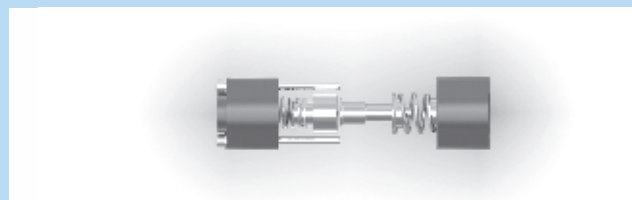
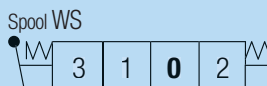

The spool returns to position 0 when the handle is released. To be combined only with spools Z or WS.

## SPOOL CONTROL 26 | 4 POSITIONS

Code 802309



The spool returns to position 1 when the handle is released. The spool is detented in position 2. To be combined only with spools Z or WS.

# SPARE PARTS

## SPOOL CONTROL 40 | 3 POSITIONS

Code 802164

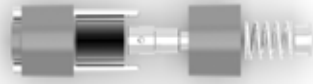
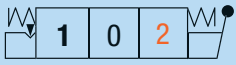

The spool is detented in position 2 and returns to position 1 from position 0 when the handle is released.

## SPOOL CONTROL 42 | 4 POSITIONS

Code 802062

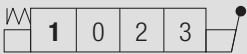

The spool returns to position 1 when the lever is released. To be combined only with spool Z or WS.

## SPOOL CONTROL 43 | 4 POSITIONS

Code 802322

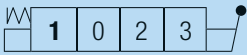

The spool returns to position 1 when the lever is released. To be combined only with spool Z or WS.

## SPOOL CONTROL 1DC | 3 POSITIONS

Code 802097



Same features as spool control 1 with the addition of a threaded pin which allows to operate the spool also from the side opposite to the manual control.

## SPOOL CONTROL 1F | 3 POSITIONS

Code 802356



Same features as spool control 1 with the addition of the connection kit to cable remote control.

To be assembled with manual remote control FO-FA and cable CA.

## SPOOL CONTROL 1P | 3 POSITIONS

Code 802390



Same features as spool control 1 with the addition of the pneumatic remote control.

# SPARE PARTS

## SPOOL CONTROL **1MSW0** | 3 POSITIONS

Code 802262



Same features as spool control 1 with the addition of a waterproof microswitch operating in positions 1 and 2.

## SPOOL CONTROL **1MSW1** | 3 POSITIONS

Code 802263

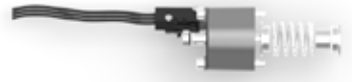

Same features as spool control 1 with the addition of a waterproof microswitch operating in position 1.

## SPOOL CONTROL **1MSW2** | 3 POSITIONS

Code 802264

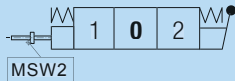

Same features as spool control 1 with the addition of a waterproof microswitch operating in position 2.

## SPOOL CONTROL **1EP** | 12V

Code 801557

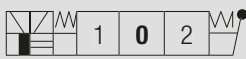

The electro-pneumatic control is used on vehicles equipped with compressed air system.

## SPOOL CONTROL **1EP** | 24V

Code 801558

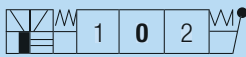

The electro-pneumatic control is used on vehicles equipped with compressed air system.

# SPARE PARTS

## SPOOL CONTROL **1MLAB**

Code 802439

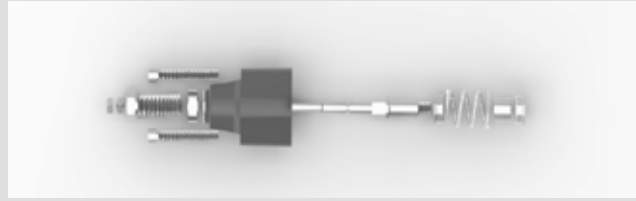

Same features of spool control 1 with the addition of a stroke limiter.

## KIT SPOOL CONTROL **8(DN)** (BM100 ROTATIVO)

Code 802267

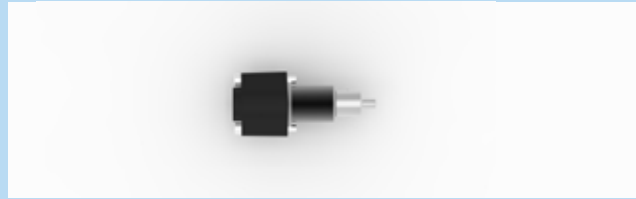

Kit spool control with DACROMET protection against the marine corrosion. It's used with the rotary actuator.

*See page 19 for the characteristics of the rotary actuator.*

## SPOOL CONTROL **2AKO** | 3 POSITIONS

Code 802269

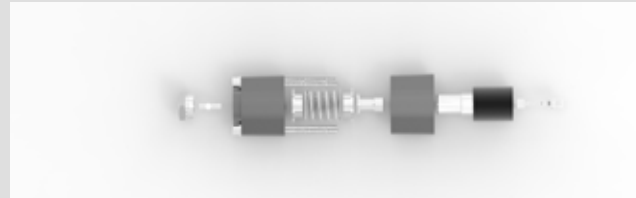
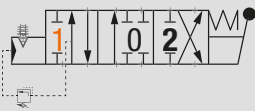

Automatic release adjustable from position 1.

# SPARE PARTS

## Fittings and plugs

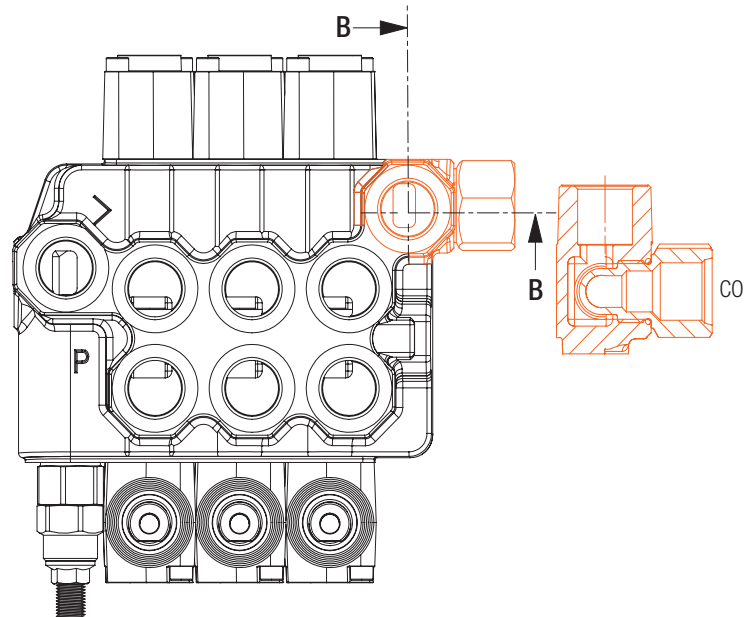
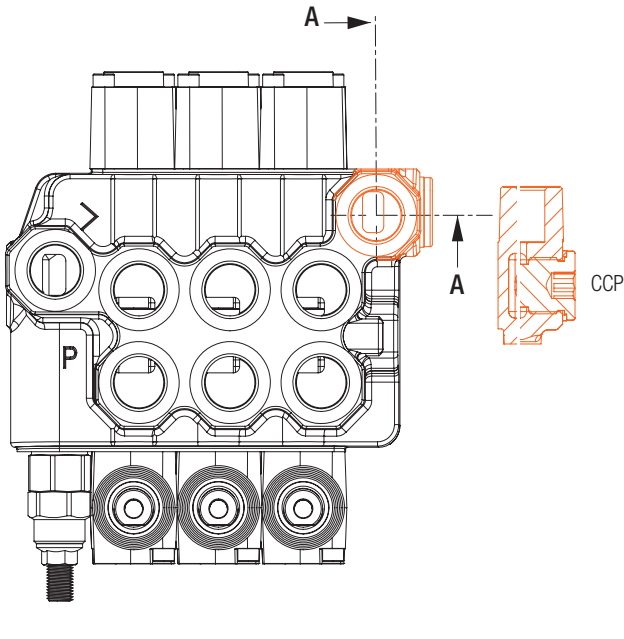

### CLOSED CENTER PLUG **CCP** - 3/4" BSP



Turns an open center circuit into a closed center one. BSP threaded.

Code 832013

### CARRY OVER PLUG (POWER BYOND) **CO** - 3/4" BSP



Allows the installation of another valve downstream the first. To be assembled on T2 port. BSP threaded.

Code 832160

### CLOSED CENTER PLUG **CCP** - 1.1/16" - 12 UNF



Turns an open center circuit into a closed center one. UNF threaded.

Code 832035

### CARRY OVER PLUG (POWER BYOND) **CO** - 1.1/16" - 12 UNF



Allows the installation of another valve downstream the first. To be assembled on T2 port. UNF threaded.

Code 832034



# SPARE PARTS

## Inlet / Outlet / Ports

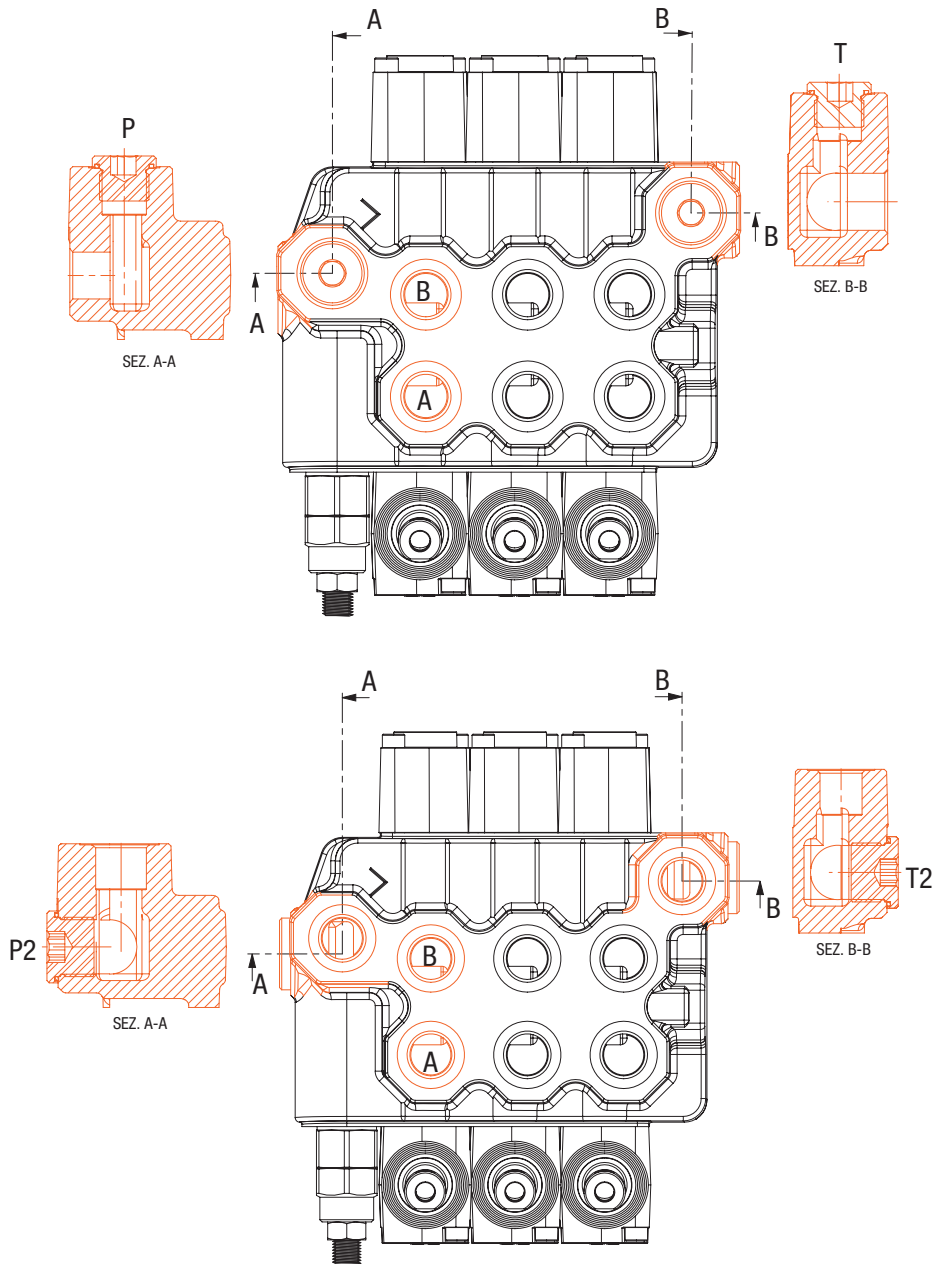

### PLUG 7/8"-14 UNF - Code 015004

**P** - BM70 / BF701  
**T** - BM70 / BF701  
**A / B** - BM70 / BF701

### PLUG 1.1/16-12 UNF - Code 015005

**P** - BM100  
**P2** - BM70 / BM100 / BF701  
**T** - BM100  
**T2** - BM70 / BM100 / BF701  
**A / B** - BM100



### PLUG 1/2" BSP - Code 015007

**P** - BM70 / BF701  
**T** - BM70 / BF701  
**A / B** - BM70 / BF701

### PLUG 3/4" BSP - Code 015010

**P** - BM100  
**P2** - BM70 / BM100 / BF701  
**T** - BM100  
**T2** - BM70 / BM100 / BF701  
**A / B** - BM100

# INSTRUCTIONS

## DESCRIPTION

The purpose of BM70, BM100 and BF701 is to direct the flow circulating in the hydraulic systems, towards the user chosen by the operator (directional spool valves). The function is obtained by moving the spool within a cavity in a controlled and sequential way and opening orifices that, connecting with each other, realize the functional circuits. Functional and construction characteristics are shown in the initial part of the catalogue.

## CHOICE AND USE

Before you choose the correct configuration of BM70, BM100 and BF701

### You must identify:

- Performance (pressure, flow, temperature, reliability).
- Functional characteristics of each BM70, BM100 and BF701.
- Section and hydraulic diagram, actuators and controls.
- The machine in which it is built-in (installation, accessibility, connection of the hoses, tank, filter).

**The choice must be made so that BM70, BM100 and BF701** are used within the performance limits listed in the catalogue and in compliance with the operating conditions given in the table below.

HYDRAULIC FLUID		MINERAL OIL ACCORDING TO DIN 51524
VISCOSITY	Field	10 ÷ 460 mm <sup>2</sup> /sec
	Optimal	12 ÷ 75 mm <sup>2</sup> /sec
TEMPERATURE	Excursion	-20 ÷ +80 °C
	Optimal	+30 ÷ +60 °C
MAXIMUM CONTAMINATION LEVEL (Filtro 25 µ ass. $\eta_x = 75$ )		NAS 1638: CLASS 9 – ISO 4406: 20/19/16
ROOM TEMPERATURE		-30 ÷ +60 °C
PRESSURE AND FLOW		SEE CATALOGUE
PRESSURE DROP		SEE CATALOGUE
OIL VELOCITY IN THE TUBES: INLET AND PORTS		6 ÷ 8 m/sec
OIL VELOCITY IN THE TUBES: RETURN		3 ÷ 4 m/sec

For all uses in which functional and performance conditions **are not referable to this catalogue**, please get in contact with BLB technical department. In case of permitted uses ask for written answers and additional specifications relevant to use.

## SPECIAL PRODUCTS

BM70, BM100 and BF701 are characterized by a high number of possible functional combinations. Products with high customization and combinations might not be identifiable in the catalogue.

For such products, BLB provides the necessary advice to identify the optimal functional composition and supplies the documentation required for the installation and proper use.

## USE

### Authorized use.

All applications that meet the specifications described in the sections "TECHNICAL FEATURES" and "CHOICE AND USE."

### Unauthorized use.

- **Do not use** BM70, BM100 and BF701 in systems **without filtration**.
- **Do not use** BM70, BM100 and BF701 **with fluids other than those listed in the table**.
- **Do not use** BM70, BM100 and BF701 **to hold actuators in a fixed position** for periods of time not compatible with the working pressure. It is strictly prohibited to use BM70, BM100 and BF701 as an holding tool. In all cases in which 0 leakage is required, auxiliary valves, specific for the purpose, have to be installed directly on the actuators.

## SAFETY STANDARDS

The surfaces of BM70, BM100 and BF701 have sharp edges and internal cavities with residual oil. Therefore, during handling operations for storage, control, installation or demolition, testing, maintenance, and disposal it is necessary to:

- Grab the pieces with protective gloves.
- Wear appropriate work clothes and non-slip work shoes.
- Verify the size and weight to use suitable handling equipment.
- Consult the handling mode (see section "Handling and Storage").

## IDENTIFICATION AND PACKAGING

**BM70, BM100 and BF701 valves are delivered in closed single boxes or packages with variable sizes and weights.** Each BM70, BM100 and BF701 valve is identified by a label reporting a 6-digit code and a short description of the product, as well as the production lot or in alternative a laser mark containing the same information.

# INSTRUCTIONS

## CHECKS UPON RECEIPT

**Upon delivery**, please check that:

- Packaging and products have not been damaged during shipping.
- The supply is in accordance with the order.
- Accompanying documents are complete and comprehensive.

In case non-conformity or failures are noticed, notify BLB within eight days from receipt date.

**WARNINGS:** BM70, BM100 and BF701 valves are delivered in oil-proof plastig bags. The internal cavities contain residual oil retained by the protective caps on ports.

**Remove the plastic caps only when the connection hoses have to be assembled.**

## HANDLING AND STORAGE

**Before moving the products** it is important to be aware of the size and weight to be moved.

BM70, BM100 and BF701 valves, should be moved carefully and with adequate means for the size and weight of the package, whether it is a single pack or multi pack. It is necessary to take every precaution measures to prevent damage that could compromise the functional efficiency of the products and the safety of anyone present in proximity of the areas in which you operate.

All BLB products need to be stored in a dry place, protected from weathering and possible damages.

When the secondary packaging is removed, BM70, BM100 and BF701 valves should be stored with the oil-resistant protective bags.

## INSTALLATION

**Before installing the products**, you must check that they have not been damaged during internal handling and storage operations. In case of long storage before usage, please check that the products are complete with all their parts as originally delivered. In particular, for BM70, BM100 and BF701 valves, check that the protective caps have not been removed. In all cases in which the proper operation of the valve is doubtful, make proper tests on bench and replace those parts found faulty (oxidized, damaged, etc...).

**In case of any uncertainty or doubt please contact an authorized BLB service centre.**

Make sure that the system characteristics are those laid down in the project (filtration, oil type and viscosity, temperature control, tank capacity, etc ...).

**IMPORTANT: the installation of BM70, BM100 and BF701** calls for tightening of screws, fittings and hoses. For each of these elements, you must use the appropriate tools and wrenches that allow the control of the tightening torque. Excessive tightening causes deformations to the valve, compromising the correct operation of the same. A weak tightening may affect the functionality and safety. Use the following table to determine the correct tightening torque for each element. Do not use provisional extension and do not act with bumps on the wrenches.

PART		THREAD	Nm
Fixing screws	BM70/100, BF70	M10 x 1,5 8.8	45
Connectors/Plugs		1/2" G ; 7/8" -14 UNF2B	50; 55
		3/4" G ; 1" 1/16-12 UNF2B	95; 100
Valves, plugs	VL80	M24 x 1,5	80

**BM70, BM100 and BF701** installation procedures consist of 3 steps:

### First step: valve fixing.

Prepare the area where BM70, BM100 and BF701 will be placed, in order to ease the assembly, the hose connection and the adjustments during start-up and testing.

Install the valve in shock and vibration-free areas.

While moving the valve do not cause accidental bumps or shocks and follow the indications listed in the "HANDLING" paragraph.

The valve must be secured with M10 screws through the holes provided. Apply thread-lock accessories.

The mounting position is irrelevant as long as the valve is resting on a rigid and perfectly flat surface.

This is necessary so that the tightening of the screws does not cause harmful deformation.

# INSTRUCTIONS

## Second step: hydraulic hoses connection (inlet, ports, tank).

Use hoses and fittings suitable for indicated max flow and pressure.

**It is strictly prohibited the usage of conic fittings and the reversal of connections between inlet (P, P2) and tank (T, T2) lines.**

Remove protective plugs from the valve ports just before connecting the hoses to prevent contamination of the circuit with dust or other materials. Do not use tape wrapped on threads to seal. Tighten the fittings with the torque indicated in the table.

## Third step: Sytem starting

**Before starting, “wash the system”** by fluxing oil from an auxiliary system. Start the system and then operate the actuators individually and not under load.

Operate slowly until the system is filled with oil. Set the relief valves and carry out a complete testing of the system. In case the initial fluxing is not possible, clean the filters at the end of testing.

Do not perform calibration of valves without having first applied a pressure gauge on the inlet section of the valve and on line where deemed necessary.

## MAINTENANCE

### Routine Maintenance

- Periodically check the functionality of the relief valve of **BM70, BM100 and BF701**.
- Periodically clean the filters of the system. Excessive oil contamination causes irregular operation of the spool and of the relief valve.

### Preventative maintenance

- At each oil change of the system replace the filters.
- Check the calibration of the pressure relief valve and replace if deemed no longer reliable.

### Unscheduled maintenance

In case of interventions for which it is necessary to disassemble the valve, consult BLB authorized service centers.

## DEFECTIVENESS AND DISMANTLING

### Defectiveness

BM70, BM100 and BF701 valves are delivered tested. Defectiveness found during the initial installation generally derive from failing to comply with the directions outlined or for damages suffered during transportation.

During the operating time of BM70, BM100 and BF701 valves it is possible to notice the following defectiveness.

### Spool sticking

CAUSE	CORRECTIVE ACTION
Excessive working pressure	Check the working pressure and the valves settings. Eliminate water hammer (pressure peaks).
Excessive oil contamination	Replace oil and filters. Wash the system with auxiliary fluxing. Carry out maintenance at shorter intervals.
Valve not suitable for the application	Check and in case review the choice of the valve.
Additional controls and actuators	Check or change the additional actuators.
Over-tightening of the fixing screws	Loosen fittings and fastening screws.
Support base with severe geometric errors (not flat)	Adopt additional brackets or elastic elements.
Excessive working temperature	Check the valves setting and the pressure drops of the system.

### Oil leakage at the spool

CAUSE	CORRECTIVE ACTION
Excessive working temperature	Increase the amount of oil in the system (by increasing the tank size). Decrease the pressure drop in the system. Improve the oil cooling. Check or change the valves setting. Replace seals or complete relief valves.
Excessive oil pressure	Check the working pressure and the valves settings. Eliminate water hammer (pressure peaks).
Valve not suitable for the application	Check and in case review the choice of the valve.
Seals worn or broken	Replace the seals.
Excessive flow for the valve	Loosen fittings and fastening screws.
Backpressure on tank line	Check for possible tight spots towards tank.

# INSTRUCTIONS

## Excessive internal leakage

CAUSE	CORRECTIVE ACTION
Excessive working pressure	Check the working pressure and the valves settings. Eliminate water hammer (pressure peaks).
Excessive temperature of oil	Improve the oil cooling. Check or change the valves setting. Replace seals or complete relief valves.
Unsuitable application	Check and in case review the choice of the valve.
Valve seals worn or broken	Replace seals or complete relief valves.

## Spare parts

The spare parts available are shown in this catalogue.

Replace the parts to be changed only with **original spare parts**.

To correctly perform any replacements, comply with the relevant technical specifications (sheets, assemblies, bill of materials, procedures) provided by Blb.

## Dismantling

BM70, BM100 and BF701 valves no longer usable must be disassembled to split the parts constituting them. Separate the metal parts from those in synthetic material or rubber.

Do not dispose part and the residual oil in them contained in the environment.

## WARRANTY AND LIABILITY LIMITS

BLB products are exclusively appointed to professional operators and users. Therefore, in warranty topics, it is not applied the discipline of Decree-Law no. 24 of 02-02-2002 in performance of European Directive 1999/44/EC.

All products are warranted for a period of **12 (twelve) months** from date of shipment from BLB to be free from defects in materials and workmanship under:

- Correct use.
- Normal operating conditions.
- Proper application.

BLB's obligation under this warranty is limited, at BLB's option, ex-factory, to the repair or exchange, of any BLB product or part, which proves to be defective as provided herein.

BLB reserves the right to either inspect the product at Buyer's location or require it to be returned, free of charge, to the factory for inspection. Any description of goods, including any reference to Buyer's specification and any description in catalogues, circulars and other written material published by BLB is for the sole purpose of identifying the products and does not create an express warranty that the goods conform to the sample or model.

Buyer is the sole responsible for determining the suitability of goods sold hereunder for Buyer's use.

BLB reserves the right to discontinue, modify or revise the specifications of the products described herein. All details and components may vary depending on the installation.

The above warranty does not extend to all parts typically subjected to sliding or rolling friction and wear.

The warranty is also excluded on parts potentially subjected to oxidation or corrosion if not properly used or maintained.

The above warranty does not extend to goods damaged or subjected to accident, abuse or misuse after shipment from BLB's factory nor to goods altered or repaired by anyone other than authorized BLB's representatives.

BLB will in no event be liable for any incidental or consequential damage nor for any sum in excess of the price received for the goods for which liability is claimed. Equipment manufactured by third parties and included in the supply together with the material produced by BLB are subjected to the warranty conditions of the parts producer.

BLB is not subjected to warranty obligations on breakdowns, damages, malfunctions, failures, or inefficiency resulting from wrong installation, intentional or unintentional tampering, poor maintenance, negligence or incompetence of the end user.

Modifications or repairs carried out by people not specifically authorized in writing by BLB will invalidate the warranty.

Late or non-payment, even partial, of the supplies cancels the warranty.

Warranty conditions do not confer to the customer the right to suspend or defer the payments which will have to be made in any case under the conditions agreed and specified in the BLB order confirmations. BLB reserves the right to cancel the warranty if:

- Labels or tags with the producer mark, product code and serial number have been deleted or removed.
- The product has been modified or machined without express authorization given by BLB.
- The product has not been used in accordance with the instructions provided or for purposes other than those for which it has been designed.

Warranty is recognized only to BLB's direct customers. Anyone in possession of BLB products, which however have been bought through third parties (distributors, dealers, installers or manufacturers of any kind), will have to contact the direct supplier for any eventual warranty claim.

## THERE ARE NO EXPRESS WARRANTIES OTHER THAN THOSE SPECIFICALLY DESCRIBED HEREIN.

The Court of Justice of BLB's seat (Vicenza – Italy) is the only competent for any controversy.

## TERMS & CONDITIONS OF SALE

General sales conditions may differ from Country to Country.

BLB sales department will send all necessary information upon request. For anything not specified herein, the norms of the Civil Code in matter apply.







Nr 50 100 11533

**BLB S.r.l.**  
Via Natta, 1  
36040 Brendola (VI)  
Italy

**T.** +39 0444 401141  
**F.** +39 0444 401086  
**W.** [www.blbhydraulic.com](http://www.blbhydraulic.com)  
**E.** [info@blbhydraulic.com](mailto:info@blbhydraulic.com)