

Modular cartridge valves type LIMP, LIRP, LICP

Pressure controls: relief, reducing, compensator, ISO 7368 size from 16 to 80

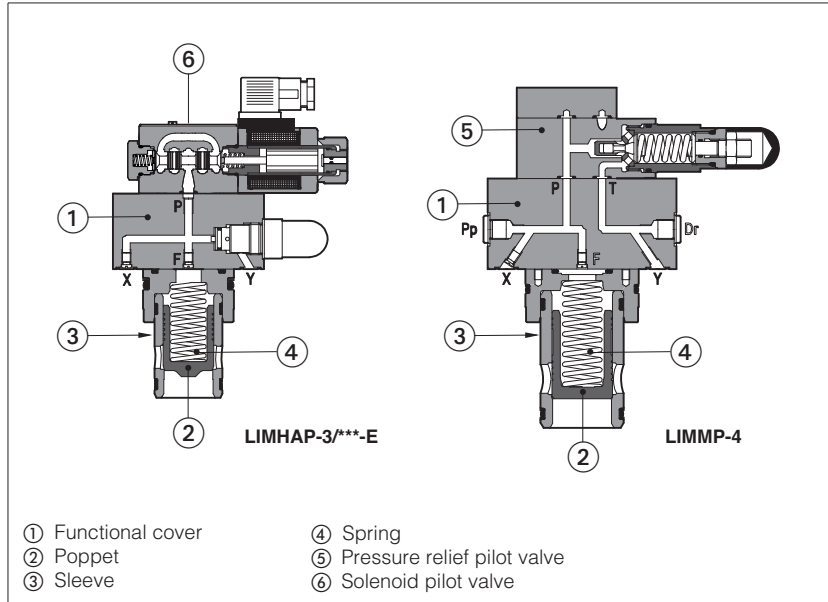

Pressure control valves in ISO cartridge design specific for relief, reducing or compensator functions

They are made by a functional cover ① provided with the oil ports X, Y, F for the cartridge piloting, and a slip-in cartridge

Depending to the type of function, the cover is equipped with a pilot relief valve ⑤ for the max pressure regulation and a solenoid valve ⑥ for venting

The slip-in cartridge, to be housed into an ISO cavity, is available in different models to optimize the pressure control, see section ④

The cartridge is made by a poppet ② sliding into a sleeve ③ and kept in normally closed position by the spring ④ available with different cracking pressure values

Size: **16 to 80** (ISO 7368)
 Max flow up to **5000 l/min** at $\Delta p = 5$ bar
 Max pressure up to **420 bar**

1 MODEL CODE OF FUNCTIONAL COVERS

LI	MHA	P	-1	/210	/V	-I	X	24DC	**	/*	F**
Cover according to ISO 7368											Optional different setting of the calibrated plugs in the pilot channels, see section ④, ⑦
Function: MM = pressure relief control with manual setting; MHA = pressure relief control with solenoid valve for venting. Unloading when solenoid is deenergized; MHC = pressure relief control with solenoid valve for venting. Unloading when solenoid is energized; RA = pressure reducing control with manual setting. Open in resting position; C = pressure compensator to be coupled with flow control valves; CM = pressure compensator with mechanical max pressure regulation to be coupled with flow control valves.											Seals material: - = NBR PE = FKM BT = HNBR
P = high pressure execution, Pmax 420 bar Size: 1 = 16; 2 = 25; 3 = 32; 4 = 40; 5 = 50; 6 = 63; 8 = 80 LIRA is available only in size 16, 25, 32, 40 Pressure range: 50 = 6 ÷ 50 bar; 210 = 10 ÷ 210 bar; 420 = 25 ÷ 420 bar; 100 = 8 ÷ 100 bar; 350 = 15 ÷ 350 bar;											Series number Voltage code only for LIMHP, see section ⑨ Only for LIMHAP and LIMHCP X = without connector 00 = solenoid valve without coils (for -I) 00-AC = AC solenoid valve without coils (for -E) 00-DC = DC solenoid valve without coils (for -E) See tech. table K500 for available connectors, to be ordered separately
											Pilot valve only for LIMHAP and LIMHCP: -I = DHI for AC and DC supply, Pmax 350 bar -E = DHEP for AC and DC supply, high performances solenoids, Pmax 420 bar
											Options: see section ④

For model code of slip-in cartridge, see section ③

2 HYDRAULIC SYMBOLS

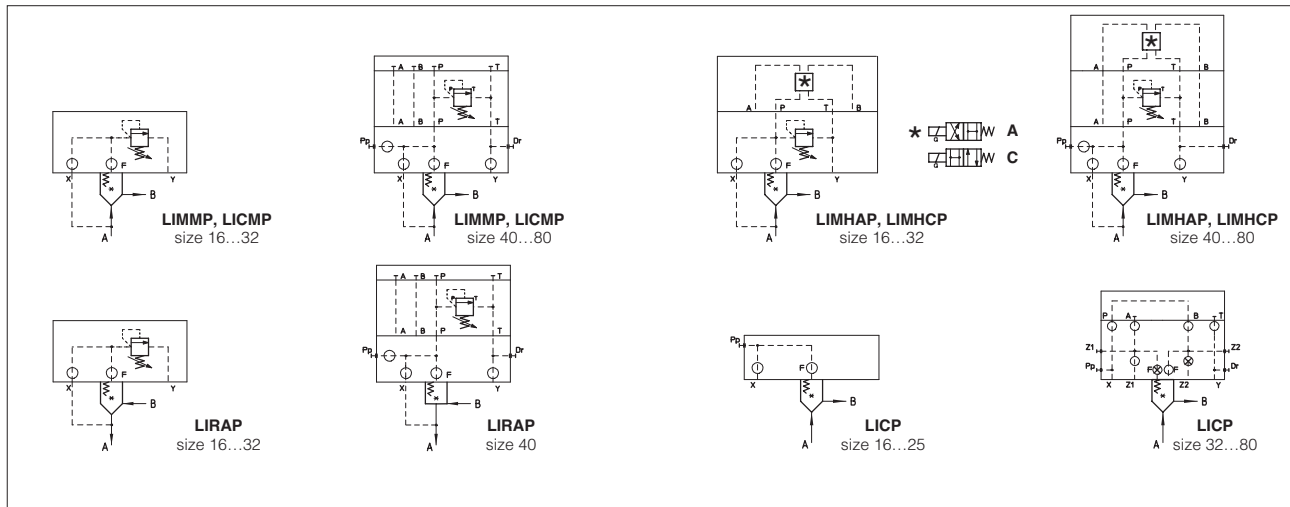

3 MODEL CODE FOR POPPET

SC LI - 16 31 2 ** /*

Cartridge according to ISO 7368

Size, the same of relevant cover:
16 = 16; **32** = 32; **50** = 50; **80** = 80
25 = 25; **40** = 40; **63** = 63;

Type of poppet
31 = (sizes 16...80) = for LIMM, LIMH*, LIC, LICM
34 = (size 16) = for LIMM, LIMH*
35 = (sizes 16...50) = for LIMM, LIMH*
36 = (sizes 16...80) = for LIC, LICM
37 = (sizes 16...40) = for LIRA

Seals material:
 - = NBR
PE = FKM
BT = HNBR

Series number

Spring cracking pressure:
1 = 0,3 bar for poppet 35;
2 = 1,2 bar for poppet 31, 34, 35;
3 = 3 bar for poppet 31, 34, 35;
4 = 4 bar for poppet 37;
6 = 6 bar for poppet 31, 34, 35, 36;
7 = 7 bar for poppet 37 (not available for size 40);

4 TYPE OF POPPETS

Code of poppet	31	34	35	36	37
Functional sketch (Hydraulic symbol)					
Typical section					
Area ratio A: AP	1:1	1:1	1:1,1	1:1	1:1

5 MAIN CHARACTERISTICS SEALS AND HYDRAULIC FLUIDS

Assembly position / location	Any position		
Subplate surface finishing	Roughness index Ra 0,4 - flatness ratio 0,01/100 (ISO 1101)		
MTTFd values according to EN ISO 13849	150 years, for further details see technical table P007		
Ambient temperature	Standard execution = -30°C ÷ +70°C /PE option = -20°C ÷ +70°C /BT option = -40°C ÷ +70°C		
Seals, recommended fluid temperature	NBR seals (standard) = -20°C ÷ +60°C, with HFC hydraulic fluids = -20°C ÷ +50°C FKM seals (/PE option) = -20°C ÷ +80°C HNBR seals (/BT option) = -40°C ÷ +60°C, with HFC hydraulic fluids = -40°C ÷ +50°C		
Recommended viscosity	15 ÷ 100 mm ² /s - max allowed range 2.8 ÷ 500 mm ² /s		
Fluid contamination class	ISO 4406 class 21/19/16 NAS 1638 class 10, in line filters of 25 μm (β ₂₅ ≥ 75 recommended)		
Hydraulic fluid	Suitable seals type	Classification	Ref. Standard
Mineral oils	NBR, FKM, HNBR	HL, HLP, HLPD, HVL, HVLDP	DIN 51524
Flame resistant without water	FKM	HF, HFDR	ISO 12922
Flame resistant with water	NBR, HNBR	HFC	
Flow direction	As shown in the symbols of table 2		
Operating pressure	all models except LIMH*		
	Ports A, B, X: 420 bar;		
	LIMH*-I Ports A, B, X: 350 bar; Port T 120 bar		
Maximum flow	Ports A, B, X: 420 bar; Port T 210 bar for DC version; 160 bar for AC version		
Maximum flow	See diagrams Q/Δp at section 8		

5.1 Coils characteristics

Insulation class	Pilot valve -E: H (180°C) for DC coils F (155°C) for AC coils Pilot valve -I: H (180°C) for DC or AC coils Due to the occurring surface temperatures of the solenoid coils, the European standards EN ISO 13732-1 and EN ISO 4413 must be taken into account
Protection degree to DIN EN 60529	IP 65 (with connectors 666, 667, 669 correctly assembled)
Relative duty factor	100%
Supply voltage and frequency	See electric feature 9
Supply voltage tolerance	± 10%
Certification	cURus North American Standard

6 OPTIONS

Only for LIMMP (size 16...32):

/P = predisposed for ISO 4401 size 06 mounting surface

Handwheel for pressure control, only for LIMMP, LIMHP*, LIRAP, LICMP (see tech. table K150):

/V = regulating handwheel (available for all the sizes)

/VF = regulating knob (available only for sizes 40...80)

/VS = manual override with safety locking (available only for sizes 40...80)

/WV = prolonged manual override protected by rubber cap for pilot solenoid valve

For all the models:

******* = calibrated plugs different from standard one. The restrictors configuration (if different from the standard) must be indicated at the end of the model code:

LIMHAP - 1 /210 -IX 24DC **

F

06

Channel where the orifice has to be provided:
X = channel X
F = channel F

Size of the throttling hole in tenths of millimeters:
05 = 0,5 mm **10** = 1 mm
06 = 0,6 mm **12** = 1,2 mm
08 = 0,8 mm **15** = 1,5 mm

7 STANDARD ORIFICES CONFIGURATION

Port \ Cover																									
	LIM*-1	LIRA-1	LICM-1	LIC-1	LIM*-2	LIRA-2	LICM-2	LIC-2	LIM*-3	LIRA-3	LICM-3	LIC-3	LIM*-4	LIRA-4	LICM-4	LIC-4	LIM*-5	LICM-5	LIC-5	LIM*-6	LICM-6	LIC-6	LIM*-8	LICM-8	LIC-8
X	M4 10A	M4 08A	M4 08A	- -	M4 10A	M4 08A	M4 08A	- -	M6 10A	M6 08A	M6 12A	M6 10A	M6 10A	M6 12A	M6 10A	M6 10A	M6 10A	M6 10A	M6 10A	M6 10A	M6 10A	M6 10A	M8 10A	M8 10A	M8 10A
F	M4 12F	M4 12A	M4 05F	M4 05F	M4 12F	M4 12A	M4 05F	M4 05F	M6 12F	M6 12A	M6 12F	M6 05F	M6 12F	M6 08A	M6 12F	M6 12F	M6 12F	M6 12F	M6 12F	M6 12F	M6 12F	M6 12F	M8 12F	M8 12F	M8 12F

M4 ÷ M8 = screw size; 10A ÷ 12F = calibrated orifice diameter in tenths of mm; A or F defines the orifice shape

8 FLOW /Δp DIAGRAMS BASED ON MINERAL OIL

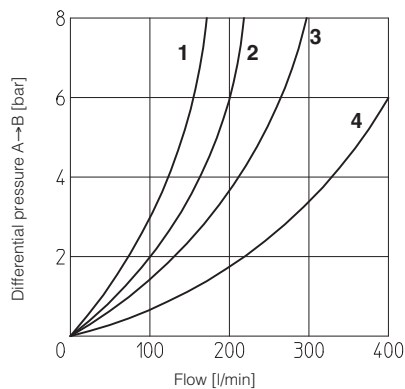

1 = SC LI-1637
2 = SC LI-1634
3 = SC LI-2537
4 = SC LI-2535

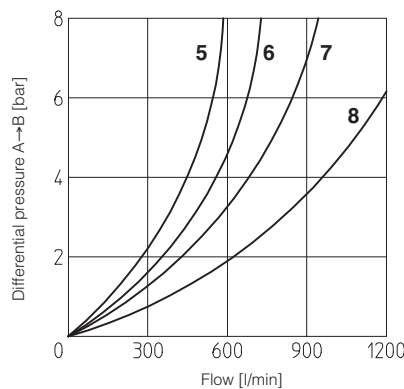

5 = SC LI-3237
6 = SC LI-3235
7 = SC LI-4037
8 = SC LI-4035

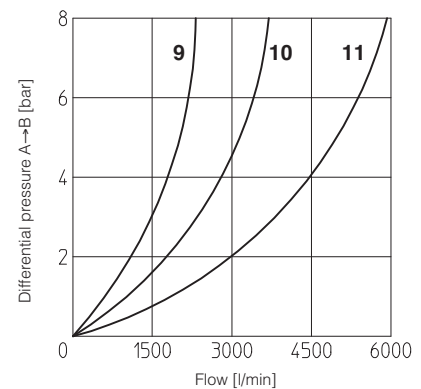

9 = SC LI-5035
10 = SC LI-6331
11 = SC LI-8031

9 ELECTRIC FEATURES

Solenoid valve type	External supply nominal voltage ± 10% (1)		Voltage code	Type of connector	Power consumption (3)	Code of spare coil DHI	Colour of coil label DHI	Code of spare coil DHEP
	DC	AC						
DHI DHEP	DC	12 DC 24 DC 110 DC 220 DC	12 DC 24 DC 110 DC 220 DC	666 or 667	33 W (DHI) 30 W (DHEP)	COU-12DC COU-24DC COU-110DC COU-220DC	green red black black	COE-12DC COE-24DC COE-110DC COE-220DC
	AC	110/50 AC (2) 115/60 AC 120/60 AC 230/50 AC (2) 230/60 AC	110/50/60 AC 115/60 AC (5) 120/60 AC (6) 230/50/60 AC 230/60 AC	666 or 667	60 VA (DHI) 58 VA (DHEP) (4)	COI-110/50/60AC - COI-120/60AC COI-230/50/60AC COI-230/60AC	yellow - white light blue silver	COE-110/50/60AC COE-115/60AC - COE-230/50/60AC COE-230/60AC

- (1) For other supply voltages available on request see technical tables E010, TE030.
- (2) Coil can be supplied also with 60 Hz of voltage frequency: in this case the performances are reduced by 10 ÷ 15% and the power consumption is 55 VA (DHI)
- (3) Average values based on tests performed at nominal hydraulic condition and ambient/coil temperature of 20°C.
- (4) When solenoid is energized, the inrush current is approx 3 times the holding current. Inrush current values correspond to a power consumption of about 150 VA.
- (5) Only for DHEP (6) Only for DHI

10 COVER DIMENSIONS [mm] - for mounting interface and cavity dimensions see tech. table P006

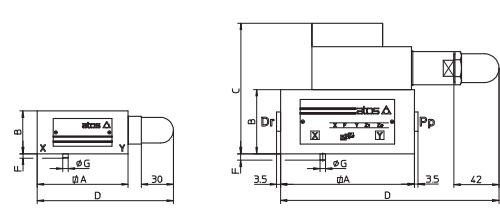

LIMMP (size 16...32)
LIRAP (size 16...32)
LICMP (size 16...32)

LIMMP (size 40...80)
LIRAP (size 40)
LICMP (size 40...80)

Covers	A	B	C	D	F	G	Port Pp-Dr	Seals	Fastening bolts (2)	Tightening torque [Nm]	Weight [Kg]
LIMMP-1 LIRAP-1 LICMP-1	65	40	-	107,5	4	3	-	2 OR 108	Nr. 4 M8x45	35	1,7
LIMMP-2 LIRAP-2 LICMP-2	85	40	-	127,5	6	5	-	2 OR 108	Nr. 4 M12x45	125	2,2
LIMMP-3 LIRAP-3 LICMP-3	100	50	-	142,5	6	5	-	2 OR 2043	Nr. 4 M16x55	300	3,5
LIMMP-4 LIRAP-4 LICMP-4	125	60	122	195	6	5	G 1/4	2 OR 2050	Nr. 4 M20x70	600	8,9
LIMMP-5 LICMP-5	140	70	132	202,5	4	6	G 1/4	2 OR 2050	Nr. 4 M20x80	600	12,4
LIMMP-6 LICMP-6	180	80	142	222,5	4	6	G 3/8	2 OR 2056	Nr. 4 M30x90	2100	21,6
LIMMP-8 LICMP-8	Ø250	80	172	257,5	6	8	G 3/8	2 OR 123	Nr. 8 M24x90	1000	30,5

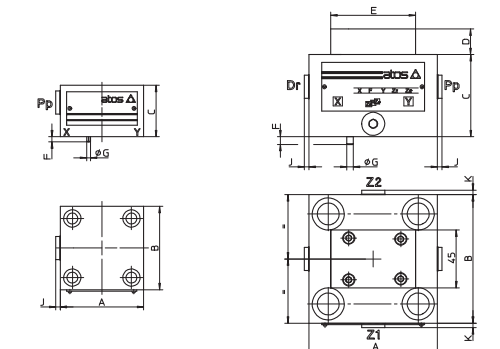

LICP (size 16 ÷ 25)

LICP (size 32...80)

Covers	A	B	C	D	E	F	G	K	J	Port Pp-Dr	Port Z1-Z2	Seals	Fastening bolts (2)	Tightening torque [Nm]	Weight [Kg]
LICP-1	65	65	40	-	-	4	3	-	3,5	G 1/4	-	2 OR 108	Nr. 4 M8x45	35	1,4
LICP-2	85	85	40	-	-	6	5	-	3,5	G 1/4	-	2 OR 108	Nr. 4 M12x45	125	1,8
LICP-3	100	100	50	20	66	6	5	-	3,5	G 1/4	-	4 OR 2043	Nr. 4 M16x55	300	2,3
LICP-4	125	125	60	20	66	6	5	-	3,5	G 1/4	-	4 OR 2050	Nr. 4 M20x70	600	6,2
LICP-5	140	140	70	20	66	4	6	3,5	3,5	G 1/4	G 1/4	4 OR 2050	Nr. 4 M20x80	600	9,3
LICP-6	180	180	80	20	66	4	6	3,5	3,5	G 3/8	G 3/8	4 OR 2056	Nr. 4 M30x90	2100	17,1
LICP-8	Ø 250	-	80	30	73	6	8	-	3,5	G 3/8	-	4 OR 123	Nr. 8 M24x90	1000	27

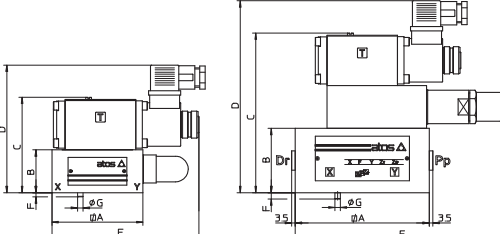

LIMHAP (size 16...32)

LIMHCP (size 40...80)

Covers	A	B	C max	D max	E	F	G	Port Pp-Dr	Seals	Fastening bolts (2)	Tightening torque [Nm]	Weight [Kg]
LIMHAP-1 LIMHCP-1	65 (1)	40	87,5	123,5	124,5	4	3	-	2 OR 108	Nr. 4 M8x45	35	3
LIMHAP-2 LIMHCP-2	85	40	87,5	123,5	134,5	6	5	-	2 OR 108	Nr. 4 M12x45	125	3,3
LIMHAP-3 LIMHCP-3	100	50	130,5	153,5	142,5	6	5	-	2 OR 2043	Nr. 4 M16x55	300	5
LIMHAP-4 LIMHCP-4	125	60	150,5	183,5	195	6	5	G 1/4	2 OR 2050	Nr. 4 M20x70	600	9,2
LIMHAP-5 LIMHCP-5	140	70	160,5	193,5	202,5	4	6	G 1/4	2 OR 2050	Nr. 4 M20x80	600	13,2
LIMHAP-6 LIMHCP-6	180	80	170,5	203,5	222,5	4	6	G 3/8	2 OR 2056	Nr. 4 M30x90	2100	22,5
LIMHAP-8 LIMHCP-8	Ø 250	80	200,5	233,5	257,5	6	8	G 3/8	2 OR 123	Nr. 8 M24x90	1000	31,3

- (1) Cover is not squared: 65x80
- (2) Hexagon socket head screw according to DIN 912 class 12.9

Overall dimensions refer to the pilot valves with connectors type 666