

Stainless steel valves for corrosive environments & water base fluids

ex-proof solenoid valves, Multicertification ATEX, IECEx, EAC or cULus certification

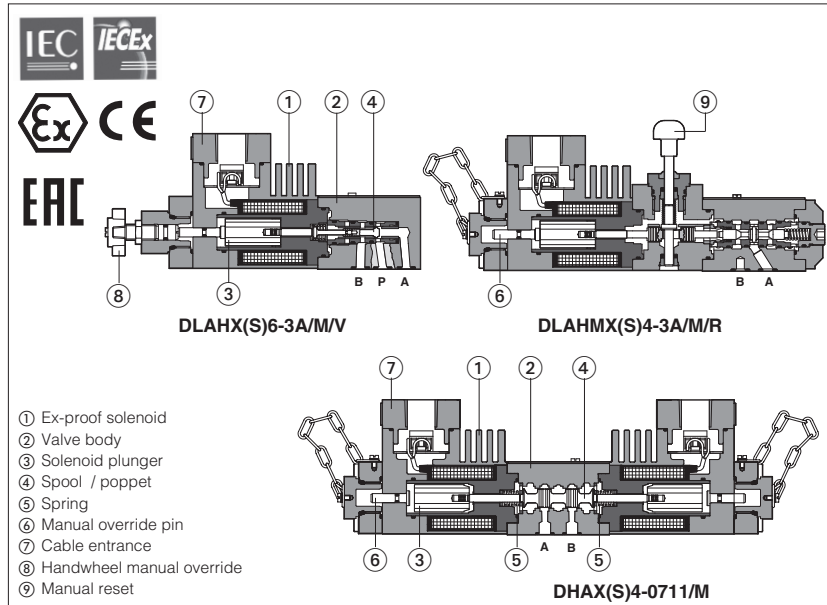

New line of directional solenoid valves and pressure relief valves in stainless steel execution for corrosive environments. Ex-proof Stainless steel solenoids ①, with **ATEX, IECEx, EAC Multicertification** or **cULus** North American certification, for hazardous areas - see section 5, 6.

Two executions are available:

- **X** stainless steel for external and internal parts, to withstand extreme and corrosive environmental conditions, and to ensure full compatibility also with water base and special fluids.
- **XS** stainless steel for external parts to withstand extreme and corrosive environmental conditions. Internal components are derived from standard valves.

Directional valves are available in two basic versions: poppet type, 3-way leak free (suitable for accumulator systems) or spool type, 4-way on-off valves.

DHAX(S) and DLAHX(S) valves are **SIL** compliance with IEC 61508 (TÜV certified) - see section 1.1

1 STAINLESS STEEL VALVES: MAIN DATA

Valve execution (1)		Description	ISO size	Voltages		ATEX, IECEx		cULus		Max flow l/min	Δp (at max flow) bar	Max pressure bar (3)
X (5)	XS			DC	AC 50/60Hz	T class (1)	Input Power	T class (1)	Input Power			
DHAX4	DHAXS6 DHAXS4	4 way, spool type direct solenoid valves	06 (ISO4401)	12 24 48 110 220	12 24 110 230	T6, T4 T4, T3	8 W 25 W	(2) T4	12 W 33 W	60 70	see diagram at section 11	350
DLAHX6 DLAHX4	DLAHXS6 DLAHXS4	3 way, poppet type, direct solenoid valves	06 (ISO4401)			T6, T4 T4, T3	8 W 25 W	(2) T4	12 W 33 W	10 12		315 350
DLAHMX4	DLAHMXS6 DLAHMXS4	3 way, poppet type, direct solenoid valves	06 (ISO4401)			T6, T4 T4, T3	8 W 25 W	(2) T4	12 W 33 W	25 30		250 315
DLAHPX6	DLAHPXS6	3 way, poppet type, piloted solenoid valve	06 (ISO4401)			T6, T4	8 W	-	12 W	40		315
DLAPX6	DLAPXS6	3 way, poppet type, piloted solenoid valve	no			T6, T4	8 W	(2)	12 W	220		315
DLHPX	DLHPXS	3 way, poppet type, hydraulic operated valve	06 (ISO4401)			-	-	-	-	40		315
DLPX	DLPXS	3 way, poppet type, hydraulic operated valve	no			-	-	-	-	220		315
CART-MX-3 CART-MX-6 CART AREX-20	CART-MXS-3 CART-MXS-6 CART AREXS-20	relief valve direct screw-in	no no no	- - -	- - -	- - -	- - -	- - -	2,5 40 (60 PED) 120 (150 PED)	30	420 500 400	
HMPX-*	HMPXS-*	relief valve direct modular	06 (ISO4401)	-	-	-	-	-	40	35	350	
SC LIX-2531* LIMMX-2*	LIMMXS-2*	relief valve DIN cartridge (4)	25 (ISO7368)	-	-	-	-	-	400	6	350	

Notes:

- (1) **XS6** and **XS4** versions differ only for the coil power (see Input Power) - For ATEX, IECEx, EAC multicertification the temperature class T6, T4, T3 is related to the max ambient temperature, from which results the max solenoid surface temperature allowed in the application (see section 3). The reference ambient temperature is **-40÷+40°C** (+45°C for X*6), for higher ambient temperature (-40÷+70 °C) the temperature class has to be degraded. For cULus certification the temperature class is related to the coil power 12W or 33 W
Special execution for ambient temperature -60°C (option /BBT) available on request
- (2) For cULus certification the temperature class corresponding to the coil power 12W is not reported in the nameplate marking. For coil power 33W the temperature class is T4.
- (3) Max pressure on **T** port = **110 bar**
- (4) Optional electrohydraulic venting available on request.
- (5) The "X" valves in full stainless steel execution are factory tested by Atos with mineral oil or pure water in order to avoid the contamination of the end user system. At the end of each valve model code must be specified the type of fluid to be used in the valve's testing: "H" for hydraulic oil or "W" for pure water.

Ambient temperature:

Valves are provided by HNBR seals, which allow min ambient temperature down to -40 °C (max oil viscosity = 380 cSt). The min ambient temperature for valves with /PE option (FKM seals) is -20°C
Max ambient temperature for valves without solenoids is 70°C.

1.1 SIL compliance with IEC 61508: 2010

DHAX(S), DLAHX(S) meets the requirements of:

- **SC3** (systematic capability)
- max **SIL 2** (HFT = 0 if the hydraulic system does not provide the redundancy for the specific safety function where the component is applied)
- max **SIL 3** (HFT = 1 if the hydraulic system provides the redundancy for the specific safety function where the component is applied)

2 MATERIALS SPECIFICATION

Valve type	solenoid housing ①	valve body ②	internal parts for X execution ③ + ④	internal parts for XS execution ③ + ④	spring ⑤	seals	
						std	/PE
DHAX(S)	AISI 630	AISI 316L	AISI 316L, 420B, 440C, 430F	Carbon steel	AISI 302	HNBR (buna)	FKM (viton)
DLAHX(S) DLAHMX(S)	AISI 630	AISI 316L	AISI 316L, 420B, 440C, 430F	Carbon steel	AISI 302	HNBR (buna)	FKM (viton)
DLAHPX(S)	AISI 630	AISI 630	AISI 316L, 420B, 440C, 430F	Carbon steel	AISI 302	HNBR (buna)	FKM (viton)
DLHPX(S)	-	AISI 630	AISI 420B	Carbon steel	AISI 302	HNBR (buna)	FKM (viton)
DLAPX(S)	AISI 630	AISI 630	AISI 316L, 420B, 440C, 430F	Carbon steel	AISI 302	HNBR (buna)	FKM (viton)
DLPX(S)	-	AISI 630	AISI 420B	Carbon steel	AISI 302	HNBR (buna)	FKM (viton)
CART-*X(S)	-	AISI 316L	AISI 316L, 420B, 630	Carbon steel	AISI 302	HNBR (buna)	FKM (viton)
HMPX(S)	-	AISI 316L	AISI 316L, 420B, 630	Carbon steel	AISI 302	HNBR (buna)	FKM (viton)
LIMMX(S)	-	AISI 316L	AISI 316L, 420B, 630	Carbon steel	AISI 302	HNBR (buna)	FKM (viton)
SC LIX	-	AISI 316L	AISI 630, AISI 420B	-	AISI 302	HNBR (buna)	FKM (viton)

3 EX-PROOF SOLENOIDS: MAIN DATA

VALVE TYPE		DHAXS6 DLAHX6 DLAHXS6 DLAPXS6	DLAHMXS6 DLAHPXS6 DLAPX6 DLAHPX6	DHAX4 DHAXS4 DLAHMX4 DLAHX4	DLAHXS4 DLAHMXS4
Solenoid code	Multicertification	OAX/WP, OAXS/WP		OAKX/WP, OAKXS/WP	
	cULus	OAXL/WP, OAXLS/WP		OAKL/WP, OAKXS/WP	
Voltage code	Vdc ±10% VAC 50/60 Hz ±10%	12DC, 24DC, 48DC (1), 110DC, 220DC 12AC, 24AC, 110-120AC, 230-240AC			
Power consumption	Multicertification	8W		25W	
	cULus	12W		33W	
Coil insulation		Class H			
Protection degree		IP 66/67 According to IEC 144 when correctly coupled with the relevant cable gland PAXMC/M			
Duty factor		100%			
Mechanical construction		Flame proof housing classified Ex d, according to EN 60079-0: 2006, EN 6079-1: 2007			
Cable entrance and electrical wiring		Internal terminal board for cable connection threaded connection for cable entrance vertical (standard) or Horizontal (option /O)			
Method of protection		Ex d			
Temperature class (surface temperature)	Multicertification	T6 (≤ 85°C)	T4 (≤ 135°C)	T4 (≤ 135°C)	T3 (≤ 200°C)
	cULus	Not applicable		T4 (≤ 135°C)	
Ambient temperature	Multicertification	-40 ÷ +45 °C	-40 ÷ +70 °C	-40 ÷ +40 °C	-40 ÷ +70 °C
	cULus	-40 ÷ +70 °C			

Notes: (1) 48DC only for Multicertification

For alternating current supply a rectifier bridge is integrated in the solenoid

4 MAIN CHARACTERISTICS, SEALS AND HYDRAULIC FLUIDS - for other fluids not included in below table, consult our technical office



Assembly position / location	Any position for all valves		
Subplate surface finishing	Roughness index Ra 0,4 - flatness ratio 0,01/100 (ISO 1101)		
Seals, recommended fluid temperature	HNBR seals (standard) = -40°C ÷ +60°C, with HFC hydraulic fluids = -40°C ÷ +50°C FKM seals (/PE option) = -20°C ÷ +80°C		
Recommended viscosity	15 ÷ 100 mm ² /s - max allowed range 2.8 ÷ 500 mm ² /s		
Fluid contamination class	ISO 4406 class 21/19/16 NAS 1638 class 10, in line filters of 25 µm (β10 ≥75 recommended)		
Hydraulic fluid	Suitable seals type	Classification	Ref. Standard
Mineral oils	HNBR, FKM	HL, HLP, HLPD, HVLP, HVLPD	DIN 51524
Flame resistant without water	FKM	HFDD, HFDR	ISO 12922
Flame resistant with water	HNBR	HFC	

5 cULus CERTIFICATION

cULus marking

- Class I** = Equipment for famable gas and vapours
- Division 1** = Possibility of explosive atmosphere during normal functioning
- Groups C&D** = Gas group (according to UL 1002)
- Groups IIA&IIB** = Gas group (according to NEC 505-7)
- T4** = Temperature class of solenoid surface referred to +70°C ambient temperature

EXAMPLE OF NAMEPLATE MARKING

MODEL CODE	<input type="text"/>	  <small>LISTED 48AM</small> Solenoid for use in hazardous locations
SERIAL N°	<input type="text"/>	
Class I, Groups C & D		Temperature code <input type="text"/>
<input type="radio"/> Max ambient temp. 70° C 158° F <input type="radio"/>		
Electrical rating: <input type="text"/>		
CAUTION: To reduce the risk of ignition of hazardous atmospheres, disconnect from circuit before opening enclosure. Keep tightly closed when in operation.		
T-576/BT		

Notified body and certificate number _____

Marking according to UL Directive _____

8 POPPET TYPE LEAK FREE DIRECTIONAL SOLENOID VALVES: MODEL CODE

<p style="text-align: center;">DLAH</p> <p>DLAH = direct (10 l/min) DLAHM = direct (25 l/min) DLHP = hydraulic operated DLAHP = solenoid piloted DLP = hydraulic operated DLAP = solenoid piloted</p> <p>X = Stainless steel execution for all parts XS = Stainless steel execution for external parts</p> <p>Temperature class (not for DLHP and DLP) see sect. 1 4 = T4 6 = T6</p> <p>Certification type - = omit for Multicertification /UL = cULus with 1 m cables lenght, factory wired</p> <p>3 = three way</p> <p>Valve configuration, see section 8.1 A = A (B) to T in rest position C = P to A (B) in rest position</p>	X	6	*	-	3	A	/	M	/	V	24DC	**	/	*	/	*
---	----------	----------	----------	----------	----------	----------	----------	----------	----------	----------	-------------	-----------	----------	----------	----------	----------

Options: (not for DLHP, DLP)
R = solenoid manual reset (not combinable with /V)
V = handwheel manual override (not combinable with /R)
O = Horizontal cable entrance

Only for DLAP
D = internal drain
E = external pilot pressure

Solenoid threaded connection for cable gland:
M = M20x1,5 UNI-4535 (6H/6g) for **Multicertification**
NPT = 1/2" NPT ANSI B2.1 (tapered) for **/UL**

8.1 Hydraulic configuration

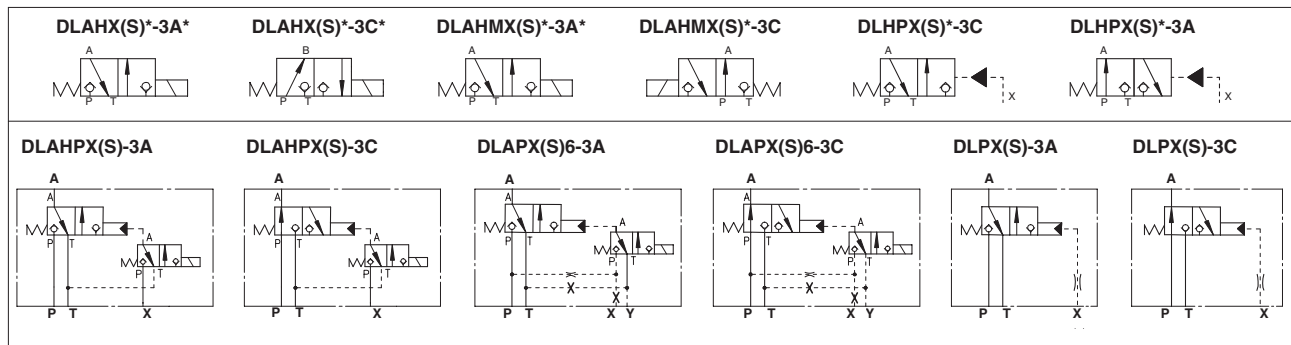

9 PRESSURE CONTROL VALVES: MODEL CODE

9.1 Screw-in type

<p style="text-align: center;">CART</p> <p>Screw-in relief cartridge</p> <p>See note (1): MX(S)-3 = G1/2 MX(S)-6 = M33x1,5 AREX(S)-20 = M35x1,5</p> <p>Pressure range: see hydraulic characteristics in table below</p>	MX-3	/	350	/	*	/	*	/	**	/	*	/	*
---	-------------	----------	------------	----------	----------	----------	----------	----------	-----------	----------	----------	----------	----------

Seals material, see section 4:
 - = HNBR
PE = FKM

Series number

Test fluid, only for X execution:
H = mineral oil
W = pure water

Options
PED = reduced leakages and certified according to 2014/68/UE

Only for PED
 * = factory preset regulation to be defined depending to the customer requirements
 min step: 1bar - min pressure setting: 25 bar
 (example 280 = 280 bar)

(1): **X** = Stainless steel execution for all parts
XS = Stainless steel execution for external parts

Hydraulic characteristics

Valve model	CART MX(S)-3	CART MX(S)-3/PED	CART MX(S)-6	CART MX(S)-6/PED	CART AREX(S)-20	CART AREX(S)-20/PED
Max pressure setting [bar]	/50 /100 /210 /350 /420	/50 /100 /210 /350	/50 /100 /210 /350 /420	/100 /210 /350	/50 /100 /210 /315 /400	/100 /210 /315 /400
Pressure range [bar] (1)	2÷50 6÷100 7÷210 8÷350 15÷420	25÷50 25÷100 25÷210 25÷350	2÷50 3÷100 8÷210 15÷350 15÷420	25÷100 100÷210 210÷350	3÷50 5÷100 6÷210 8÷315 10÷400	25÷100 100÷210 210÷315 315÷400
Max flow [l/min]	2,5	2,5	40	60	120	150

(1) The values correspond to the min and max regulation of the valve's craking pressure.

9.2 Modular type

HMP	X	-	011	/	350	**	/	*	/	*
Modular pressure relief valve ISO 4401 size 06						Series number		Seals material, see section 4: - = HNBR PE = FKM		Test fluid, only for X execution: H = mineral oil W = pure water
X = Stainless steel execution for all parts XS = Stainless steel execution for external parts										
Configuration, see section 9.5 011 013 014										
					Pressure range for HMP: 50 = 50 bar 100 = 100 bar			210 = 210 bar 350 = 350 bar		

9.3 Control cover

LIMM	X	-	2	/	350	**	/	*	/	*
Cover according to ISO 7368						Series number		Seals material, see section 4: - = HNBR PE = FKM		Test fluid, only for X execution: H = mineral oil W = pure water
X = Stainless steel execution for all parts XS = Stainless steel execution for external parts										
Size: 2 = 25					Pressure range 50 = 6 ÷ 50 bar 100 = 8 ÷ 100 bar			210 = 10 ÷ 210 bar 350 = 15 ÷ 350 bar		

9.4 Standard cartridge valve to be coupled with LIMMX(S) cover

SC LI	X	-	25	31	/	2	**	/	*	/	*
Cartridge according to ISO 7368							Series number		Seals material, see section 4: - = HNBR PE = FKM		Test fluid, only for X execution: H = mineral oil W = pure water
X = Stainless steel execution for all parts											
Size 25						Spring cracking pressure 1 = 0,3 bar 2 = 1,2 bar			3 = 3 bar 6 = 6 bar		
Area ratio 1÷1											
Note: for LIMMXS cover, the standard SCLI-25* cartridge can be used											

9.5 Hydraulic configuration

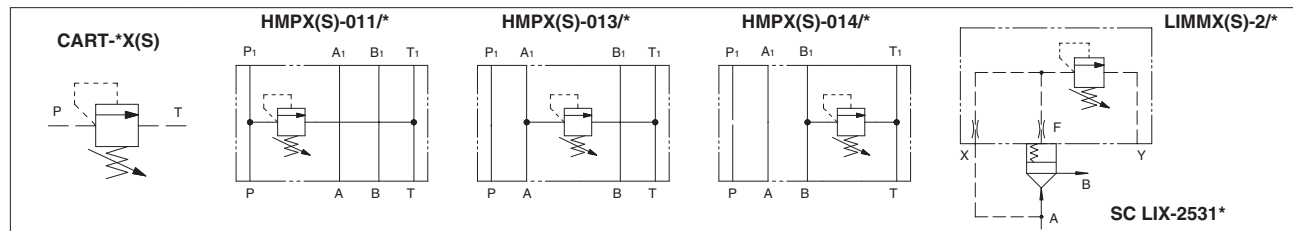

10 CABLE GLANDS AND WIRING

10.1 Cable glands - only for Multicertification

Cable glands with threaded connections M20x1,5 for standard or armoured cables have to be ordered separately, see tech. table **K600**

10.2 Terminal board and solenoid wiring

Terminal board for Multicertification

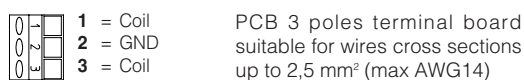

Solenoid wiring cULus certification



10.3 Wiring specifications

Power supply: section of coil connection wires = 2,5 mm² for **Multicertification** 1,2 mm² for **cULus** certification

Grounding: section of internal ground wire = 2,5 mm² for **Multicertification** 1,2 mm² for **cULus** certification

Only for Multicertification the additional equipotential grounding can be also performed by the user on the external facility provided on the solenoid case. Section of external ground wire = 4 mm²

For Multicertification the cable must be suitable for the working temperature as specified in the "safety instructions" delivered with the first supply of the products.

Max ambient temperature [°C]	Temperature class	Surface temperature [°C]	Cable temperature
45 °C	T6	85 °C	not prescribed
70 °C	T4	135 °C	90 °C

11 Q/Δp DIAGRAMS (based on mineral oil ISO VG 46 at 50°C)

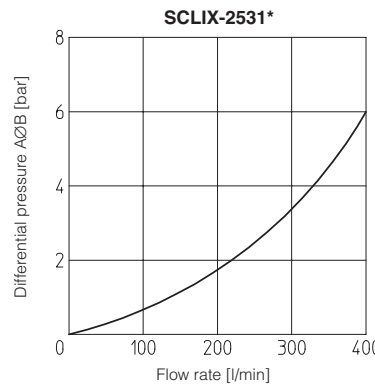
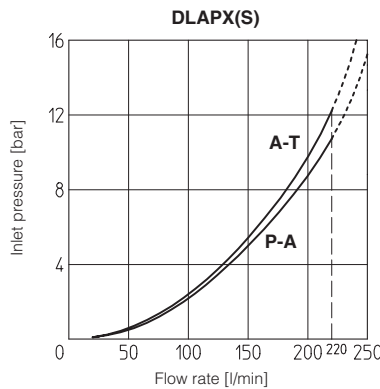
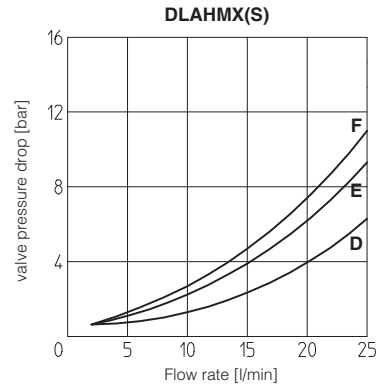
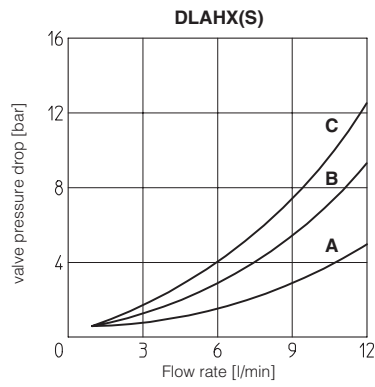
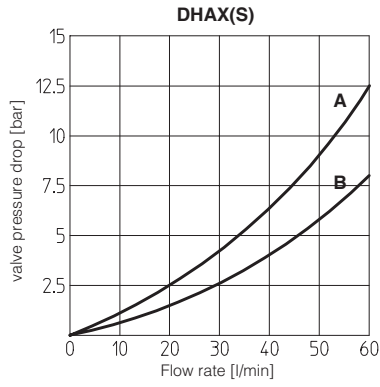

DHAX(S)

Spool type	Flow direction				
	P→A	P→B	A→T	B→T	P→T
0	B	B	B	B	A
1, 1/2	A	A	A	A	
3	A	A	B	B	
6	A	A	B	A	
7	A	A	A	B	

Valve type	Flow direction	
	P → A (P → B)	A → T (B → T)
DLAHX(S)-3A	C	B
DLAHX(S)-3C	B	A
DLAHMX(S)-3A	F	E
DLAHMX(S)-3C	E	D

12 OPERATING LIMITS OF ON/OFF DIRECTIONAL CONTROLS (based on mineral oil ISO VG 46 at 50°C)

The diagram have been obtained with warm solenoids and power supply at lowest value ($V_{nom}=10\%$). For DHAX(S) valves the curves refer to application with symmetrical flow through the valve (i.e. P → A and B → T). In case of asymmetric flow the operating limits must be reduced.

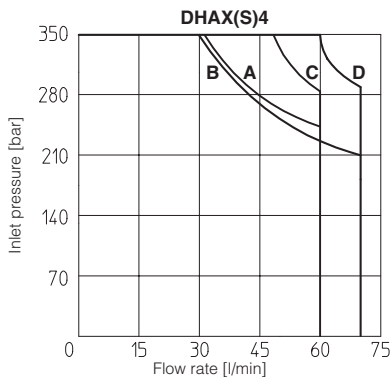

DHAX4 A = Spools 0,1 B = Spools 1/2, 3, 6, 7
DHAXS4 C = Spools 0,1 D = Spools 1/2, 3, 6, 7

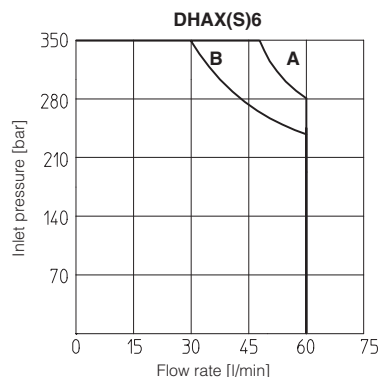

A = Spools 0,1 B = Spools 1/2, 3, 6, 7

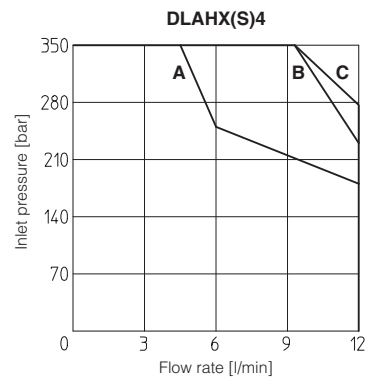

DLAHX4 A = Spool 3C B = Spool 3A
DLAHXS4 C = Spools 3C, 3A

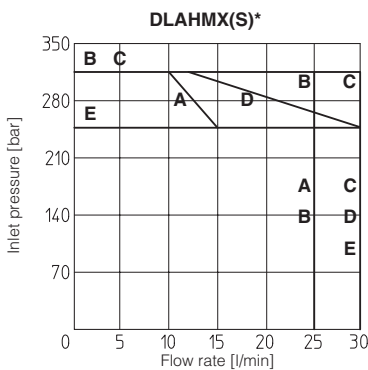

DLAHMX4 A = Spool 3C B = Spool 3A
DLAHMXS4 C = Spool 3A D = Spool 3C
DLAHMXS6 E = Spool 3A, 3C

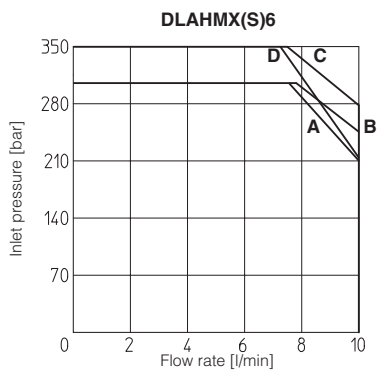

DLAHX6 A = Spool 3A B = Spool 3C
DLAHXS6 C = Spool 3A D = Spool 3C

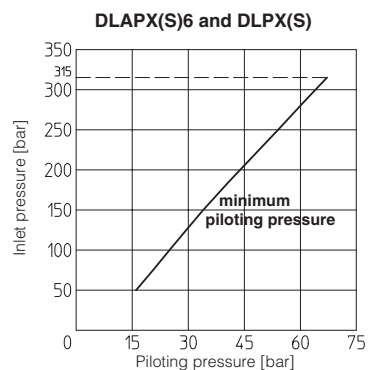

12.1 Internal leakages for DLAHX(S), DLAHM(S), DLAHPX(S), DLHPX(S), DLAPX(S) and DLPX(S): less than 5 drops/min (0,36 cm³/min) at max pressure.

12.2 Piloting pressure for DLAHPX(S) and DLHPX(S) max piloting pressure = 315 bar; min piloting pressure = 90 bar
for DLAPX(S) and DLPX(S) max piloting pressure = 315 bar; min piloting pressure = see above diagram

13 REGULATED PRESSURE VERSUS FLOW DIAGRAM of screw-in cartridge valves (based on mineral oil ISO VG 46 at 50°C)

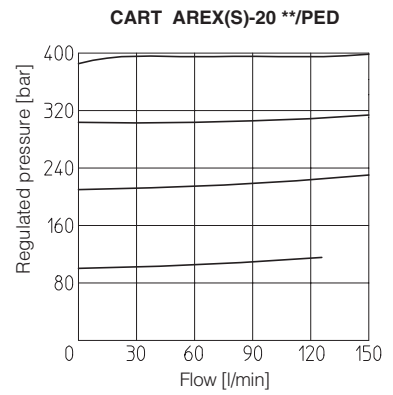
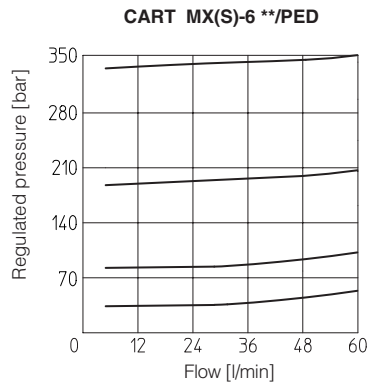
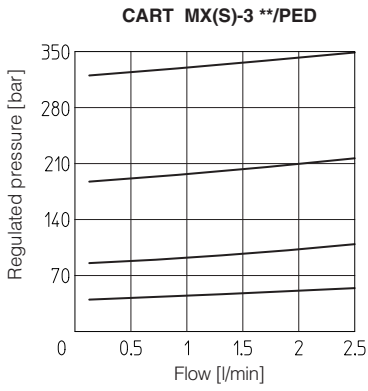
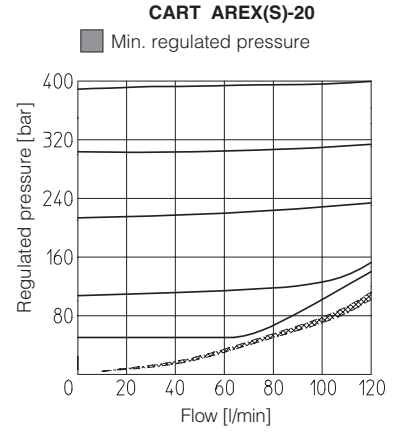
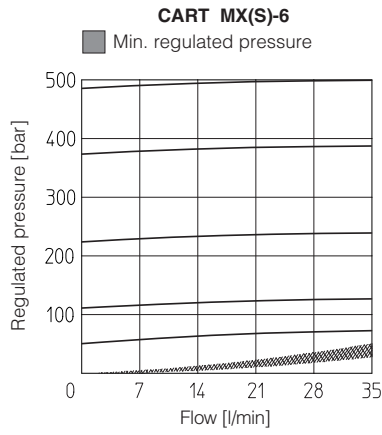
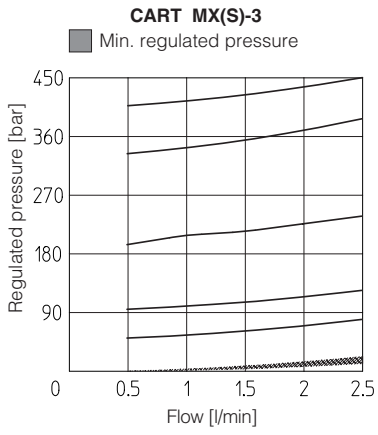

14 PERMITTED WORKING RANGES of screw-in cartridge valves with PED option (shared area)

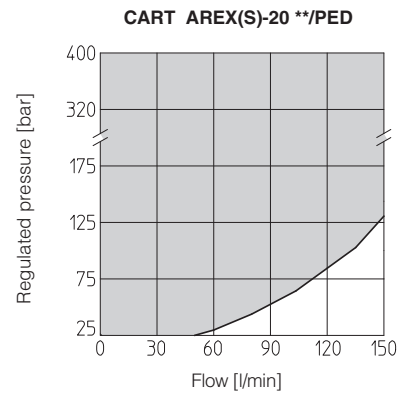
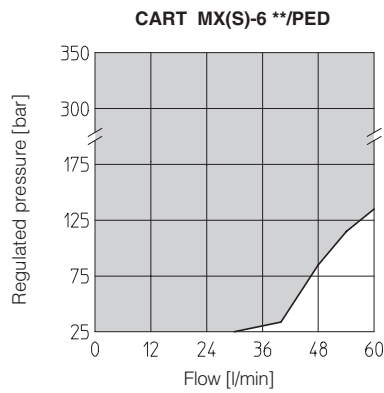
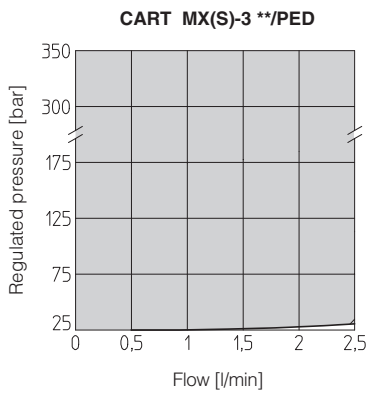

14.1 Regulated pressure for modular valves

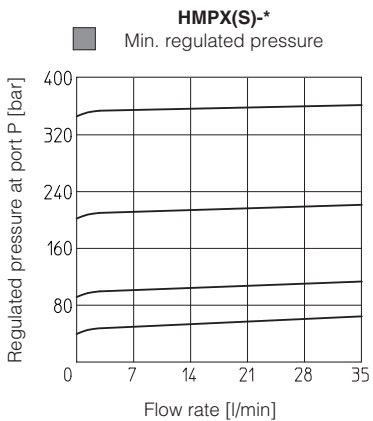

15 INSTALLATION DIMENSIONS OF DHAX(S) [mm]

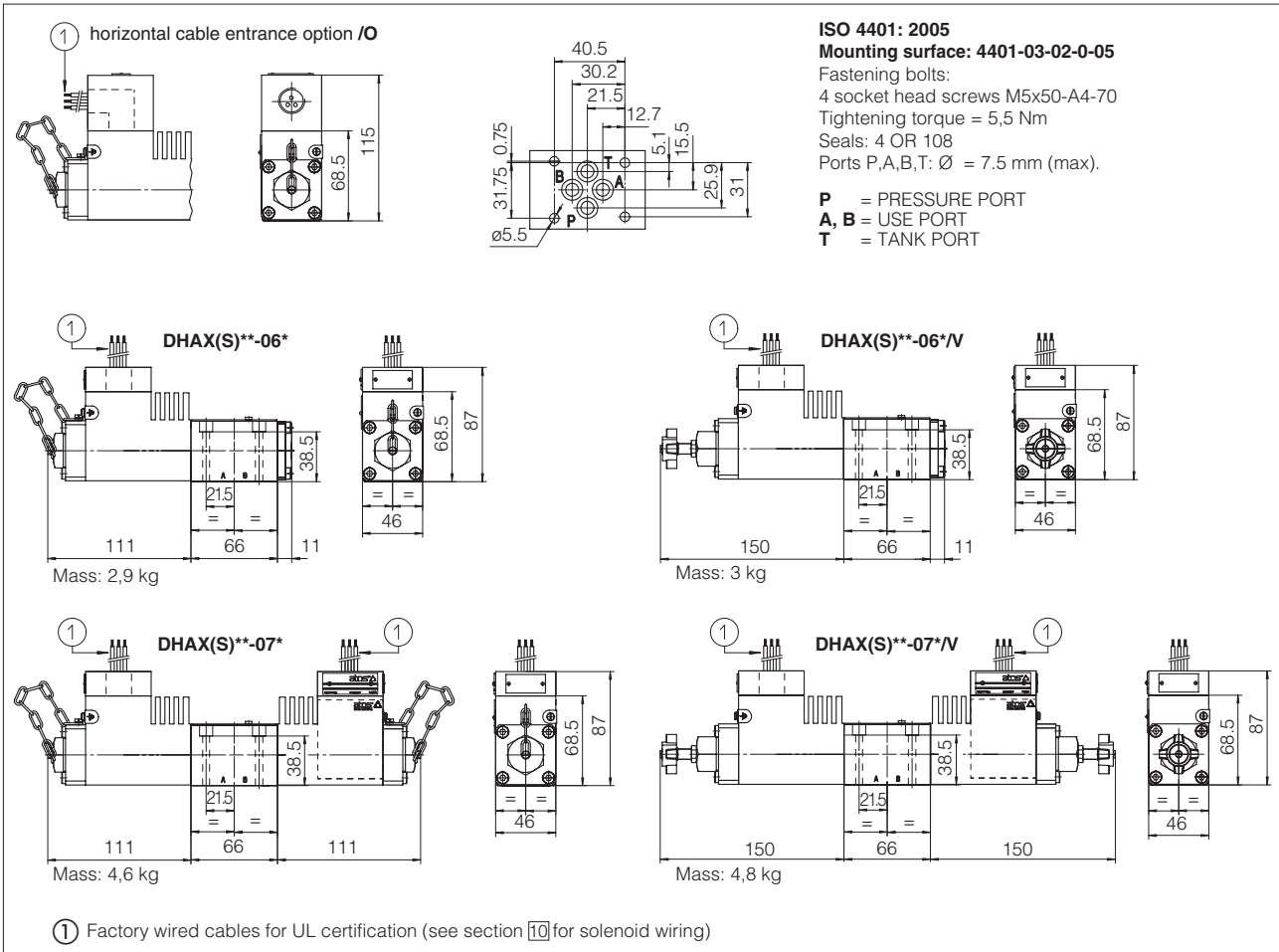

16 INSTALLATION DIMENSIONS OF DLAHX(S) AND DLAHMX(S) [mm]

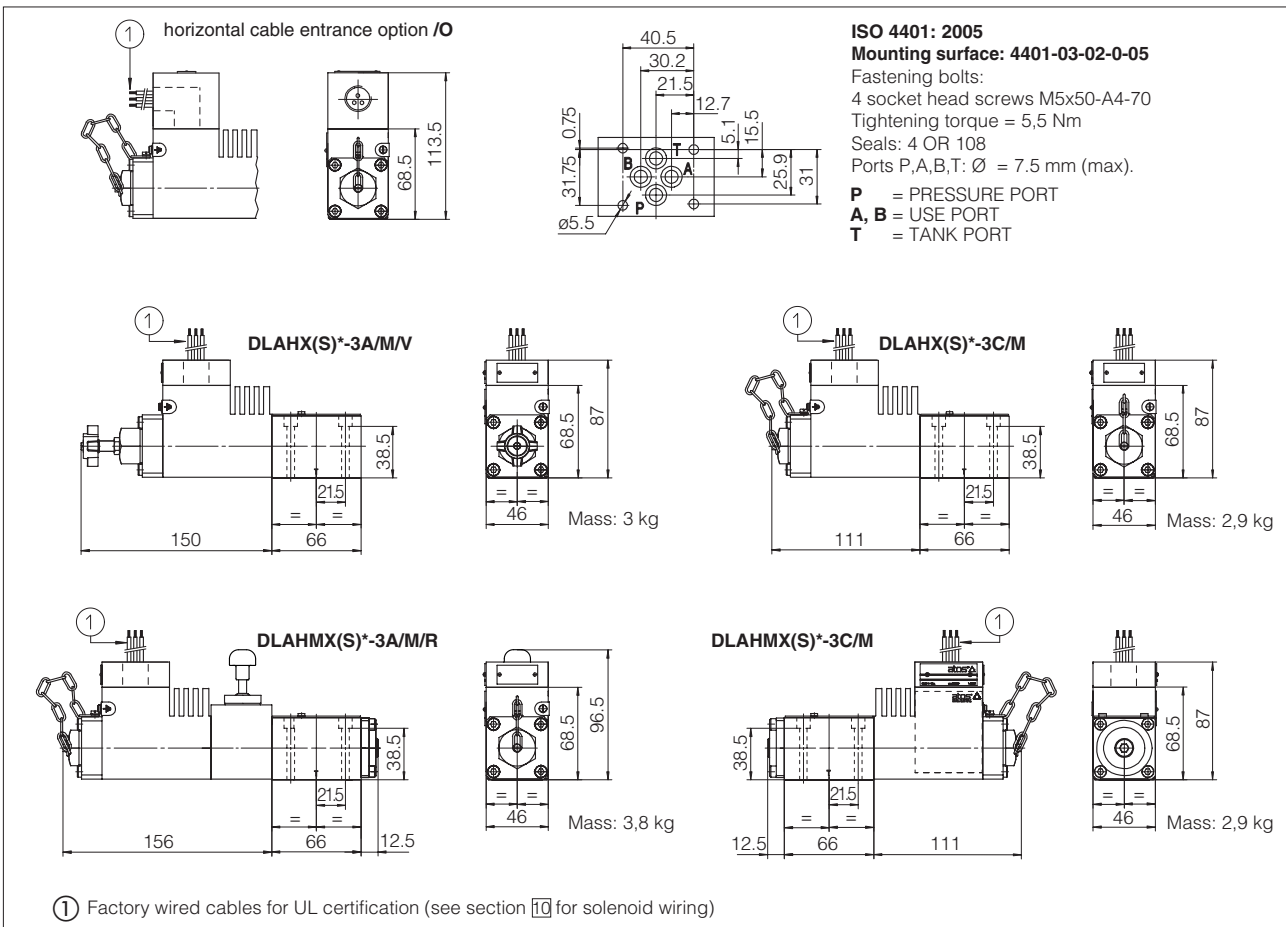

17 INSTALLATION DIMENSIONS OF DLHPX(S) AND DLAHPX(S) [mm]

ISO 4401: 2005

Mounting surface: 4401-03-02-0-05

Fastening bolts:

4 socket head screws M5x75-A4-70

Tightening torque = 5,5 Nm

Seals: 4 OR 108

Ports P,A,B,T: Ø = 7.5 mm (max).

P = PRESSURE PORT
A = USE PORT
B = not present
T = TANK PORT
X = PILOT PORT

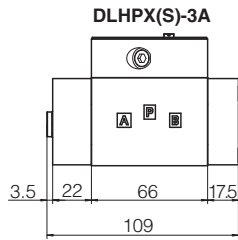
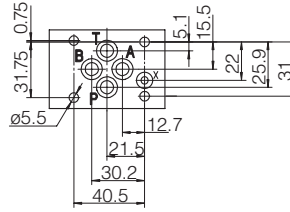

Mass: 5 kg

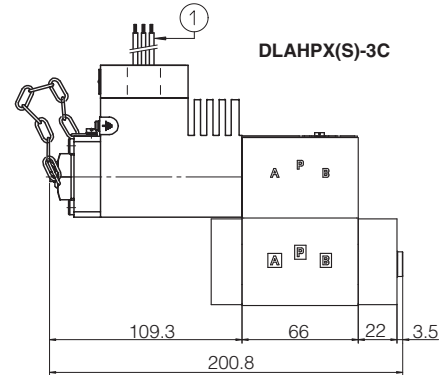
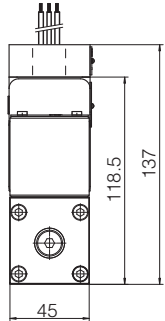
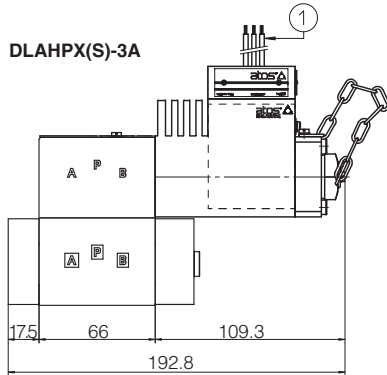
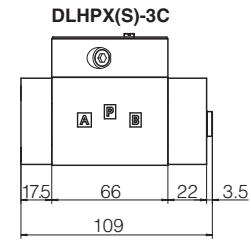
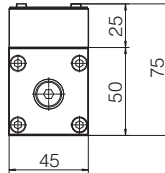

① Factory wired cables for UL certification (see section 10 for solenoid wiring)

18 INSTALLATION DIMENSIONS OF DLAPX(S) AND DLPX(S) [mm]

Mounting surface DLAPX(S)6 and DLPX(S)
not ISO standard

Fastening bolts:

4 socket head screws M10x70-A4-70

Tightening torque = 40 Nm

Seals: 3 OR 3081; 2 OR 108

Ports P,A,T: Ø = 16 mm (max)

Ports X, Y: Ø = 7 mm (max)

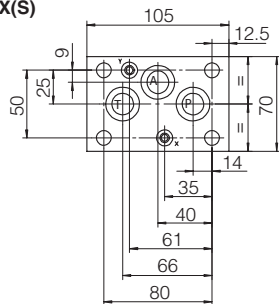

DLAPX(S)6-3A/M
DLAPX(S)6-3C/M (dotted line)

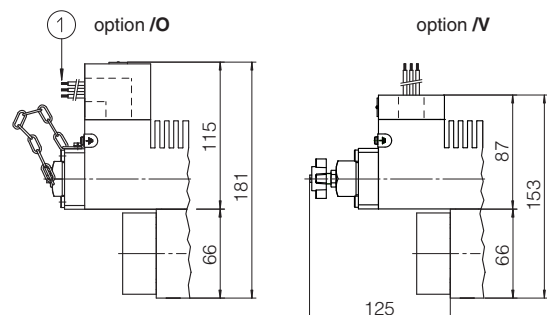
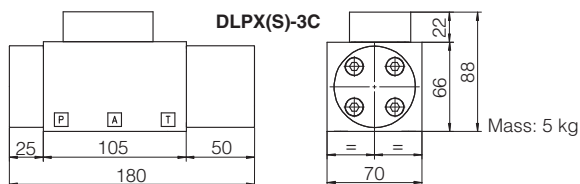
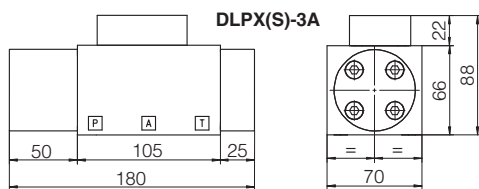
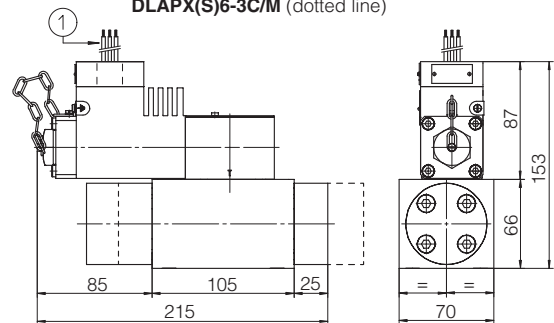

① Factory wired cables for UL certification (see section 10 for solenoid wiring)

19 INSTALLATION DIMENSIONS OF SCREW IN PRESSURE RELIEF VALVES [mm]

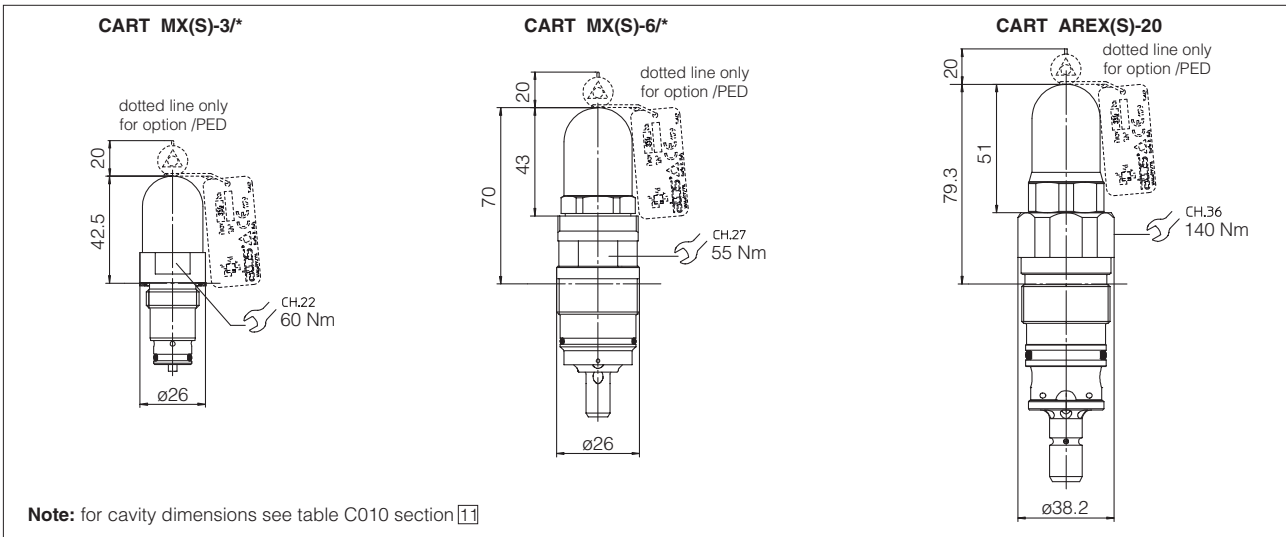

20 INSTALLATION DIMENSIONS OF MODULAR AND CARTRIDGE VALVES

ISO 4401: 2005
Mounting surface: 4401-03-02-0-05
 Fastening bolts: M5x**-A4-70
 Tightening torque = 5,5 Nm
 Seals: 4 OR 108
 Ports P,A,B,T: $\phi = 7.5$ mm (max)

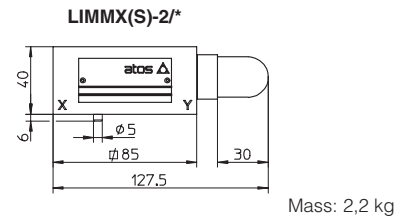
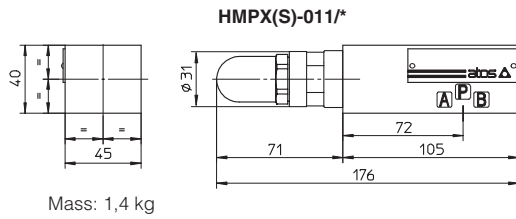
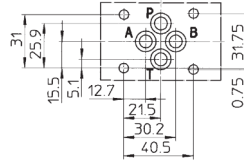

Cover interface dimensions for LIMMX(S)-2

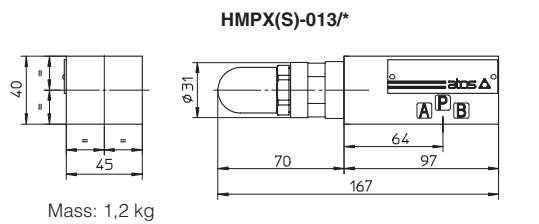
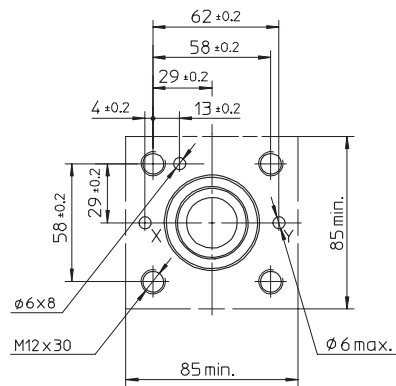

Recess dimensions for SC LIX-25

