

# Damping rings

These vulcanized components consist of two aluminium rings embedded in oil-resistant rubber, which guarantee superior mechanical strength and are particularly suitable for vertically mounted motor-and-pump units.

Positioned between the bell-housing motor flange and the lid of the tank lid, they help to reduce the transmission of vibrations and the emission of noise generated by the system.

Damping rings provide a perfect hydraulic sealing actions by virtue of their special profile, which resembles an O-ring surrounded by a flange with fixing holes.

Rings are available for a range of motors from size 80, rated 0.5 kW, up to size 180 rated 22 kW.

The noise level of the motor-pump unit can be reduced by as much as 5 Db (A).

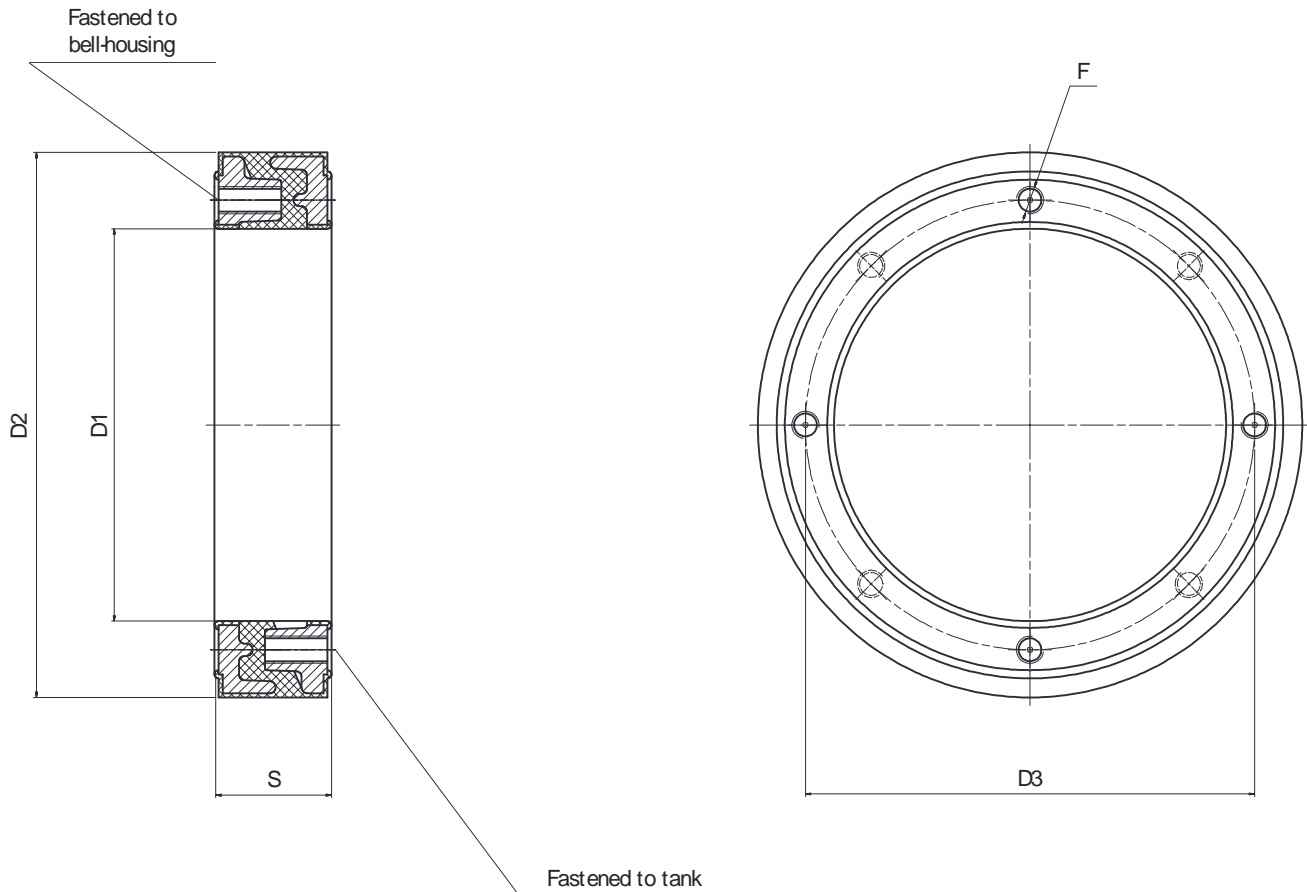

TABLE 47

Foot bracket	D1	D2	D3	S	F	Weight (kg)
ANM A 200	146	200	165	43	M10 (profondità: 16 mm)	1,70
ANM A 250	190	250	215	48	M12 (profondità: 16 mm)	2,53
ANM A 300	239	300	265	53	M12 (profondità: 16 mm)	2,15
ANM A 350	260	350	300	62	M16 (profondità: 20 mm)	3,95

Note: For dimensions other than those indicated in the table, contact the MP Filtri Technical and Sales Department.