

6.3.1 TECHNICAL DATA

MAX OPERATING PRESSURE (PS): 4000 PSI

PRESSURE TEST (PT): 1.5 x PS

NOMINAL CAPACITIES: 1/4 - 1 - 2.5 - 5 - 10 - 15 gallons

WORKING TEMPERATURE: -40 ÷ +200 °F (-40 ÷ +93 °C)

BODY MATERIAL:

- carbon steel shell (SA 372 grade E class 70)
painted with rust inhibitor RAL 8012
- nickel coating 25 - 40 μ
- internal and external coating with RILSAN th. 0.6 mm

VALVES MATERIAL:-

- phosphated or
- galvanized carbon steel in compliance with Directive 2002/95/EC (RoHS) to resist to corrosion
- stainless steel AISI 316L
- nickel coating 25-40 μ

SEALS MATERIAL:-

- **P** = Nitrile rubber (NBR)
- **F** = Low temp. nitrile rubber
- **H** = Nitrile for hydrocarbons
- **K** = Hydrogenated nitrile (HNBR)
- **B** = Butyl (IIR)
- **E** = Ethylene-propylene (EPDM)
- **N** = Chloroprene (Neoprene)
- **Y** = Epichlorohydrin (ECO)
- **V** = Fluorocarbon (FKM)

See Table 3.1c and/or Chapter 6.2.5

CONNECTIONS: see Table 6.2db - 6.2dc - 6.2df

WEIGHT: see Table 6.2db - 6.2df

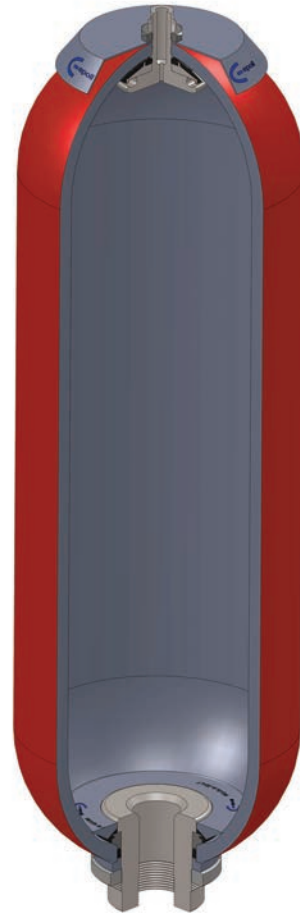

6.3a

6.3.2 DESCRIPTION

Additional bottles type ASSA consist of a seamless cylindrical pressure vessel made of high-tensile steel.

They are derived from the same shells of the bladder accumulator type ASSA.

The additional bottles are used to take in and store nitrogen to increase the gas volume in the accumulator station (with bladder or piston accumulator). This means that smaller accumulators can be used for the same gas volume and costs can be reduced. EPE offers a wide selection of bottles type, such as forged "B" version, shell of bladder accumulator "ASS" and "ASSA" versions or body piston type "AB" version.

6.3.4 HYDRAULIC SYMBOL

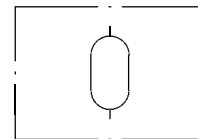

6.3b

6.3.3 "ASSA" ADDITIONAL CYLINDERS ADVANTAGES

- compact
- simple construction
- wide range of small-medium capacity
- works well on water, low lubricity fluids
- quick, easy installation

6.3.5 SEALS-TEMPERATURE-LIQUID COMPATIBILITY

When selecting the additional cylinder variant, pay attention to the following non-binding notes with regard to hydraulic fluid, seals material and the permissive temperature range. (see Section)

Code letter	Polymer	ISO	Temperature range (°C)	Some of the liquids compatible with the polymer
P	Standard nitrile (Perburan)	NBR	-20 ÷ +80	Aliphatic hydrocarbons (propane, butane, gasoline, oils, mineral greases, diesel fuel, fuel oil, kerosene), mineral greases and oils, HFA - HFB - HFC fluids, many dilute acids, alkalis, saline solutions, water, water glycol.
F	Low temperature nitrile	NBR	-40 ÷ +70	The same as with standard nitrile + a number of different types of Freon. (This contains less acrylonitrile than the standard and is therefore more suitable for low temperatures, but its chemical resistance is slightly lower).
H	Nitrile for hydrocarbons	NBR	-10 ÷ +90	Regular and premium grade slightly aromatic gasoline (and all the liquids for standard nitrile).
K	Hydrogenated nitrile	HNBR	-30 ÷ +130	The same as with standard nitrile but with excellent performance at high and low temperatures.
B	Butyl	IIR	-30 ÷ +100	Hot water up to 100°C, glycol-based brake fluids, many acids and bases, salt solutions, polar solvents such as alcohols, ketones and esters, polyglycol-based hydraulic fluids (HFC fluids) and bases of esters of phosphoric acid (HFD-R fluids), silicone oils and greases, resistance to ozone, aging and weathering.
E	Ethylene-Propylene	EPDM	-30 ÷ +100	Hot water up to 100°C, glycol-based brake fluids, many organic and inorganic acids, detergents, solutions of sodium and potassium, phosphate ester-based hydraulic fluids, (HFD-R), silicone oils and greases, many polar solvents (alcohol, ketones, esters), Skydrol LD4 and 500B-4, resistance to ozone, aging and weathering.
N	Chloroprene (Neoprene)	CR	-30 ÷ +100	Mineral oils of paraffin, silicone oils and greases, water and aqueous solutions, refrigerants (ammonia, carbon dioxide, Freon), naphthenic mineral oils, low molecular aliphatic hydrocarbons (propane, butane, fuel), brake fluids based on glycol, better resistance to ozone, weathering and aging compared to NBR rubber.
Y	Epichloridrin	ECO	-30 ÷ +110	Mineral oils and greases, aliphatic hydrocarbons (propane, butane and gasoline), silicone oils and greases, water at room temperature, resistance to ozone, aging and weathering.
V	Fluorocarbon	FKM	-10 ÷ +150	Mineral oils and greases, non-flammable fluids of HFD group, silicone oils and greases, animal and vegetable oils and greases, aliphatic hydrocarbons (gasoline, butane, propane, natural gas), aromatics hydrocarbons (benzene, toluene), chlorinated hydrocarbons (Tetrachloroethylene, carbon tetrachloride), fuel (regular, super and containing methanol), excellent resistance to ozone, weathering and aging.

For other hydraulic fluid and/or temperatures, please consult us.

6.3c

6.3.6 ORDER CODE

1	2	3	4	5	6	7	8	9	
ASSA	5	P	4000	C	H	8	VT	-	7

1	Series
Additional bottle with ASME U-Stamp = ASSA	

2	Nominal capacity (gallons)
1/4 (0.95 l) = 1/4	
1 (3.78 l) = 1	
2.5 (9.46 l) = 2.5	
5 (18.93 l) = 5	
10 (37.85 l) = 10	
15 (56.78 l) = 15	

3	Seals material material
Nitrile rubber (NBR)	= P
Nitrile for low temp.	= F
Nitril for hydrocarbons	= H
Hydrogenated nitrile (HNBR)	= K
Butyl (IIR)	= B
Ethylene-propylene (EPDM)	= E
Chloroprene (Neoprene)	= N
Epichlorohydrin (ECO)	= Y
Fluorocarbon (FKM)	= V

4	Max working pressure (PS)
4000 PSI (275 bar) = 4000 (3000 only for the version with connection L)	

5	Body material
Carbon steel	= C
Nickel coated carbon steel 25 μ	= N
Nickel coated carbon steel 40 μ	= M
Rilsan coating	= V

9	Testing and certification
ASME U-STAMP (ASME VIII div.1 appendix 22) = 7	
Australian standard = 2	
Dosh = 20	

8	Top connection
Thread hole M12x1.5 plugged = VT	
1/4" BSP ISO 228 = G2	
1/2" BSP ISO 228 = G4	
3/4" BSP ISO 228 = G5	
1" BSP ISO 228 = G6	
1"1/4 BSP ISO 228 = G7	
1"1/2 BSP ISO 228 = G8	

7	Bottom connection dimension
For the type of connection:	
G 3/4" BSP ISO 228 = 5	
1" BSP ISO 228 = 6	
1"1/4 BSP ISO 228 = 7	
1"1/2 BSP ISO 228 = 8	
2" BSP ISO 228 = 9	
L (3÷5 l) 1" 1/4 SAE3000 = 7	
(10÷55 l) 1" 1/2 SAE 3000 = 8	
2" SAE 3000 = 9	
H (3÷5 l) 1" 1/4 SAE6000 = 7	
(10÷55 l) 1" 1/2 SAE 6000 = 8	
2" SAE 6000 = 9	
(1/4 gallon) 1"1/16 12UN = 1 1/16-12	
(1 gallon) 1"5/8 12UN = 1 5/8-12	
(2.5÷15 gallons) 1"7/8 12UN = 1 7/8-12	
Special variants upon request	

6	Bottom connection
BSP ISO 228 = G	
BSP ISO 228 with chamfer for OR = A	
adapter for flange SAE 3000 Psi = L	
adapter for flange SAE 6000 Psi = H	
SAE connection = S	

6.3.7 DIMENSIONS

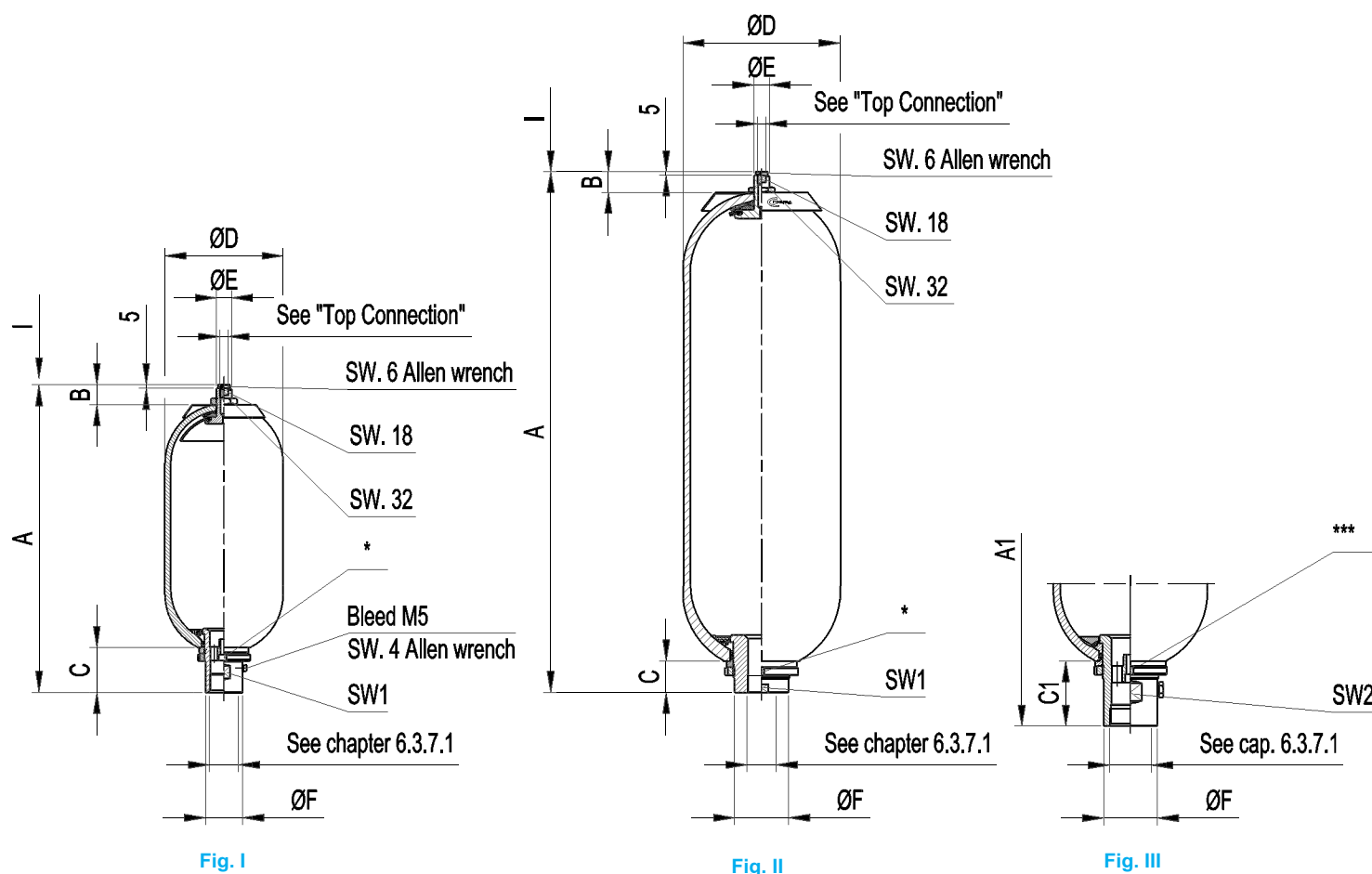

Fig. I

Fig. II

Fig. III

Acc. type ASSA in carbon steel	Nominal gas volume gallons	Effective gas volume litres	Working pressure bar	Max.diff. pressure P2-P1 psi	Flow rate l/min	Max.comp. ratio P0/P2	Fig.	A mm	A1** mm	B mm	C mm	C1** mm	Ø D mm	Ø E mm	ØF mm	I mm	SW 1 mm	Acc. dry weight kg
ASSA 1/4	1/4	1	4000	1450	300	1:4	I	261 ± 5	-	15	52	-	114	M22x1.5	36	140	32	11
ASSA 1	1	3,5	4000	1450	600	1:4	I	364 ± 10	-	20	65	-	168	M22x1.5	53	140	50	21
ASSA 2,5	2,5	9,1	4000	1450	1000	1:4	II-III	471 ± 10	527 ± 10	30	45	93	223	M22x1.5	77	140	70	35
ASSA 5	5	18,2	4000	1450	1000	1:4	II-III	775 ± 10	831 ± 10	30	45	93	223	M22x1.5	77	140	70	55
ASSA 10	10	33,5	4000	1450	1000	1:4	II-III	1309 ± 10	1365 ± 10	30	45	93	223	M22x1.5	77	140	70	91
ASSA 15	15	50	4000	1450	1000	1:4	II-III	1830 ± 10	1886 ± 10	30	45	93	223	M22x1.5	77	140	70	127

* see chapter 6.3.12 table 6.3dj

** Only for connection type "A" see chapter 6.3.7.1

6.3db

-The maximum differential pressure is the maximum allowable difference between the maximum pressure and the minimum working pressure (P2-P1) to have an infinitelife cycle of the accumulator (greater than 2,000,000 cycles).

- Flow rate measured using mineral oil with viscosity of 36 cSt at 50°C and ΔP = 5 bar

6.3.7.1 STANDARD THREAD CONNECTIONS

Dimensions	Connection Type	Accumulator type	Complete spare valve order code	Ød	ØD mm	ØF mm	H mm
		ASSA 1/4"	V 2250-A7-***	1" 1/4 BSP	46	53	25
		ASSA 1	V 2253-A7-***				
		ASSA 2,5 ÷ 15	V 2064-A9-***	2" BSP	63,35	77	28
	G BSP ISO 228	ASSA 2,5 ÷ 15	V 2267-G8-***	1" 1/2 BSP	-	77	25

* Gasket material

** Components material

6.3dc

6.2.3.2 ADAPTER FOR FLANGE SAE 3000/6000 PSI (L/H)

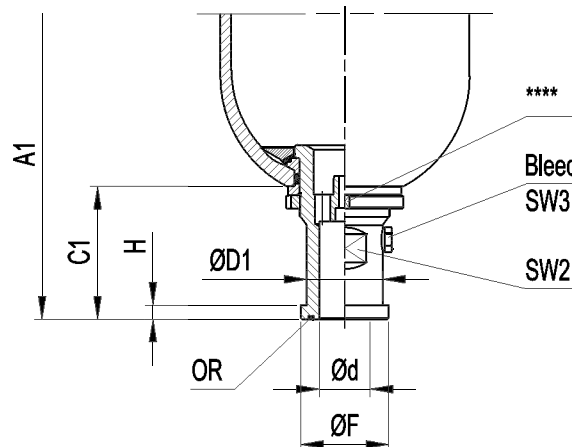

6.3de

Acc. type ASSA in carbon steel	Dim.	A1 mm	C1 mm	SW2 mm	SW3 mm	Bleed	Ød mm	SAE 3000 (L)				SAE6000 (H)				OR	Acc. dry weight kg
								Spare valve order code	ØD1 mm	ØF mm	H mm	Spare valve order code	ØD1 mm	ØF mm	H mm		
ASSA 1/4"	-	-	-	-	-	-	-	-	-	-	-	-	-	-	-	-	
ASSA 1	-	-	-	-	-	-	-	-	-	-	-	-	-	-	-	-	
ASSA 2,5	1"1/2	541± 10	115	42	19****	1/4"	32	V 2064-L8-***	50	60,3	8	V 2064-H8-***	51	63,5	12,5	0010R4187-*	38
	2"						45	V 2064-L9-***	62	71,5	9,5	V 2064-H9-***	67	77,6			
ASSA 5	1"1/2	845 ± 10	115	42	19****	1/4"	32	V 2064-L8-***	50	60,3	8	V 2064-H8-***	51	63,5	12,5	0010R4187-*	58
	2"						45	V 2064-L9-***	62	71,5	9,5	V 2064-H9-***	67	77,6			
ASSA 10	1"1/2	1379± 10	115	42	19****	1/4"	32	V 2064-L8-***	50	60,3	8	V 2064-H8-***	51	63,5	12,5	0010R4187-*	94
	2"						45	V 2064-L9-***	62	71,5	9,5	V 2064-H9-***	67	77,6			
ASSA 15	1"1/2	1900± 10	115	42	19****	1/4"	32	V 2064-L8-***	50	60,3	8	V 2064-H8-***	51	63,5	12,5	0010R4187-*	130
	2"						45	V 2064-L9-***	62	71,5	9,5	V 2064-H9-***	67	77,6			

* Gasket material

** Components material

*** Allen wrench

**** Ex. Wrench

***** see chapter 6.3.11 table 6.3dh

6.3df

6.3.8 SPARE PARTS CODE (STANDARD VERSION)

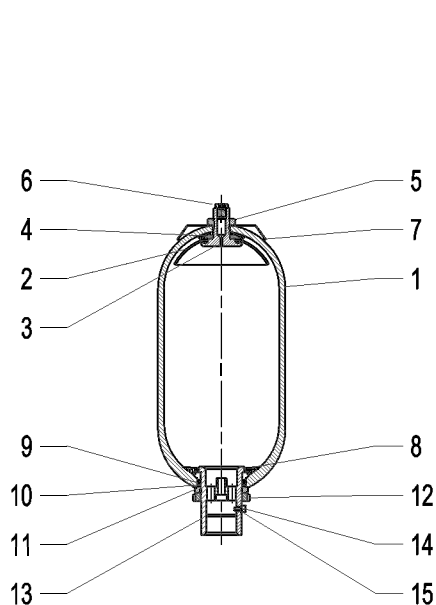

Fig. I

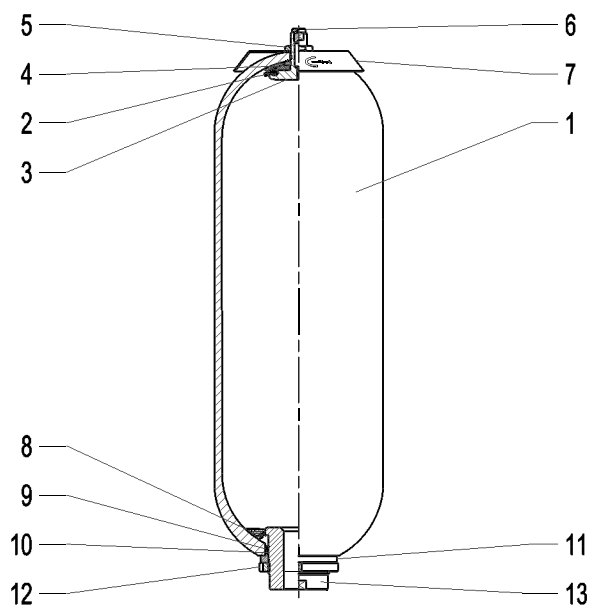

Fig. II

6.3dg

Item	Description	Q.ty	Type		
			ASSA 1/4 (Fig. I)	ASSA 1 (Fig. I)	ASSA 2,5+ 15 (Fig. II)
1	Accumulator shell	1	Not supplied as spare part		
2	Seal gas side	1	B11250 - *	B11252 - *	B10052 - *
3	Gas valve body	1	B10107 - **	B10202 - **	B10333 - **
4	Rubber-coated washer	1	B10106 - ** / *	B10205 - ** / *	B10334 - ** / *
5	Gas valve looknut	1	B10109 - **		B10302 - **
6	Plug	1	B10043 - **		
7	Name plate	1	D10300B-A	D10300C-A	D10300D-A
8	Retaining ring	1	B10146- ** / *	B10222 - ** / *	B10317 - ** / *
9	"O" ring	1	0010R0159 - *	0010R6212 - *	0010R0181 - *
10	Supporting ring	1	B10150-T	B10227-T	B10320-T
11	Space ring	1	B10223 - **		B10319 - **
12	Fluid port ring nut	1	B10217 - **		B10321 - **
13	Fluid port body	1	B10144 - *** - **		B10311 - *** - **
14	Bleed screw ****	1	B10128 - **		-
15	Seal ring ****	1	B10129-R		-
	Standard gas valve ass. (parts 2 + 6)	1	V 2033 - ** / *	V 2049 - ** / *	V 2270 - ** / *
	Standard fluid port ass. (parts 8 ÷ 15)	1	V 2250 - *** - ** / *	V 2253 - *** - ** / *	V 2267 - *** - ** / *
	Gasket sets	1	B2380-1- [*] { B11250- [*] 0010R0159- [*] B10150-T	B2381-1- [*] { B11525- [*] 0010R6212- [*] B10227-T	B2382-1- [*] { B10062- [*] 0010R0181- [*] B10320-T

* Gasket material

** Component material

*** See chapter 6.3.6 table 8 - 9

6.3dh

**** Only for Fig. I

6.3.9 EUROPE MARKET

All the additional bottles are pressure vessels and are subject to the national regulations and directives valid at the place of installation.

For additional bottles type ASSA, every shipping batch is complete of a conformity declaration and instructions of use and. All vessel categories (see Table 6.3d) must be protected by means of a pressure relief valve in accordance with Directive 2014/68/EU.

6.3.10 ACCESSORIES

For support equipment, see section 7

For gas side's safety equipment, see section 8

For pre-loading and charging set, see section 11

For other components, see section 12

06.3.11 COMMISSIONING AND MAINTENANCE

Delivery condition.

Depending on the size and quantity ordered, the additional bottles are shipped in cartons or in cartons on pallets, or wooden boxes upon request. Unless otherwise required, certificates and documentation are provided together with the bottles.

Handling

The original packaging is suitable for handling and storage. Where necessary, you should use suitable lifting equipment to support the weight of the bottles. However protect from impact the packaging and handle it with care.

Storage

During storage in the warehouse, leave the product in its original packaging, keeping it away from heat sources and naked flames. The storage temperature should be between +10 and +40°C.

After six years of storage, it is essential to proceed with the replacement of all elastomeric parts before the commissioning.

Marking on the nameplate of the additional bottle:

The additional bottle will be supplied with the following data stamped on the nameplate:

- Logo, name and country of the manufacturer
- Month/year of production
- Product code
- Serial number
- Maximum PS pressure and PT test pressure in Psi
- Min. and max. TS working temperature in Fahrenheit
- Volume V in gallons
- ASME U-stamp
- Pre-charge pressure in Psi

It is strictly forbidden to:

- weld, rivet, bolt or screw any item of the cylinder shell
- engrave or permanently stamp the surfaces of the cylinder shell and / or carry out other operations that could affect or change the mechanical properties of the cylinder
- use the cylinder as a structural element: it should not be subjected to stresses or loads
- change the data of the nameplate and / or the cylinder without the permission of the manufacturer
- use a (dangerous) fluid of Group 1 with equipment designed and manufactured for fluids of Group 2.

Installation

Before installation, you must perform a visual check to verify that the bottles has not suffered any damage during shipping / handling.

Verify that the requested type matches with what stamped on the nameplate.

We recommend using the additional bottles connected to the accumulator with a suitable safety valve (see Chapter 8). This device provides user and equipment protection against possible damages due to pressure peaks.

The additional bottles type ASSA may be installed in any position from horizontal to vertical (preferably with the connections vertically) and the nameplate must be visible.

Proceed to the assembly so that no abnormal force affects the pipes connected directly or indirectly to the additional bottles, so we recommend the use of supporting components and also fastening (please see Chapter 7) to avoid the transmission of vibrations.

Make sure that the bottle is connected to the hydraulic circuit through suitable connection devices.

Make sure the gas is compatible with the elastomer of the seals.

Check that the max. allowed bottle pressure is equal to or greater than that of the hydraulic circuit and that the temperature during operation is maintained within the range expected.

Make sure the fluid does not contain contaminants.

Maintenance

- Periodically check the pre-charge pressure of the system: after the commissioning, check after 2-3 weeks of operation and if there were no leaks, repeat the operation after 3 months; if the pressure at the same temperature was stable, repeat the test yearly. For heavy-duty applications, check the pre-charge every 6 months.
- Periodically (yearly) carry out a visual inspection of the bottle in order to detect any early signs of deterioration such as corrosion, deformation, etc.
- Comply with the requirements of the regulations concerning the verification of the functionality of the equipment according to the country of installation of the bottle.

Disassembly

If for failure, scheduled check or retest it is necessary to remove the additional bottle from the system, prior to removal, completely discharge the pressure within the circuit.

All additional EPE cylinders of the ASSA series can be repaired.

Repair

It can consist in replacing the seals and/or parts of the valves.

For reasons of functionality and security, it is recommended to use only original spare parts.

Demolition and recycling of the additional cylinder

Before demolition or recycling of the additional cylinder, you should always discharge the internal pressure.

If you needed, proceed decontaminating in relation to the gas/fluid used prior to demolition.

6.3.12 SPANNER WRENCH

Fits all standard size bladder accumulator. It is used to remove or install lock nut on fluid port essembly.

1/4 gal code 2506/58

1 gal code 2506/68

2.5÷15 gal code 2506/105

Dimension

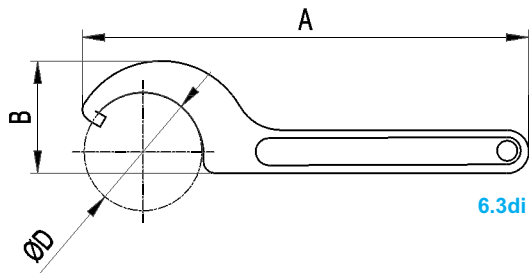

CODE	A	B	ØD	For Accumulator
B2506/58	241	45	58	1/4 gal
B2506/68	241	43	68	1 gal
B2506/105	336	82	105	2.5 ÷ 15 gal

6.3dj

Reproduction Is Forbidden.

In The Spirit Of Continuous Improvement, Our Products May Be Changed.