





HYDRO

Płyty przyłączeniowe *Hydraulic Components*

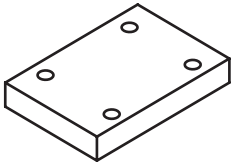
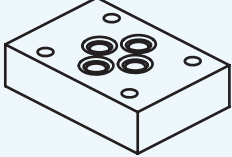
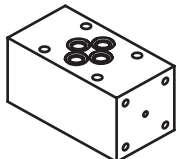

www.hydro.com.pl

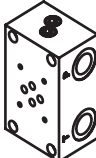
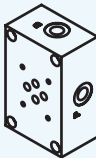
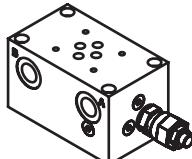
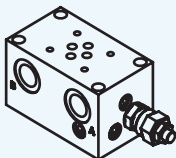
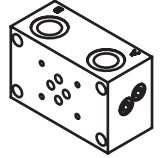
NG6				
MODEL	KOD / CODE	PORT A-B	PORT P-T	STRONA / PAGE
	E_06-00-10	///	///	1
	E_06-00-20	///	///	2
	E_610-06	///	///	3
	E_06-07- _	///	Z DOŁU BACK 1/4 G - 3/8G - 1/2G	4
	E_06-08- _	Z BOKU ON SIDE 1/4G - 3/8G - 1/2G	Z BOKU ON SIDE 1/4G - 3/8G - 1/2G	5
	E_06-09- _	Z BOKU ON SIDE 1/4G - 3/8G - 1/2G	Z BOKU ON SIDE 1/4G - 3/8G - 1/2G	6
	E_06-10-38	Z BOKU ON SIDE 3/8G	Z BOKU - Z DOŁU ON SIDE - BACK 3/8G	7
	E_06-10-12	Z BOKU ON SIDE 1/2G	Z DOŁU BACK 1/2G	8
	E_06-16- _	Z BOKU ON SIDE 1/4G - 3/8G - 1/2G	Z BOKU - Z DOŁU ON SIDE - BACK 1/4G - 3/8G - 1/2G	9

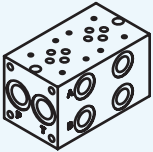
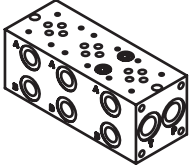
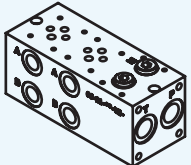
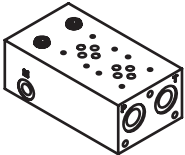
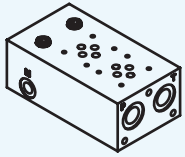
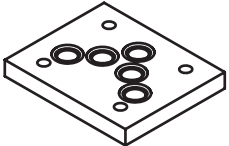
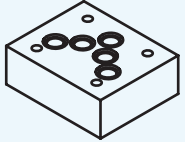
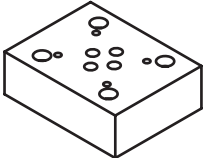
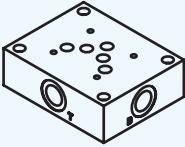

MODEL	KOD / CODE	PORT A - B	PORT P - T	STRONA / PAGE
	E_06 - 12 - 38	Z BOKU <i>ON SIDE</i> 3/8G	Z PRZODU <i>CROSSING</i> 1/2G	10
	E_06 - 14 - 38	Z BOKU <i>ON SIDE</i> 3/8G	Z PRZODU <i>CROSSING</i> 1/2G	11
	E_06 - 21 - 38	Z BOKU <i>ON SIDE</i> 3/8G	Z PRZODU <i>CROSSING</i> 1/2G	13
	E_06 - 13 - 38	Z DOŁU <i>BACK</i> 3/8G	Z PRZODU <i>CROSSING</i> 1/2G	15
	E_06 - 13 - 12	Z DOŁU <i>BACK</i> 3/8G	Z PRZODU <i>CROSSING</i> 1/2G	17
NG10				
MODEL	KOD / CODE	PORT A - B	PORT P - T	STRONA / PAGE
	E_10 - 00 - 10	///	///	19
	E_610 - 10 - _	///	///	20
	E_610 - 05	///	///	21
	E_10 - 02 - _	Z BOKU <i>ON SIDE</i> 1/2G - 3/4G	Z BOKU <i>ON SIDE</i> 1/2G - 3/4G	22

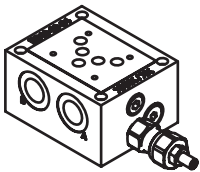
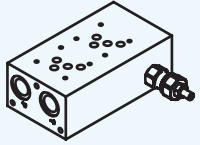
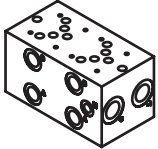
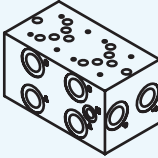
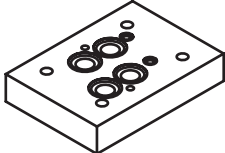
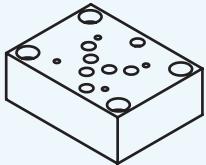
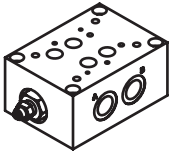

Spis treści

MODEL	KOD / CODE	PORT A - B	PORT P - T	STRONA / PAGE
	E_10-09-__	Z BOKU <i>ON SIDE</i> 1/2G - 3/4G	Z BOKU - Z DOŁU <i>ON SIDE - BACK</i> 1/2G - 3/4G	23
	E_10-05-__	Z DOŁU <i>BACK</i> 1/2G - 3/4G	Z PRZODU <i>CROSSING</i> 3/4G	24
	E_10-06-12	Z BOKU <i>ON SIDE</i> 1/2G	Z PRZODU <i>CROSSING</i> 3/4G	25
	E_10-06-34	Z BOKU <i>ON SIDE</i> 1/2G	Z PRZODU <i>CROSSING</i> 3/4G	27
NG16				
MODEL	KOD / CODE	PORT A - B	PORT P - T	STRONA / PAGE
	E_16-03-30	///	///	29
	E_16-08-00	///	///	30
	E_16-02-__	Z BOKU <i>ON SIDE</i> 3/4G - 1G - 1.1/4G	Z BOKU <i>ON SIDE</i> 3/4G - 1G - 1.1/4G	31



E_06 - 00 - 10

Płyta zaślepiająca NG6 (CETOP 3)

END PLATE CETOP 3

OPIS TECHNICZNY / TECHNICAL DESCRIPTION

SCHEMAT HYDRAULICZNY / HYDRAULIC DIAGRAM

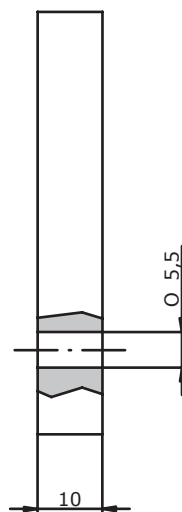
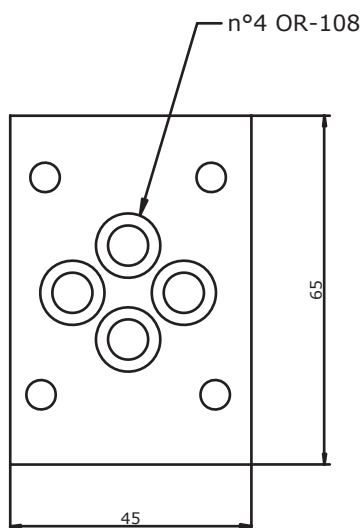
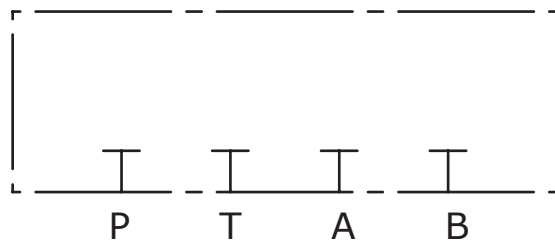
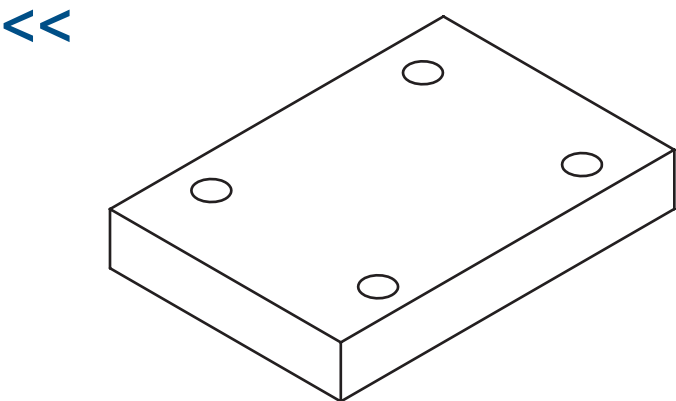

KOD ZAMÓWIENIA - ORDERING CODE

E_06 - 00 - 10

S = STAL / STEEL

E_06 - 00 - 20

Płyta zaślepiająca NG6 (CETOP 3)

END SUBPLATE CETOP 3

OPIS TECHNICZNY / TECHNICAL DESCRIPTION

SCHEMAT HYDRAULICZNY / HYDRAULIC DIAGRAM

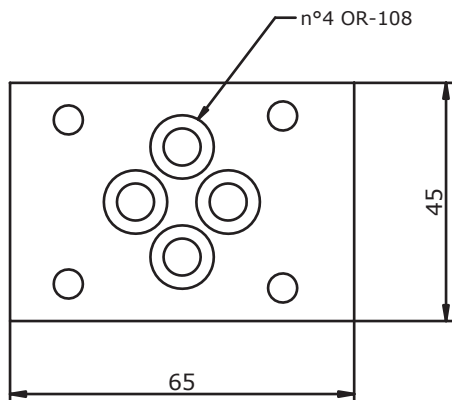
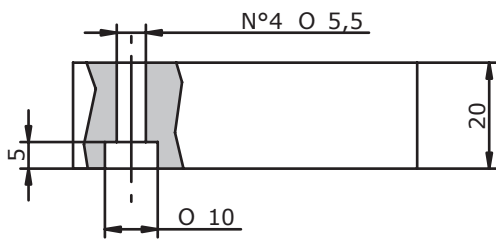
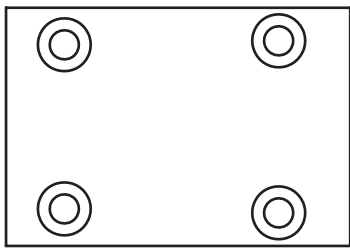
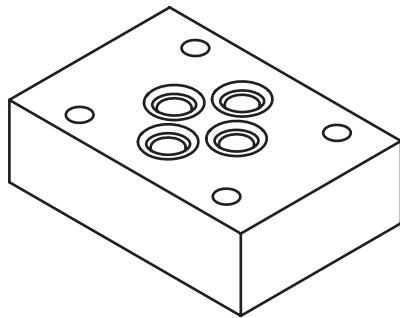

0

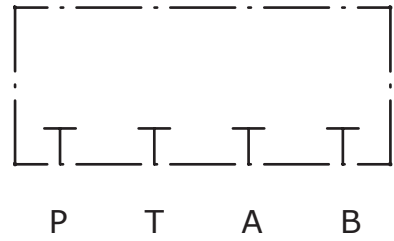

1

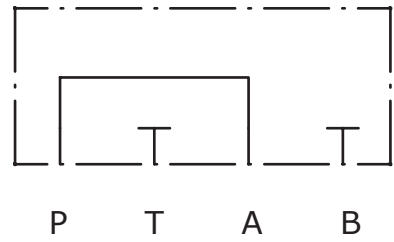

2

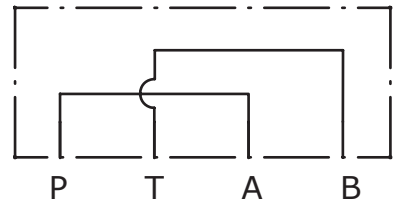

3

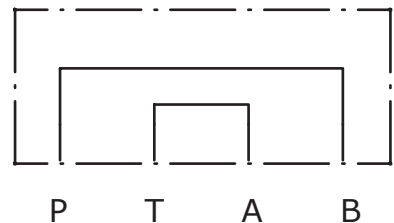

4



KOD ZAMÓWIENIA - ORDERING CODE

E_06 - 00 - 20 -

S = STAL / STEEL
A = ALUMINIUM / ALUMINUM

SCHEMAT / SEE DIAGRAMS

E_ 610 - 06 - _

Płyta przyłączeniowa NG6 (CETOP 3) do przekaźnika ciśnienia

PACKING PLATE CETOP 3 FOR PRESSURE SWITCH

OPIS TECHNICZNY / TECHNICAL DESCRIPTION

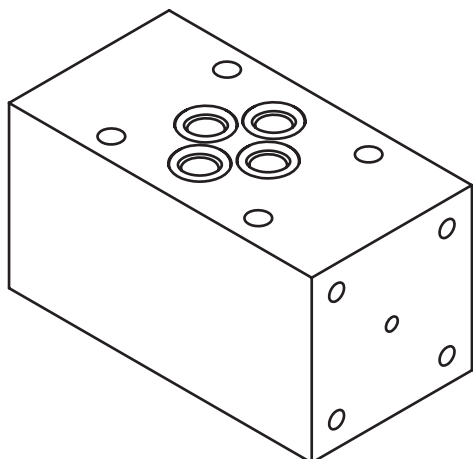

KOD		SCHEMAT / DIAGRAMS
1	A + B	STANDARDOWE / STANDARD
2	A	STANDARDOWE / STANDARD
3	B	STANDARDOWE / STANDARD
4	P + T	NA PROŚBĘ / ON REQUEST
5	P	STANDARDOWE / STANDARD
6	T	NA PROŚBĘ / ON REQUEST
7	P + P	NA PROŚBĘ / ON REQUEST

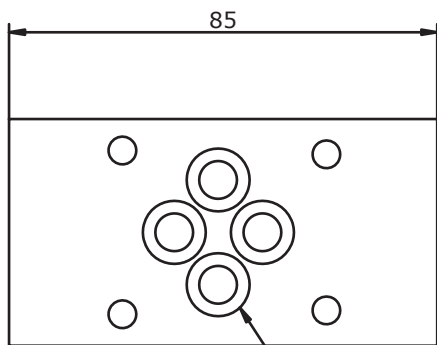
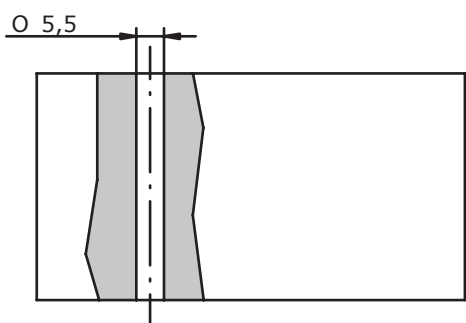

n°4 OR-108

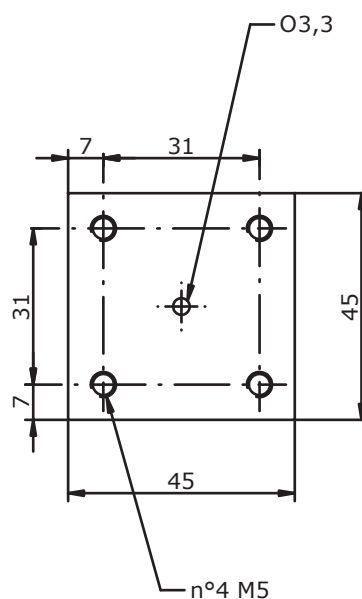

KOD ZAMÓWIENIA - ORDERING CODE

E_ 610 - 06 - _

S = STAL / STEEL
A = ALUMINIUM / ALUMINUM

SCHEMAT / SEE DIAGRAMS

E_06 - 07 -

Płyta przyłączeniowa NG6 (CETOP 3) porty A-B-P-T z dołu

SUBPLATE CETOP 3 WITH PORTS A-B-P-T BACK

OPIS TECHNICZNY / TECHNICAL DESCRIPTION

SCHEMAT HYDRAULICZNY / HYDRAULIC DIAGRAM

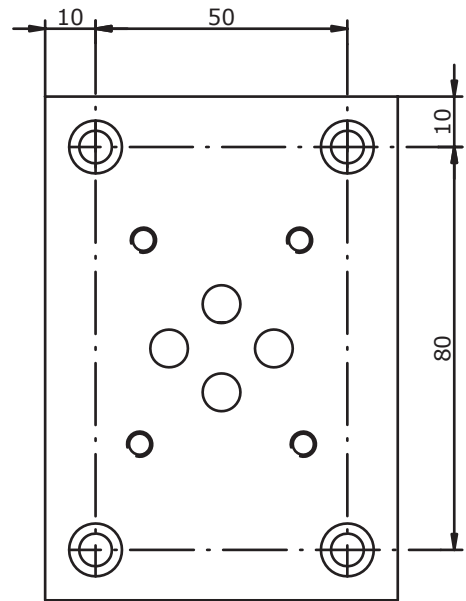
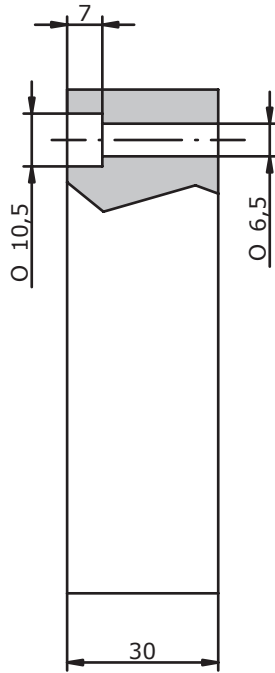
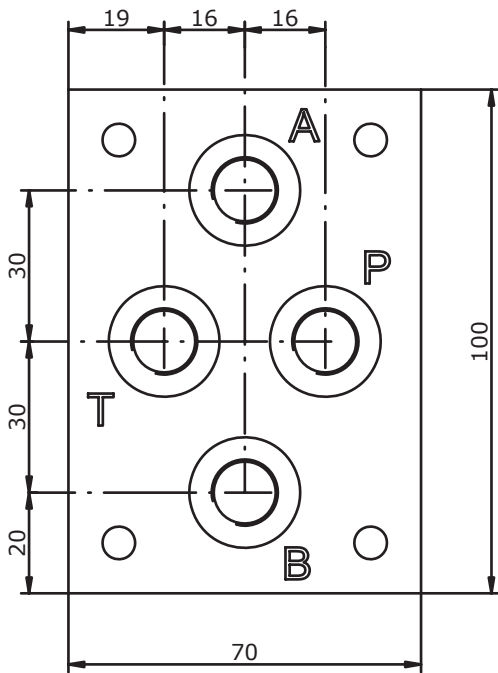
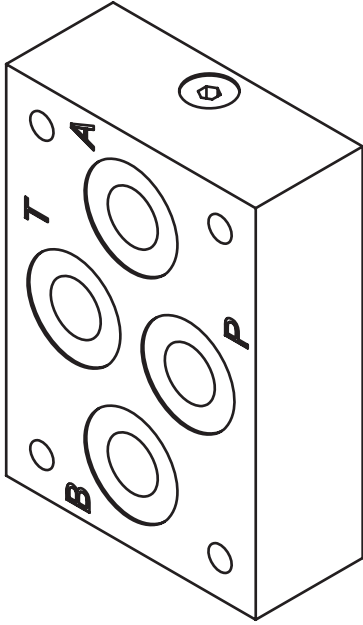

KOD ZAMÓWIENIA - ORDERING CODE

E_06 - 07 -

S = STAL / STEEL
A = ALUMINIUM / ALUMINIUM

14 = BSP 1/4G
38 = BSP 3/8G
12 = BSP 1/2G

E_06 - 08 -

Płyta przyłączeniowa NG6 (CETOP 3) porty A-B-P-T z boku

SUBPLATE CETOP 3 WITH PORTS A-B-P-T ON SIDE

OPIS TECHNICZNY / TECHNICAL DESCRIPTION

SCHEMAT HYDRAULICZNY / HYDRAULIC DIAGRAM

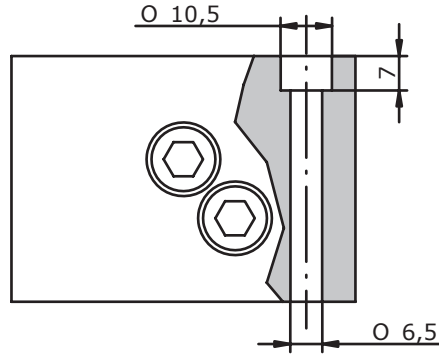
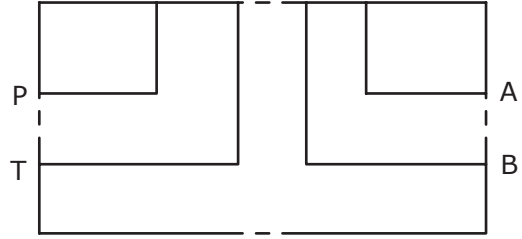
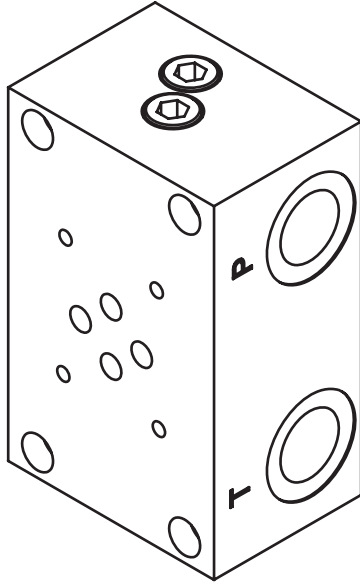

WERSJA / VERSION	R	L	M
E_06 - 08 - 14	45	15	27
E_06 - 08 - 38	45	15	27
E_06 - 08 - 12	50	17	29

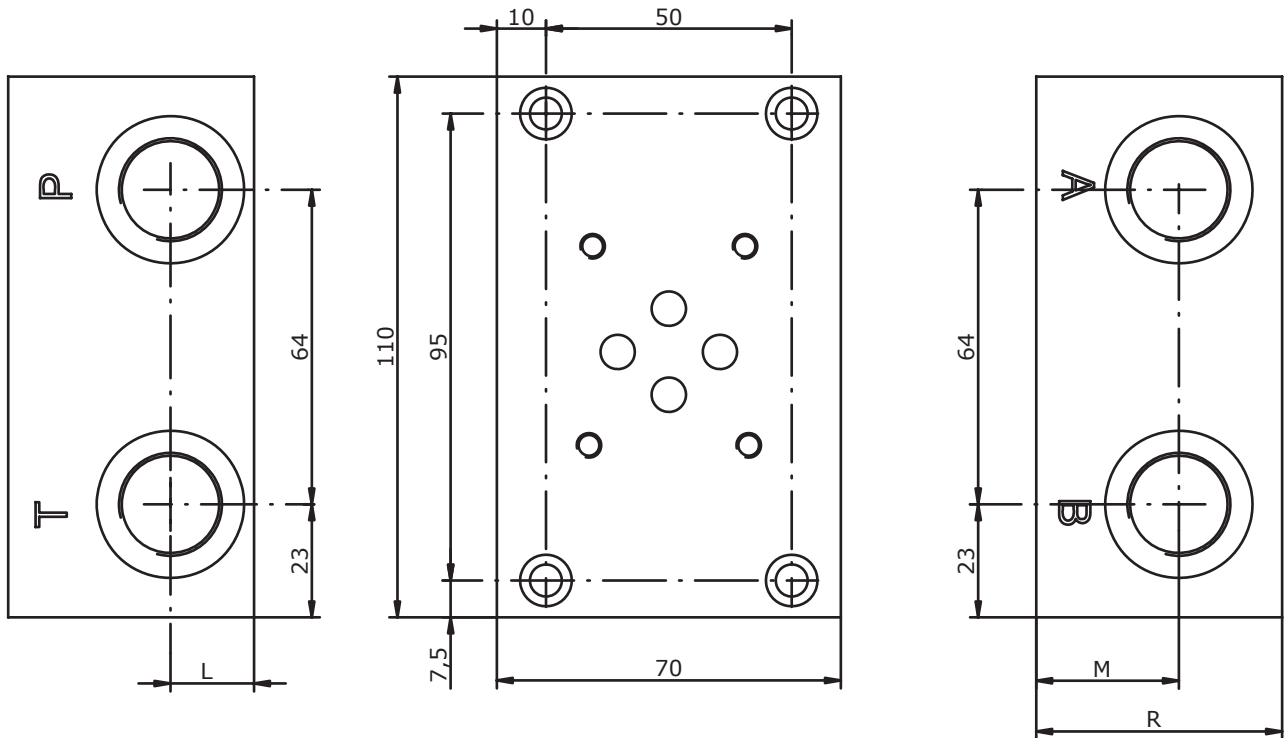

KOD ZAMÓWIENIA - ORDERING CODE

E_06 - 08 -

S = STAL / STEEL
A = ALUMINIUM / ALUMINUM

14 = BSP 1/4G
38 = BSP 3/8G
12 = BSP 1/2G

E_06 - 09 -

Płyta przyłączeniowa NG6 (CETOP 3) porty A-B-P-T z boku

SUBPLATE CETOP 3 WITH PORTS A-B-P-T ON SIDE

OPIS TECHNICZNY / TECHNICAL DESCRIPTION

SCHEMAT HYDRAULICZNY / HYDRAULIC DIAGRAM

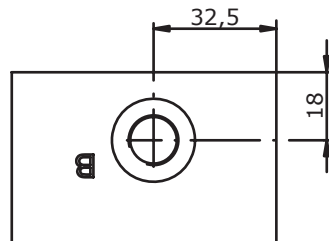
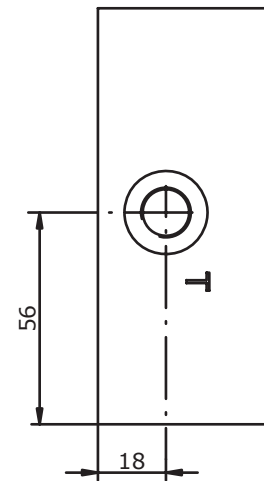
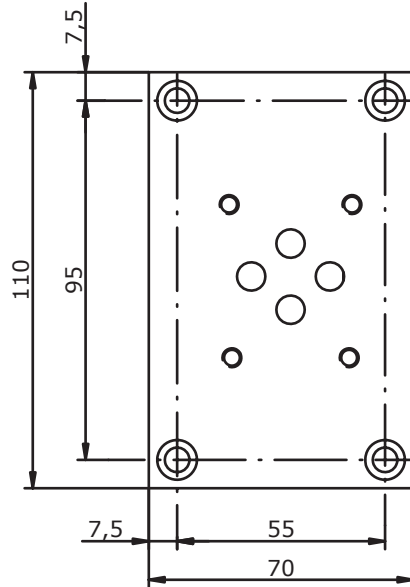
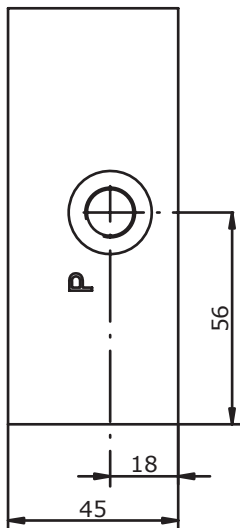
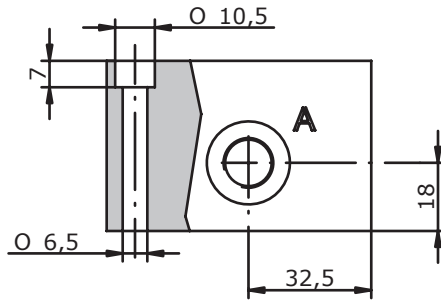
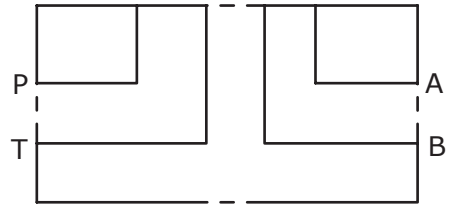
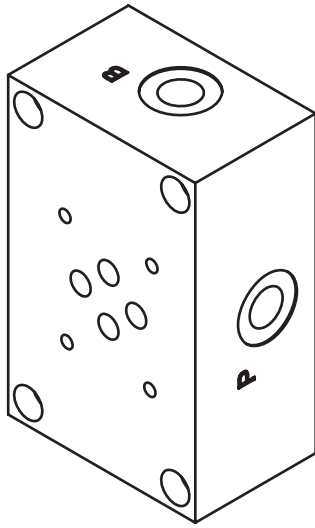

KOD ZAMÓWIENIA - ORDERING CODE

E_06 - 09 -

S = STAL / STEEL
A = ALUMINIUM / ALUMINUM

14 = BSP 1/4G
38 = BSP 3/8G
12 = BSP 1/2G

E_06 - 10 - 38

Płyta przyłączeniowa NG6 (CETOP 3) porty A-B-P-T z boku P-T z dołu

SUBPLATE CETOP 3 WITH PORTS A-B-P-T ON SIDE P-T BACK 3/8" BSP

OPIS TECHNICZNY / TECHNICAL DESCRIPTION

SCHEMAT HYDRAULICZNY / HYDRAULIC DIAGRAM

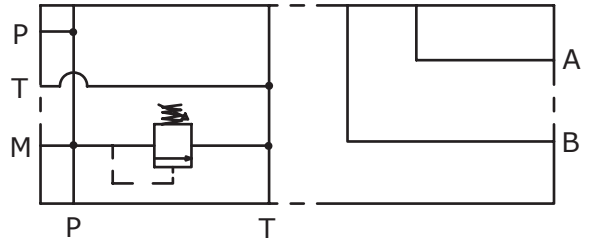

TYPY REGULACJI / REGULATION TYPE

	H	ŚRUBA REGULACYJNA SZEŚCIOKĄTNA / HEXAGONAL HEAD SCREW
	K	REGULACJA POKRĘTŁA / KNOB
	C	KAPTUREK / COVER CAP
	I	BRAK REGULACJI / NON ADJUSTABLE

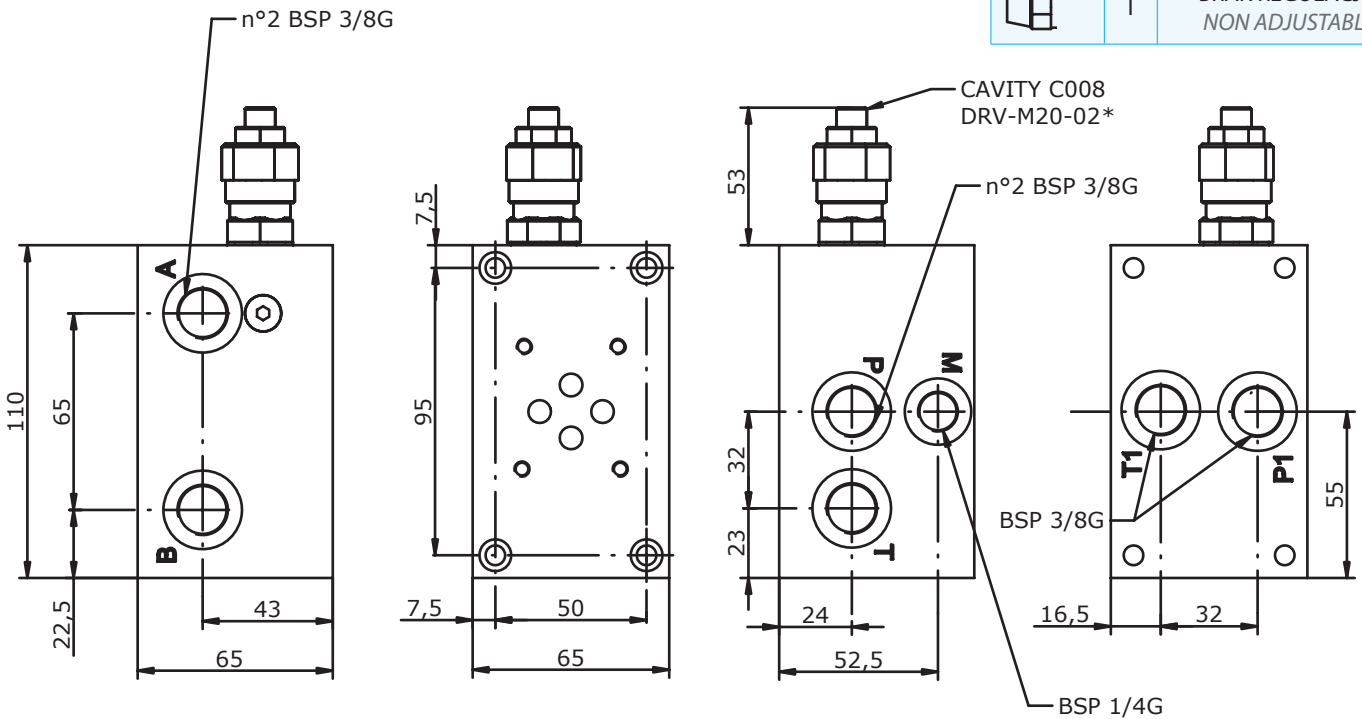
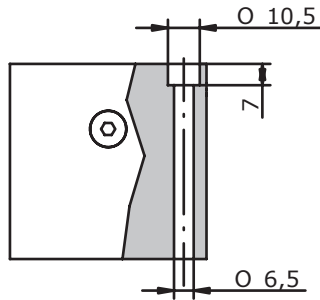
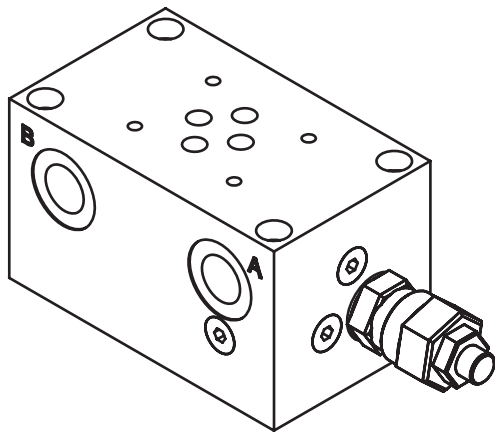

KOD ZAMÓWIENIA - ORDERING CODE

E_06 - 10 - 38 - - -

S = STAL / STEEL
A = ALUMINIUM / ALUMINUM

0 = BEZ ZAWORU PRZELEWOWEGO / WITHOUT RELIEF VALVE
1 = Z ZAWOREM PRZELEWOWYM / WITH RELIEF VALVE
2 = Z GNIAZDEM DO ZAWORU PRZELEWOWEGO / RELIEF VALVE READY

0 = BEZ ZAWORU PRZELEWOWEGO / WITHOUT RELIEF VALVE
H = ŚRUBA REGULACYJNA SZEŚCIOKĄTNA / HEXAGONAL HEAD SCREW
K = REGULACJA POKRĘTŁA / KNOB
C = KAPTUREK / COVER CAP
I = BRAK REGULACJI / NOT ADJUSTABLE

0 = BEZ ZAWORU PRZELEWOWEGO / WITHOUT R.V.
1 = 5 - 50 BAR
2 = 20 - 110 BAR
3 = 50 - 220 BAR
4 = 100 - 350 BAR
5 = 100 - 420 BAR

E_06 - 10 - 12

Płyta przyłączeniowa NG6 (CETOP 3) porty A-B z boku P-T z dołu

SUBPLATE CETOP 3 WITH PORTS A-B ON SIDE P-T BACK 1/2" BSP

OPIS TECHNICZNY / TECHNICAL DESCRIPTION

SCHEMAT HYDRAULICZNY / HYDRAULIC DIAGRAM

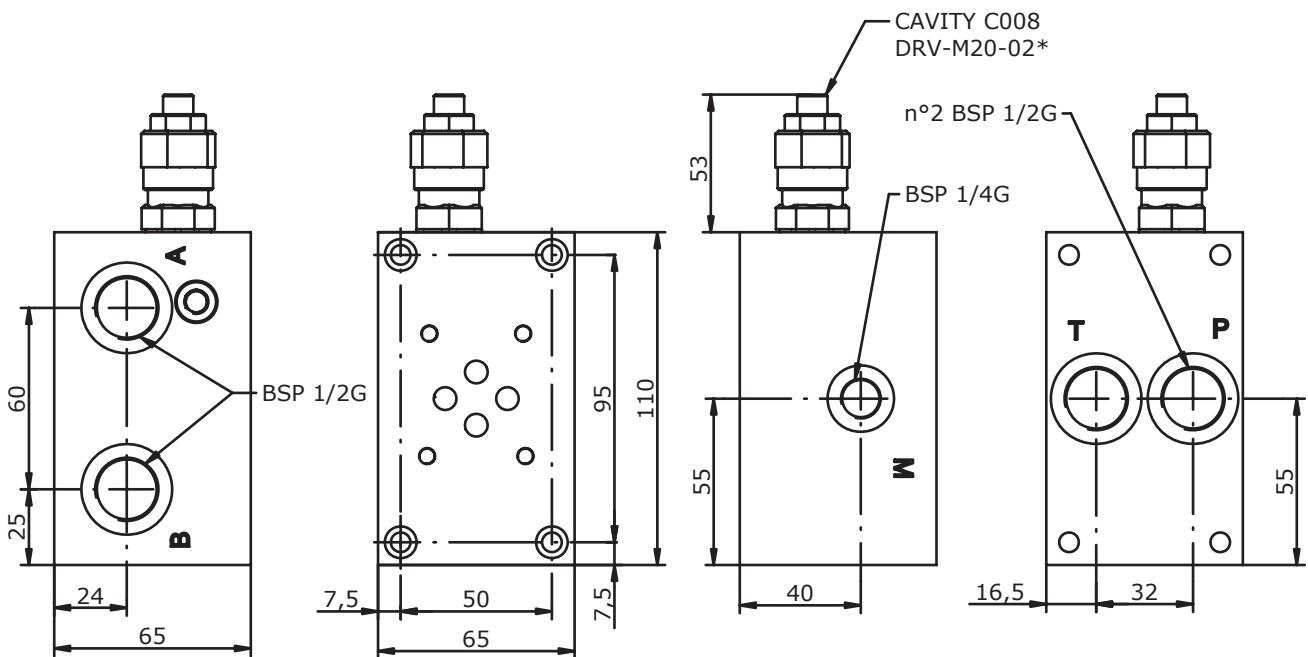
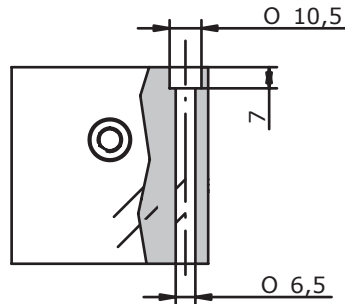
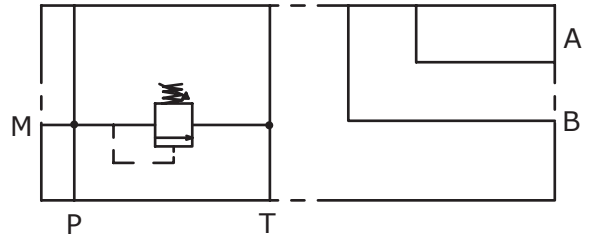
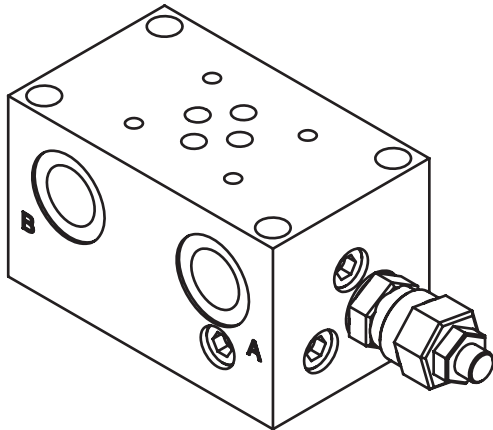

KOD ZAMÓWIENIA - ORDERING CODE

E_06 - 10 - 12 - - -

S = STAL / STEEL
A = ALUMINIUM / ALUMINUM

0 = BEZ ZAWORU PRZELEWOWEGO / WITHOUT RELIEF VALVE
1 = Z ZAWOREM PRZELEWOWYM / WITH RELIEF VALVE
2 = Z GNIAZDEM DO ZAWORU PRZELEWOWEGO / RELIEF VALVE READY

0 = BEZ ZAWORU PRZELEWOWEGO / WITHOUT RELIEF VALVE
H = ŚRUBA REGULACYJNA SZEŚCIOKĄTNA / HEXAGONAL HEAD SCREW
K = REGULACJA POKRĘTŁA / KNOB
C = KAPTUREK / COVER CAP
I = BRAK REGULACJI / NOT ADJUSTABLE

0 = BEZ ZAWORU PRZELEWOWEGO / WITHOUT R.V.
1 = 5 - 50 BAR
2 = 20 - 110 BAR
3 = 50 - 220 BAR
4 = 100 - 350 BAR
5 = 100 - 420 BAR

E_06 - 16 -

Płyta przyłączeniowa NG6 (CETOP 3) porty A-B-P-T z boku P-T z dołu

SUBPLATE CETOP 3 WITH PORTS A-B-P-T ON SIDE P-T BACK

OPIS TECHNICZNY / TECHNICAL DESCRIPTION

SCHEMAT HYDRAULICZNY / HYDRAULIC DIAGRAM

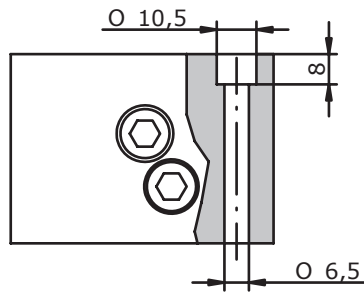
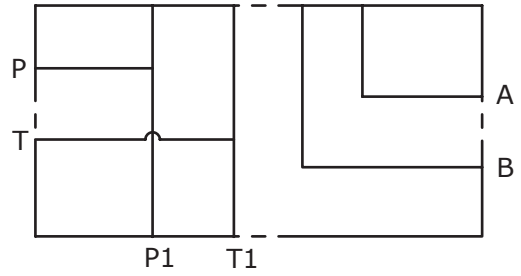
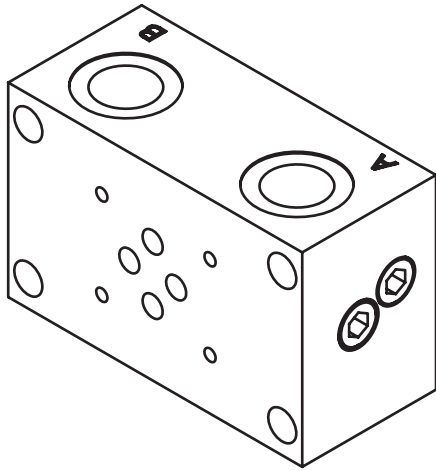

WERSJA / VERSION	R
E_06 - 16 - 14	45
E_06 - 16 - 38	45
E_06 - 16 - 12	50

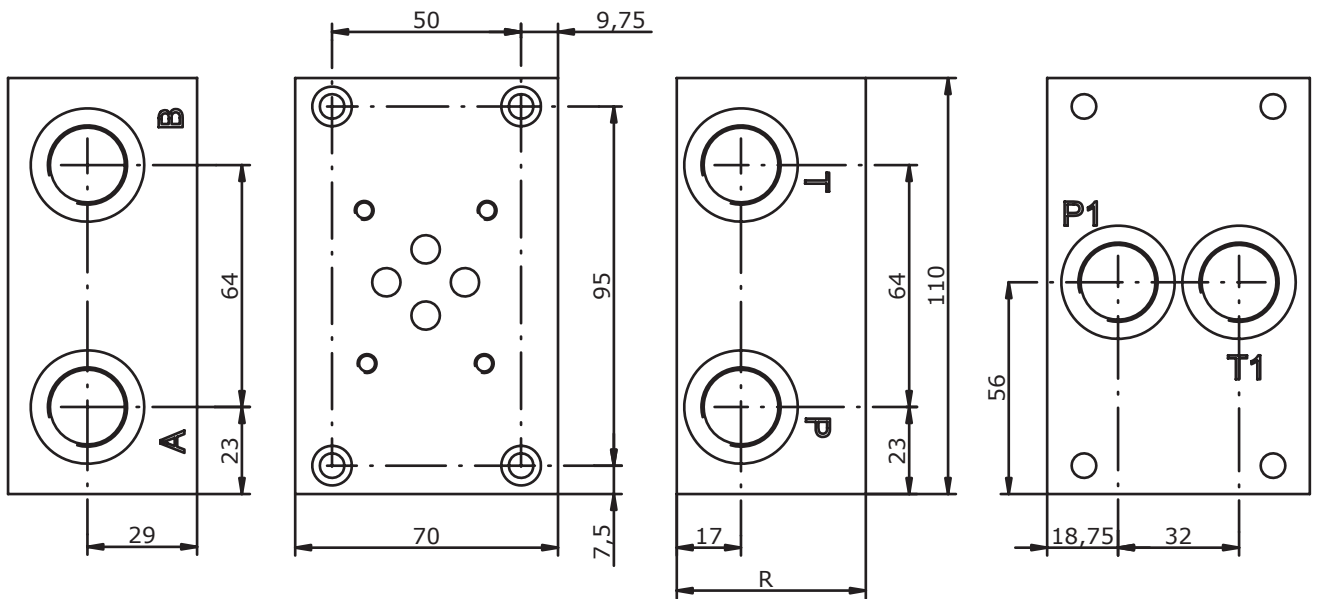

KOD ZAMÓWIENIA - ORDERING CODE

E_06 - 16 -

S = STAL / STEEL
A = ALUMINIUM / ALUMINUM

14 = BSP 1/4G
38 = BSP 3/8G
12 = BSP 1/2G

E_06 - 12 - 38

Płyta przyłączeniowa NG6 (CETOP 3) porty A-B z boku P-T z przodu

MONOBLOCK CETOP 3 WITH PORTS A-B ON SIDE 3/8" P-T CROSSING 1/2" BSP

OPIS TECHNICZNY / TECHNICAL DESCRIPTION

SCHEMAT HYDRAULICZNY / HYDRAULIC DIAGRAM

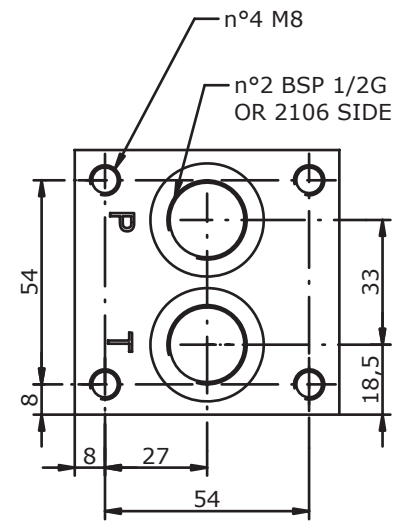
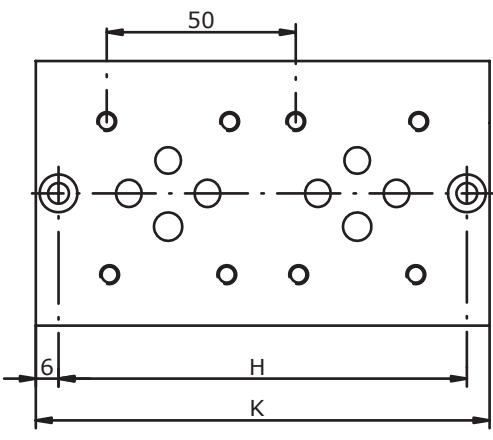
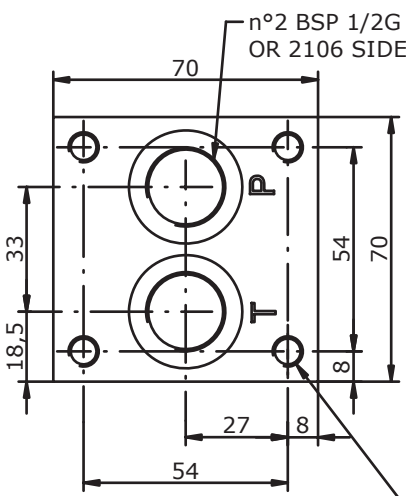
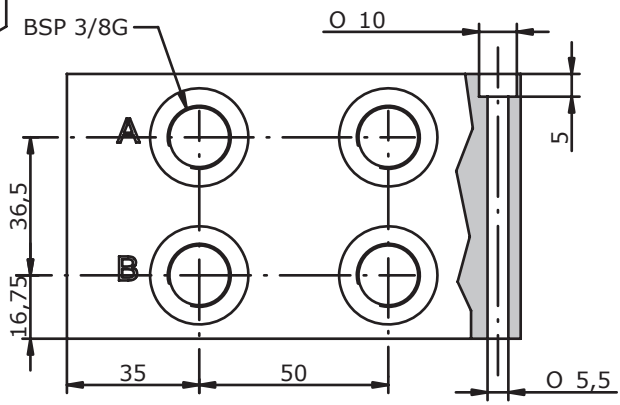
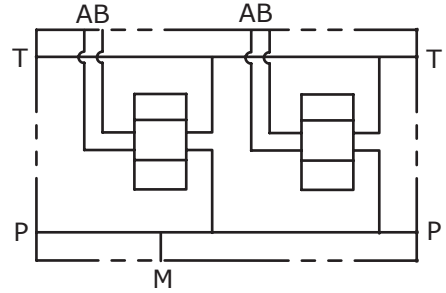
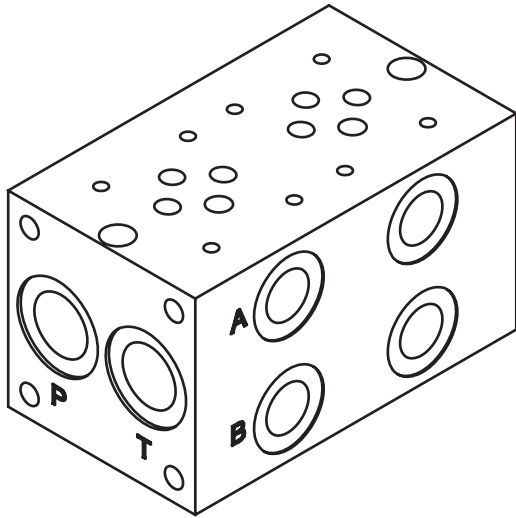

POS.	01	02	03	04	05	06	07	08	09	10
H	58	108	158	208	258	308	358	408	458	508
K	70	120	170	220	270	320	370	420	470	520

KOD ZAMÓWIENIA - ORDERING CODE

E_06 - 12 - 38 -

S = STAL / STEEL
A = ALUMINIUM / ALUMINUM

IŁOŚĆ SEKCJI / MOUNTING POSITIONS = 1 ÷ 10

E_06 - 14 - 38

Płyta przyłączeniowa NG6 (CETOP 3) porty A-B z boku P-T z przodu opcjonalnie z zaworem odciążającym

MONOBLOCK CETOP 3 WITH PORTS A-B ON SIDE 3/8" P-T CROSSING 1/2" BSP WITH OPTIONAL VENTING VALVE

OPIS TECHNICZNY / TECHNICAL DESCRIPTION

SCHEMAT HYDRAULICZNY / HYDRAULIC DIAGRAM

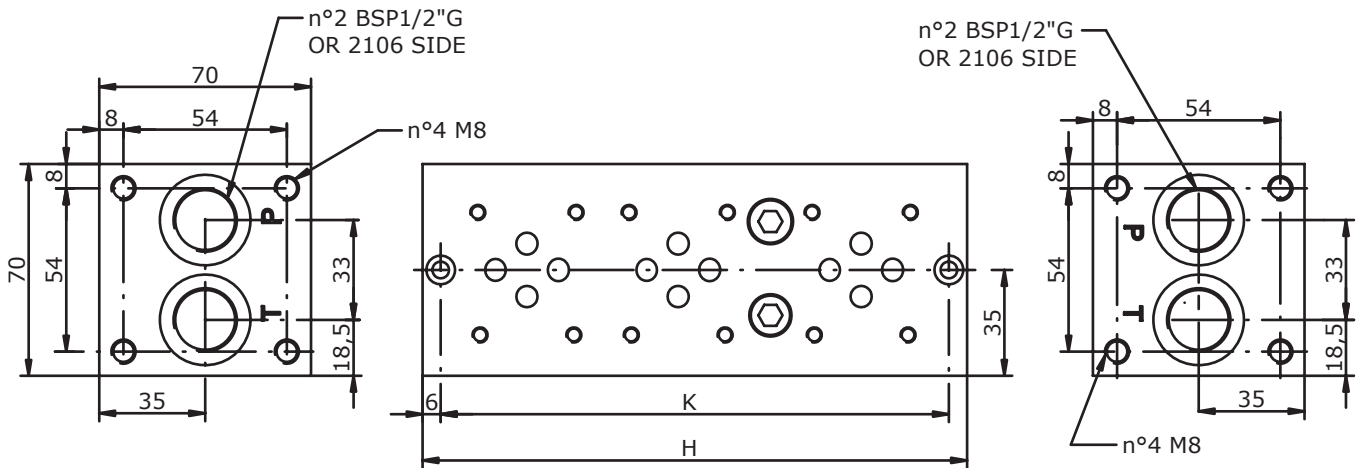
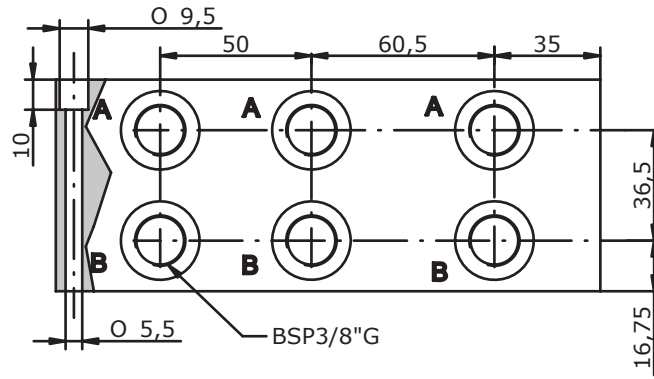
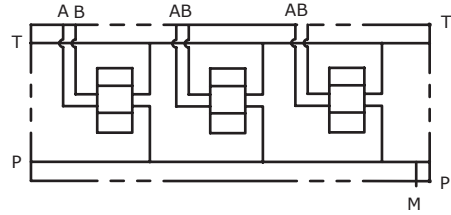
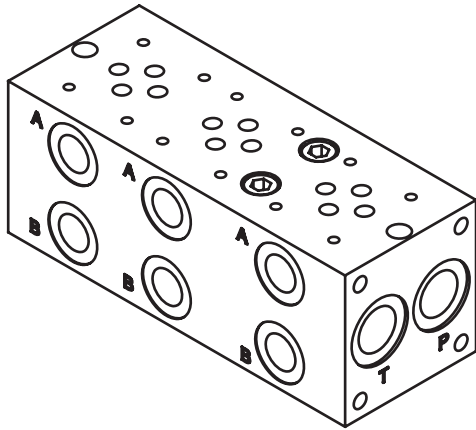

E_06 - 14 - 38 - _ - 0

POS.	01	02	03	04	05	06	07	08	09	10
H	90	130	180	230	280	330	380	430	480	530
K	78	118	168	218	268	318	368	418	468	518

E_06 - 14 - 38

Płyta przyłączeniowa NG6 (CETOP 3) porty A-B z boku P-T z przodu opcjonalnie z zaworem odciążającym

MONOBLOCK CETOP 3 WITH PORTS A-B ON SIDE 3/8" P-T CROSSING 1/2" BSP WITH OPTIONAL VENTING VALVE

OPIS TECHNICZNY / TECHNICAL DESCRIPTION

E_06 - 14 - 38 - ___ - 1

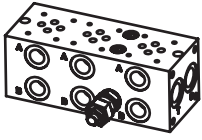

CAVITY C008
DRV-M20-02*

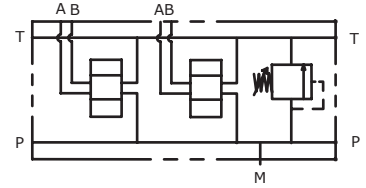
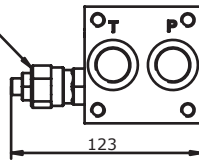

E_06 - 14 - 38 - ___ - 2

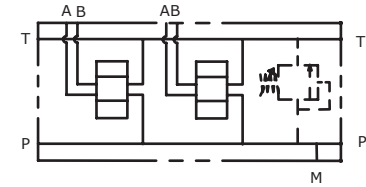
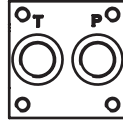
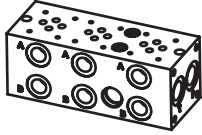

E_06 - 14 - 38 - ___ - 3

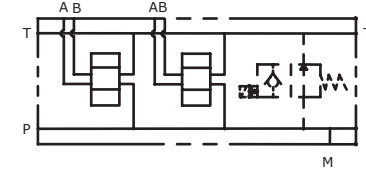
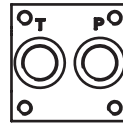
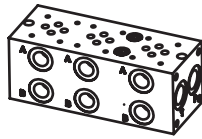

E_06 - 14 - 38 - ___ - 4

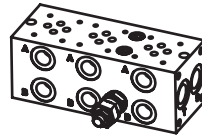

CAVITY C008
DRV-M20-02*

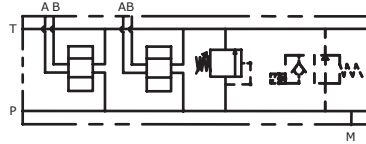
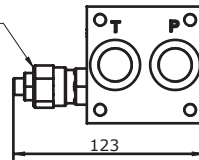

E_06 - 14 - 38 - ___ - 5

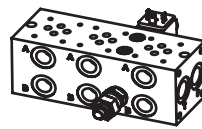

CAVITY C008
DRV-M20-02*

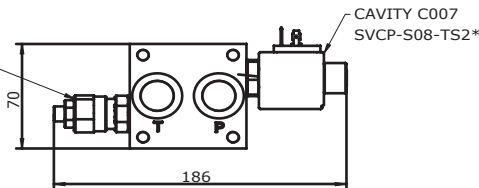

CAVITY C007
SVCPS08-TS2*

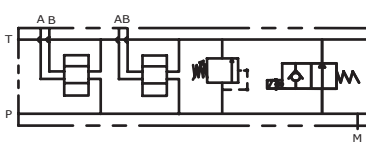

E_06 - 14 - 38 - ___ - 6

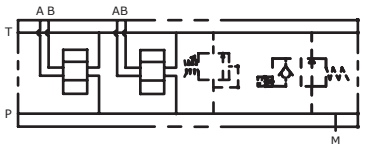
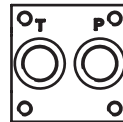
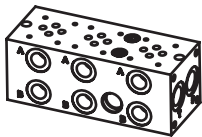

KOD ZAMÓWIENIA - ORDERING CODE

E_06 - 14 - 38 -

S = STAL / STEEL
A = ALUMINIUM / ALUMINIUM

ILOŚĆ SEKCJI / MOUNTING POSITIONS = 1 ± 10

0 = BEZ ZAWORU PRZELEWOWEGO / WITHOUT RELIEF VALVE
1 = Z ZAWOREM PRZELEWOWYM / WITH RELIEF VALVE
2 = Z GNIAZDEM DO ZAWORU PRZELEWOWEGO / RELIEF VALVE READY
3 = Z GNIAZDEM DO ZAWORU ODCIĄŻAJĄCEGO / VENTING VALVE READY
4 = Z ZAWOREM PRZELEWOWYM I GNIAZDEM DO ZAWORU ODCIĄŻAJĄCEGO / WITH RV AND VV READY
5 = Z ZAWOREM PRZELEWOWYM I ODCIĄŻAJĄCYM / WITH RV AND VV
6 = Z GNIAZDEM DO ZAWORU PRZELEWOWEGO I ODCIĄŻAJĄCEGO / VV READY AND RV READY

0 = BEZ ZAWORU PRZELEWOWEGO / WITHOUT RV
1 = 5 - 50 BAR
2 = 20 - 110 BAR
3 = 50 - 220 BAR
4 = 100 - 350 BAR
5 = 100 - 420 BAR

0 = BEZ ZAWORU PRZELEWOWEGO / WITHOUT RELIEF VALVE
H = ŚRUBA REGULACYJNA SZEŚCIOKĄTNA / HEX. HEAD SCREW
K = REGULACJA POKRĘTLEM / KNOB
C = KAPTUREK / COVER CAP
I = BRAK REGULACJI / NOT ADJUSTABLE

ZAWÓR ODCIĄŻAJĄCY / VENTING VALVE
000 = BEZ ZAWORU ODCIĄŻAJĄCEGO / WITHOUT VV
TS2 = NORMALNIE OTWARTY / NORMALLY OPEN

USZCZELNIENIE / SEALS
N = NBR
V = VITON

TYP WTYCZKI / CONNECTOR TYPE
0 = BEZ CEWKI / WITHOUT COIL
C = CAVI / LEADS
D = DIN 43650
G = DEUTSCH DT04-2P
A = AMP JUNIOR

NAPIĘCIE / TENSIONE / VOLTAGE
000 = BEZ CEWKI / WITHOUT COIL
D12 = 12 VDC
D24 = 24 VDC
220 = 220 RAC

ZAWÓR ODCIĄŻAJĄCY / VENTING VALVE
0 = BEZ RĘCZNEGO PRZESTEROWANIA / NO MANUAL OVERRIDE
3 = PRZESTEROWANIE SZPILKĄ / PUSH PIN
4 = PRZESTEROWANIE PRZYCISKIEM / PUSH BOTTOM
5 = PRZESTEROWANIE KLUCZEM IMBUSOWYM / HEX ALLEN

E_06 - 21 - 38

Płyta przyłączeniowa NG6 (CETOP 3) porty A-B z boku P-T z przodu opcjonalnie z zaworem odciążającym

MONOBLOCK CETOP 3 WITH PORTS A-B ON SIDE 3/8" BSP P-T CROSSING 1/2" BSP WITH OPTIONAL VENTING

OPIS TECHNICZNY / TECHNICAL DESCRIPTION

SCHEMAT HYDRAULICZNY / HYDRAULIC DIAGRAM

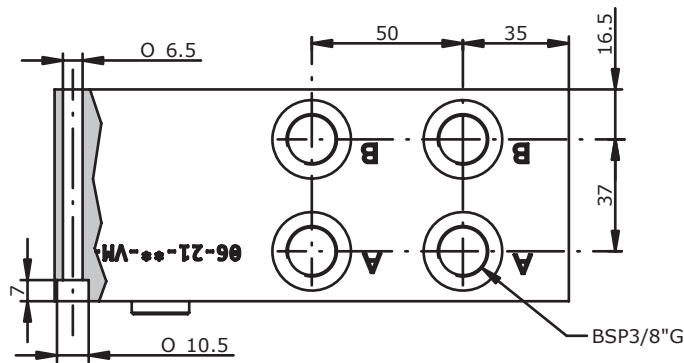
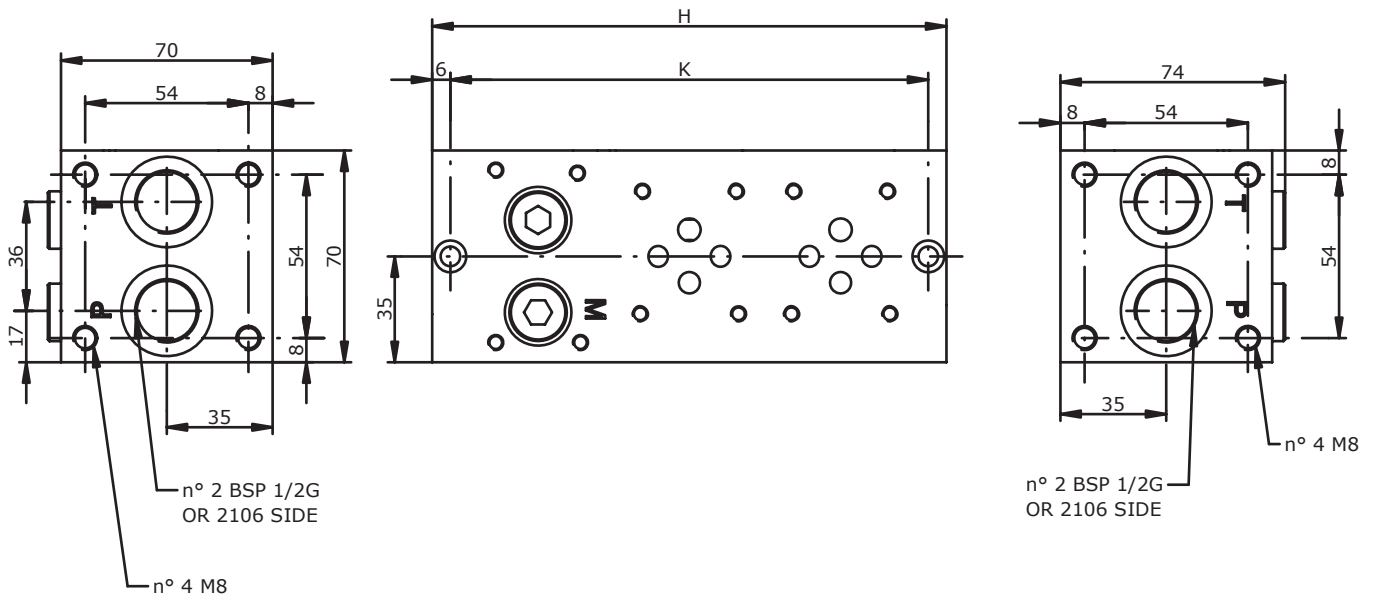
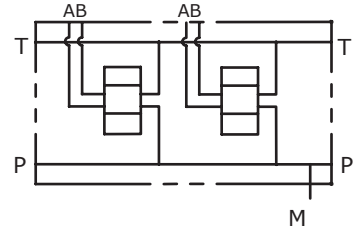
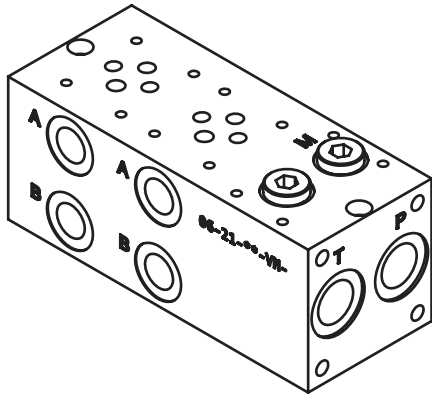

E_06 - 21 - 38 - _ - 0

POS.	01	02	03	04	05	06	07	08	09	10
H	120	170	220	270	320	370	420	470	520	570
K	108	158	208	258	308	358	408	458	508	558

E_06 - 21 - 38

Płyta przyłączeniowa NG6 (CETOP 3) porty A-B z boku P-T z przodu opcjonalnie z zaworem odciążającym

MONOBLOCK CETOP 3 WITH PORTS A-B ON SIDE 3/8" BSP P-T CROSSING 1/2" BSP WITH OPTIONAL VENTING VALVE

OPIS TECHNICZNY / TECHNICAL DESCRIPTION

E_06 - 21 - 38 - ___ - 1

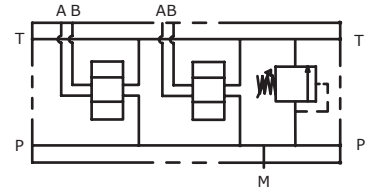
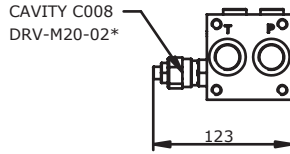
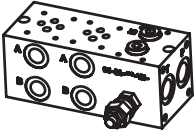

E_06 - 21 - 38 - ___ - 2

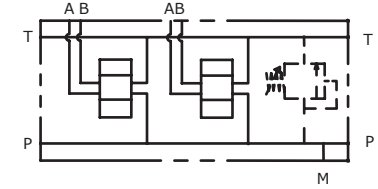
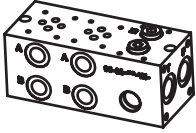

E_06 - 21 - 38 - ___ - 3

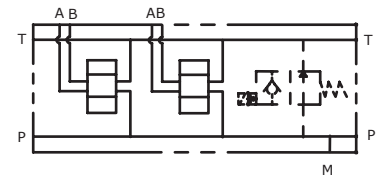

E_06 - 21 - 38 - ___ - 4

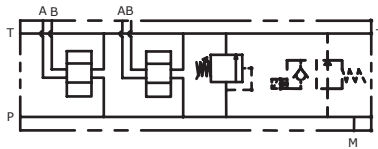
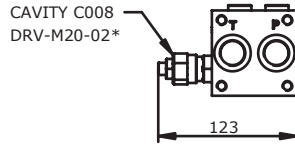
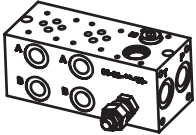

E_06 - 21 - 38 - ___ - 5

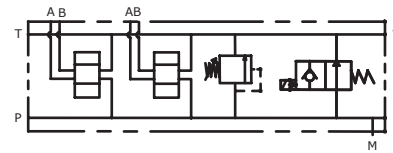
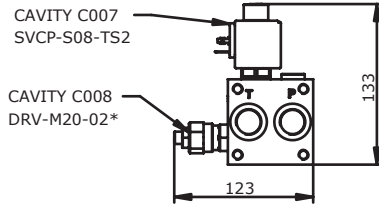
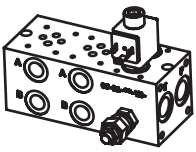

E_06 - 21 - 38 - ___ - 6

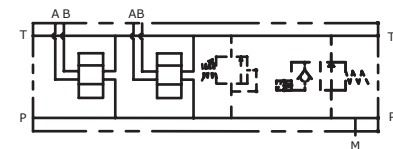
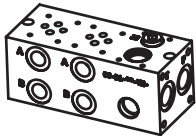

KOD ZAMÓWIENIA - ORDERING CODE

E_06 - 21 - 38 -

S = STAL / STEEL
A = ALUMINIUM / ALUMINIUM

ILOŚĆ SEKCJI / MOUNTING POSITIONS = 1 ÷ 10

0 = BEZ ZAWORU PRZELEWOWEGO / WITHOUT RELIEF VALVE
1 = Z ZAWOREM PRZELEWOWYM / WITH RELIEF VALVE
2 = Z GNIAZDEM DO ZAWORU PRZELEWOWEGO / RELIEF VALVE READY
3 = Z GNIAZDEM DO ZAWORU ODCIĄŻAJĄCEGO / VENTING VALVE READY
4 = Z ZAWOREM PRZELEWOWYM I GNIAZDEM DO ZAWORU ODCIĄŻAJĄCEGO / WITH R.V. AND V.V. READY
5 = Z ZAWOREM PRZELEWOWYM I ODCIĄŻAJĄCYM / WITH R.V. AND V.V. READY
6 = Z GNIAZDEM DO ZAWORU PRZELEWOWEGO I ODCIĄŻAJĄCEGO / V.V. READY AND R.V. READY

0 = BEZ ZAWORU PRZELEWOWEGO / WITHOUT R.V.
1 = 5 - 50 BAR
2 = 20 - 110 BAR
3 = 50 - 220 BAR
4 = 100 - 350 BAR
5 = 100 - 420 BAR

USZCZELNIENIE / SEALS
N = NBR
V = VITON

TYP WTYCZKI / CONNECTOR TYPE
0 = BEZ CEWKI / WITHOUT COIL
C = CAVI / LEADS
D = DIN 43650
G = DEUTSCH DT04 - 2P
A = AMP JUNIOR

NAPIĘCIE / TENSIONE / VOLTAGE
000 = BEZ CEWKI / WITHOUT COIL
D12 = 12 VDC
D24 = 24 VDC
220 = 220 RAC

0 = BEZ ZAWORU PRZELEWOWEGO / WITHOUT RELIEF VALVE
H = ŚRUBA REGULACYJNA SZEŚCIKĄTNA / HEX. HEAD SCREW
K = REGULACJA POKRĘTLEM / KNOB
C = KAPTUREK / COVER CAP
I = BRAK REGULACJI / NOT ADJUSTABLE

ZAWÓR ODCIĄŻAJĄCY / VENTING VALVE
000 = BEZ ZAWORU ODCIĄŻAJĄCEGO / WITHOUT V.V.
TS2 = NORMALNIE OTWARTY / NORMALLY OPEN

ZAWÓR ODCIĄŻAJĄCY / VENTING VALVE
0 = BEZ RĘCZNEGO PRZESTEROWANIA / NO MANUAL OVERRIDE
3 = PRZESTEROWANIE SZPILKĄ / PUSH PIN
4 = PRZESTEROWANIE PRZYCSKIEM / PUSH BOTTOM
5 = PRZESTEROWANIE KLUCZEM IMBUSOWYM / HEX. ALLEN

E_06 - 13 - 38

Płyta przyłączeniowa NG6 (CETOP 3) porty A-B z dołu P-T z przodu opcjonalnie z zaworem odciążającym

MONOBLOCK CETOP 3 WITH PORTS A-B BACK 3/8" P-T CROSSING 1/2" WITH OPTIONAL VENTING VALVE

OPIS TECHNICZNY / TECHNICAL DESCRIPTION

SCHEMAT HYDRAULICZNY / HYDRAULIC DIAGRAM

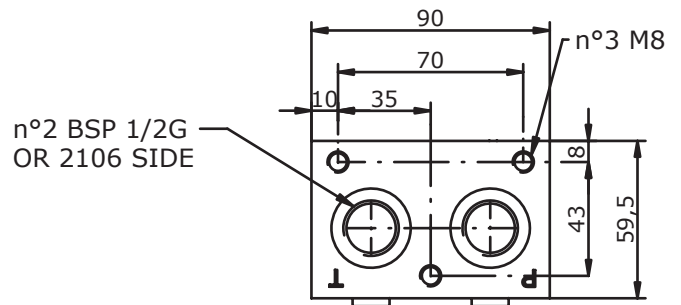
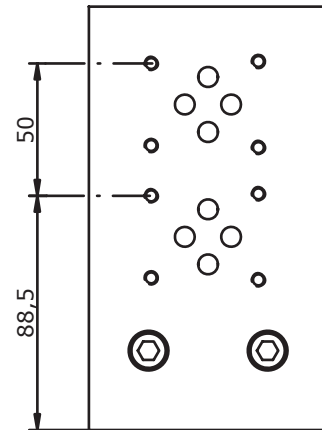
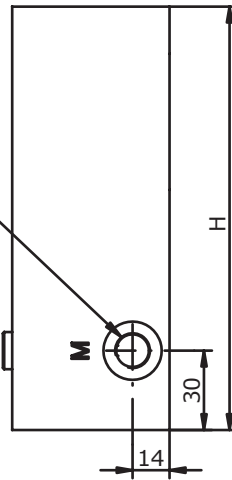
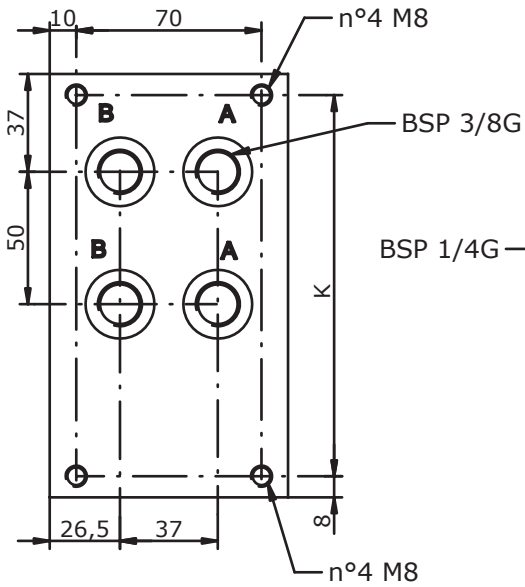
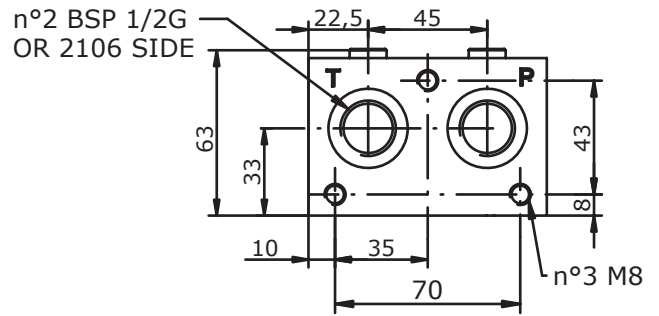
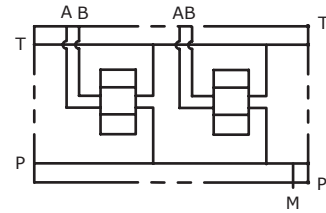
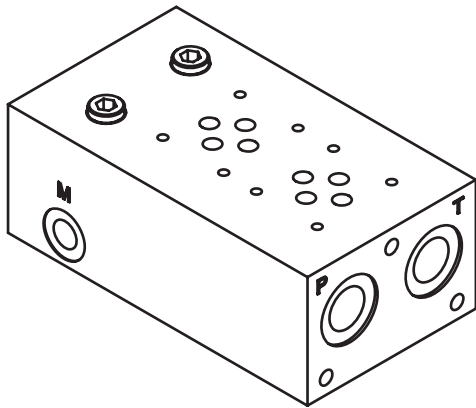

E_06 - 13 - 38 - _ - 0

POS.	01	02	03	04	05	06	07	08	09	10
H	110	160	210	260	310	360	410	460	510	560
K	94	144	194	244	294	344	394	444	494	544

E_06 - 13 - 38

Płyta przyłączeniowa NG6 (CETOP 3) porty A-B z dołu P-T z przodu opcjonalnie z zaworem odciążającym

MONOBLOCK CETOP 3 WITH PORTS A-B BACK 1/2" P-T CROSSING 1/2" WITH OPTIONAL VENTING VALVE

OPIS TECHNICZNY / TECHNICAL DESCRIPTION

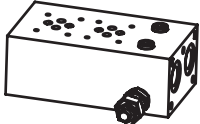
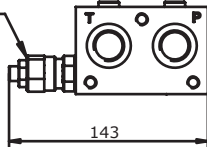
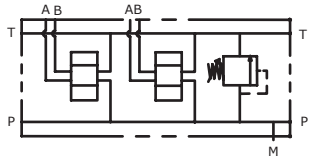
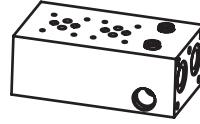
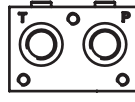
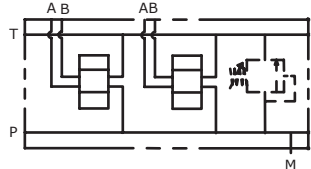
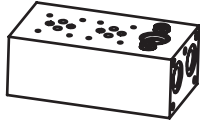
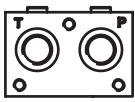
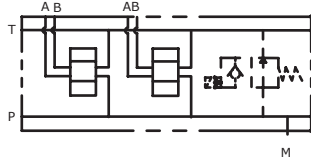
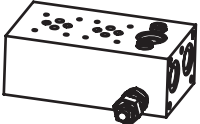
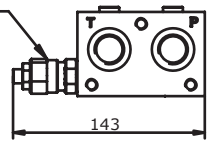
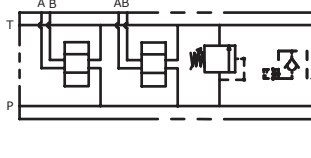
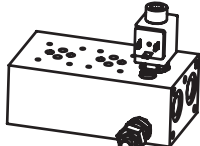
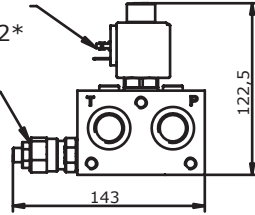
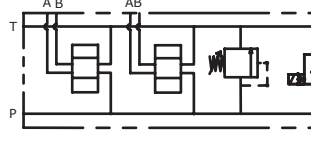
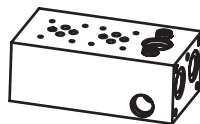
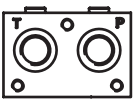
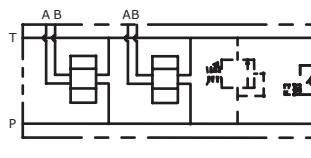
<p>E_06 - 13 - 38 - __ - 1</p> 	<p>CAVITY C008 DRV-M20-02*</p> 	
<p>E_06 - 13 - 38 - __ - 2</p> 		
<p>E_06 - 13 - 38 - __ - 3</p> 		
<p>E_06 - 13 - 38 - __ - 4</p> 	<p>CAVITY C008 DRV-M20-02*</p> 	
<p>E_06 - 13 - 38 - __ - 5</p> 	<p>CAVITY C007 SVCP-S08-TS2*</p> <p>CAVITY C008 DRV-M20-02*</p> 	
<p>E_06 - 13 - 38 - __ - 6</p> 		

KOD ZAMÓWIENIA - ORDERING CODE

E_06 - 13 - 38 -

S = STAL / STEEL
A = ALUMINIUM / ALUMINIUM

ILOŚĆ SEKCJI / MOUNTING POSITIONS = 1 ÷ 10

0 = BEZ ZAWORU PRZELEWOWEGO / WITHOUT RELIEF VALVE
1 = Z ZAWOREM PRZELEWOWYM / WITH RELIEF VALVE
2 = Z GNIAZDEM DO ZAWORU PRZELEWOWEGO / RELIEF VALVE READY
3 = Z GNIAZDEM DO ZAWORU ODCIĄŻAJĄCEGO / VENTING VALVE READY
4 = Z ZAWOREM PRZELEWOWYM I GNIAZDEM DO ZAWORU ODCIĄŻAJĄCEGO / WITH R.V. AND V.V. READY
5 = Z ZAWOREM PRZELEWOWYM I ODCIĄŻAJĄCYM / WITH R.V. AND V.V.
6 = Z GNIAZDEM DO ZAWORU PRZELEWOWEGO I ODCIĄŻAJĄCEGO / V.V. READY AND R.V. READY

0 = BEZ ZAWORU PRZELEWOWEGO / WITHOUT R.V.
1 = 5 - 50 BAR
2 = 20 - 110 BAR
3 = 50 - 220 BAR
4 = 100 - 350 BAR
5 = 100 - 420 BAR

0 = BEZ ZAWORU PRZELEWOWEGO / WITHOUT RELIEF VALVE
H = ŚRUBA REGULACYJNA SZEŚCIOKĄTNA / HEX. HEAD SCREW
K = REGULACJA POKRĘTŁEM / KNOB
C = KAPTUREK / COVER CAP
I = BRAK REGULACJI / NOT ADJUSTABLE

ZAWÓR ODCIĄŻAJĄCY / VENTING VALVE
000 = BEZ ZAWORU ODCIĄŻAJĄCEGO / WITHOUT V.V.
TS2 = NORMALNIE OTWARTY / NORMALLY OPEN

USZCZELNIENIE / SEALS
N = NBR
V = VITON

ZAWÓR ODCIĄŻAJĄCY / VENTING VALVE
0 = BEZ RĘCZNEGO PRZESTEROWANIA / NO MANUAL OVERRIDE
3 = PRZESTEROWANIE SZPILKĄ / PUSH PIN
4 = PRZESTEROWANIE PRZYCISKIEM / PUSH BOTTOM
5 = PRZESTEROWANIE KLUCZEM IMBUSOWYM / HEX. ALLEN

TYP WTYCZKI / CONNECTOR TYPE
0 = BEZ CEWKI / WITHOUT COIL
C = CAVI / LEADS
D = DIN 43650
G = DEUTSCH DT04 - 2P
A = AMP JUNIOR

NAPIĘCIE / TENSIONE / VOLTAGE
000 = BEZ CEWKI / WITHOUT COIL
D12 = 12 VDC
D24 = 24 VDC
220 = 220 RAC

E_06 - 13 - 12

Płyta przyłączeniowa NG6 (CETOP 3) porty A-B z dołu P-T z przodu opcjonalnie z zaworem odciążającym

MONOBLOCK CETOP 3 WITH PORTS A-B BACK 1/2" P-T CROSSING 1/2" WITH OPTIONAL VENTING VALVE

OPIS TECHNICZNY / TECHNICAL DESCRIPTION

SCHEMAT HYDRAULICZNY / HYDRAULIC DIAGRAM

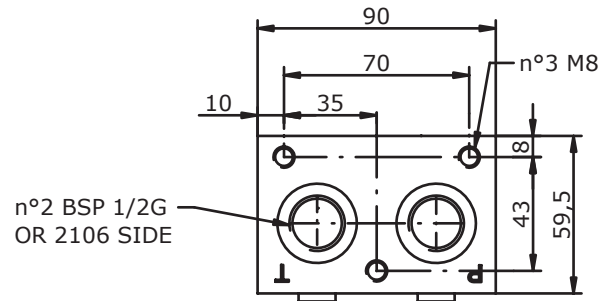
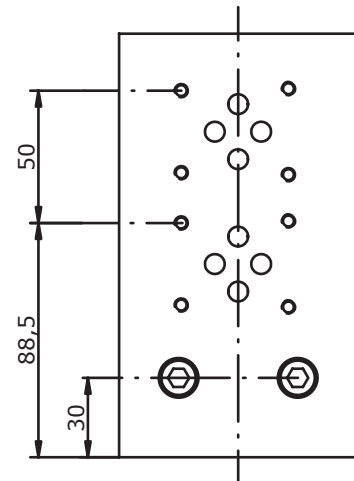
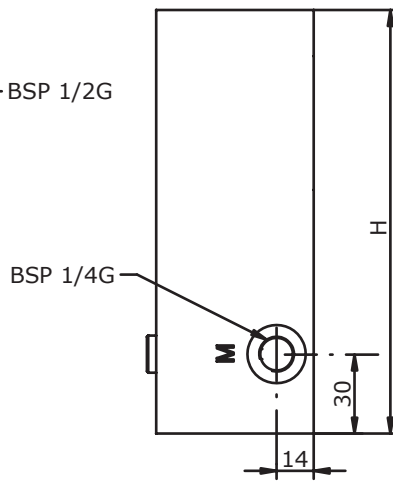
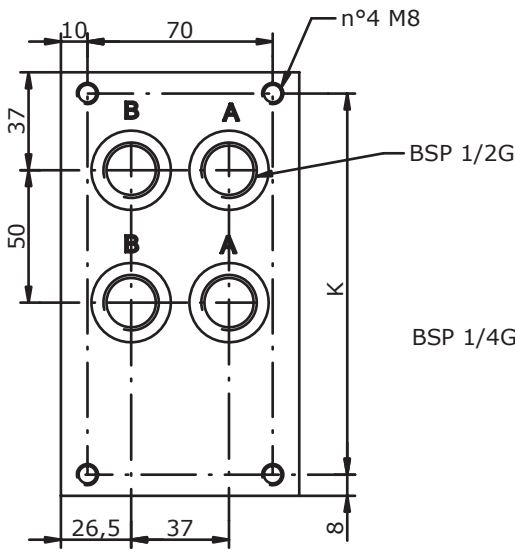
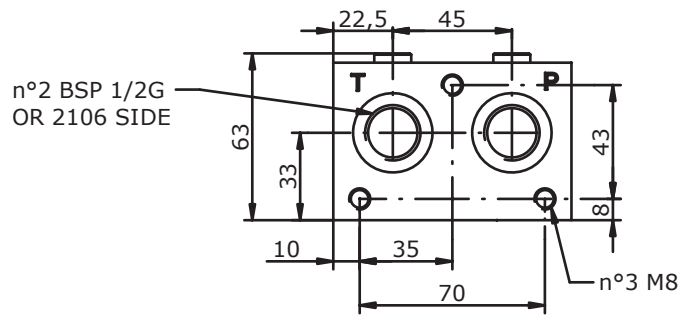
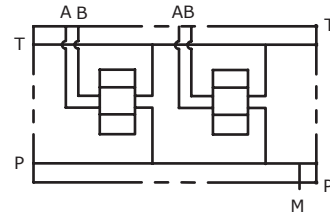
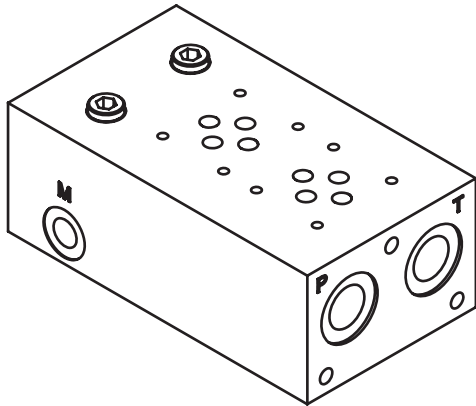



E_06 - 13 - 12 - _ - 0

POS.	01	02	03	04	05	06	07	08	09	10
H	110	160	210	260	310	360	410	460	510	560
K	94	144	194	244	294	344	394	444	494	544

E_06 - 13 - 12

Płyta przyłączeniowa NG6 (CETOP3) porty A-B z dołu P-T z przodu opcjonalnie z zaworem odciążającym
 MONOBLOCK CETOP 3 WITH PORTS A-B BACK 1/2" P-T CROSSING 1/2" WITH OPTIONAL VENTING VALVE

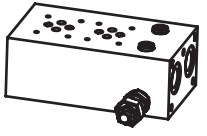
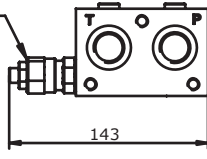
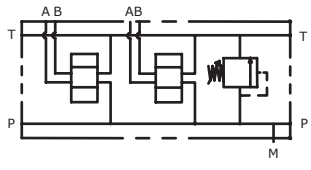
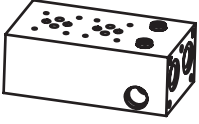
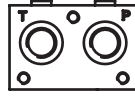
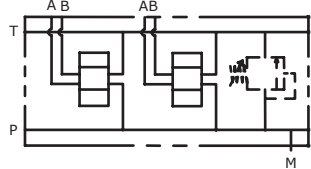
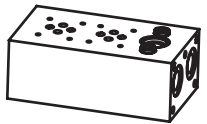
OPIS TECHNICZNY / TECHNICAL DESCRIPTION

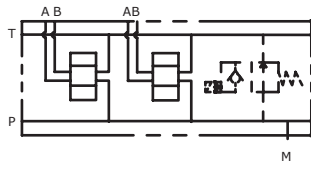
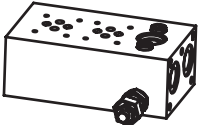
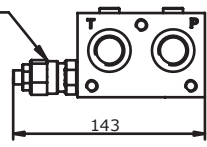
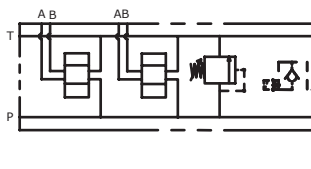
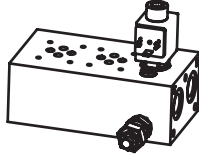
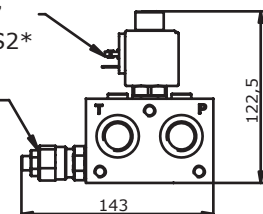
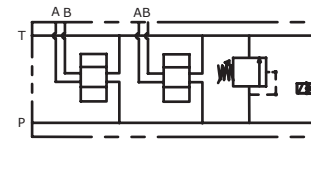
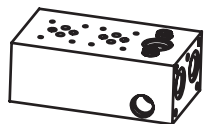
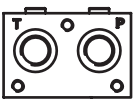
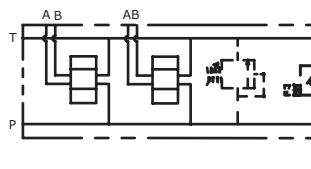
<p>E_06 - 13 - 12 - __ - 1</p> 	<p>CAVITY C008 DRV-M20-02*</p> 	
<p>E_06 - 13 - 12 - __ - 2</p> 		
<p>E_06 - 13 - 12 - __ - 3</p> 		
<p>E_06 - 13 - 12 - __ - 4</p> 	<p>CAVITY C008 DRV-M20-02*</p> 	
<p>E_06 - 13 - 12 - __ - 5</p> 	<p>CAVITY C007 SVCP-S08-TS2*</p> <p>CAVITY C008 DRV-M20-02*</p> 	
<p>E_06 - 13 - 12 - __ - 6</p> 		

KOD ZAMÓWIENIA - ORDERING CODE

E_06 - 13 - 12 -

S = STAL / STEEL
A = ALUMINIUM / ALUMINIUM

ILOŚĆ SEKCJI / MOUNTING POSITIONS = 1 ± 10

0 = BEZ ZAWORU PRZELEWOWEGO / WITHOUT RELIEF VALVE
1 = Z ZAWOREM PRZELEWOWYM / WITH RELIEF VALVE
2 = Z GNIAZDEM DO ZAWORU PRZELEWOWEGO / RELIEF VALVE READY
3 = Z GNIAZDEM DO ZAWORU ODCIĄŻAJĄCEGO / VENTING VALVE READY
4 = Z ZAWOREM PRZELEWOWYM I GNIAZDEM DO ZAWORU ODCIĄŻAJĄCEGO / WITH R.V. AND V.V. READY
5 = Z ZAWOREM PRZELEWOWYM I ODCIĄŻAJĄCYM / WITH R.V. AND V.V.
6 = Z GNIAZDEM DO ZAWORU PRZELEWOWEGO I ODCIĄŻAJĄCEGO / V.V. READY AND R.V. READY

0 = BEZ ZAWORU PRZELEWOWEGO / WITHOUT R.V.
1 = 5 - 50 BAR
2 = 20 - 110 BAR
3 = 50 - 220 BAR
4 = 100 - 350 BAR
5 = 100 - 420 BAR

0 = BEZ ZAWORU PRZELEWOWEGO / WITHOUT RELIEF VALVE
H = ŚRUBA REGULACYJNA SZEŚCIOKĄTNA / HEX. HEAD SCREW
K = REGULACJA POKRĘTŁEM / KNOB
C = KAPTUREK / COVER CAP
I = BRAK REGULACJI / NOT ADJUSTABLE

ZAWÓR ODCIĄŻAJĄCY / VENTING VALVE
000 = BEZ ZAWORU ODCIĄŻAJĄCEGO / WITHOUT V.V.
TS2 = NORMALNIE OTWARTY / NORMALLY OPEN

USZCZELNIENIE / SEALS
N = NBR
V = VITON

TYP WTYCZKI / CONNECTOR TYPE
0 = BEZ CEWKI / WITHOUT COIL
C = CAVI / LEADS
D = DIN 43650
G = DEUTSCH DT04 - 2P
A = AMP JUNIOR

NAPIĘCIE / TENSIONE / VOLTAGE
000 = BEZ CEWKI / WITHOUT COIL
D12 = 12VDC
D24 = 24VDC
220 = 220 RAC

ZAWÓR ODCIĄŻAJĄCY / VENTING VALVE
0 = BEZ RĘCZNEGO PRZESTEROWANIA / NO MANUAL OVERRIDE
3 = PRZESTEROWANIE SZPILKĄ / PUSH PIN
4 = PRZESTEROWANIE PRZYCISKIEM / PUSH BOTTOM
5 = PRZESTEROWANIE KLUCZEM IMBUSOWYM / HEX. ALLEN

E_10-00-10

Płyta zaślepiająca NG10 (CETOP 5)

END PLATE CETOP 5

OPIS TECHNICZNY / TECHNICAL DESCRIPTION

SCHEMAT HYDRAULICZNY / HYDRAULIC DIAGRAM

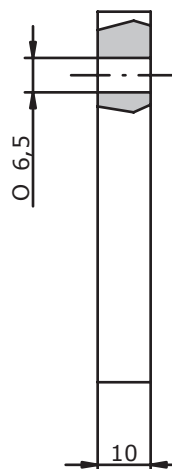
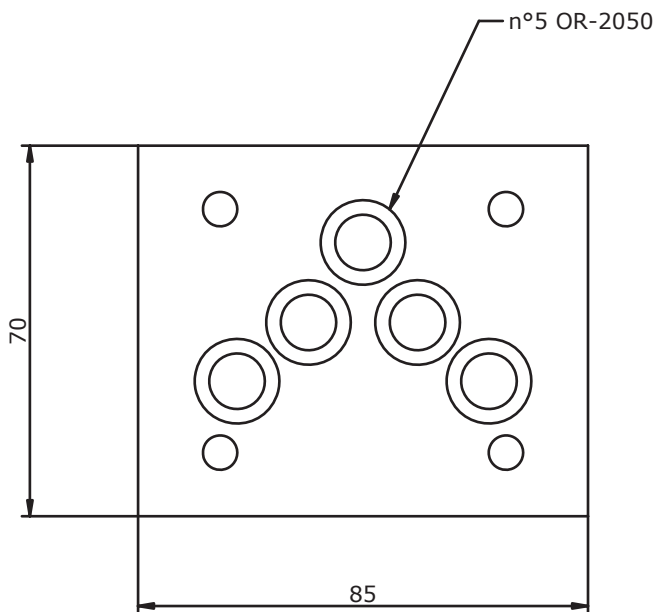
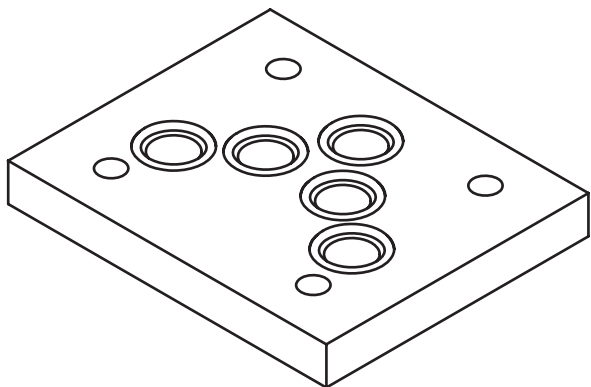

KOD ZAMÓWIENIA - ORDERING CODE

E_10-00-10

S = STAL / STEEL

E_610-10-__

Płyta przyłączeniowa NG10 (CETOP 5) do przekaźnika ciśnienia

PACKING PLATE CETOP 5 FOR PRESSURE SWITCH

OPIS TECHNICZNY / TECHNICAL DESCRIPTION

SCHEMAT HYDRAULICZNY / HYDRAULIC DIAGRAM

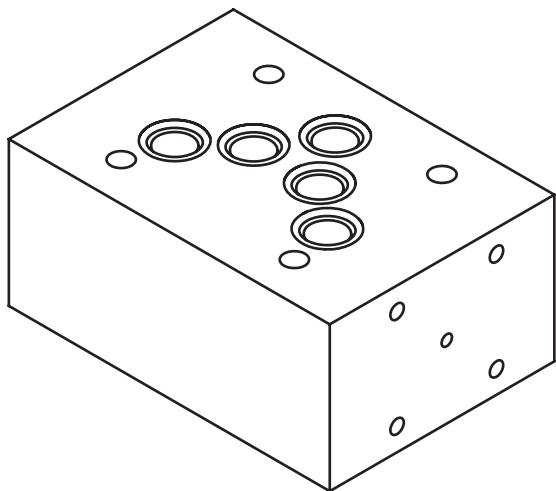

KOD	SCHEMAT / DIAGRAMS
1	A + B STANDARDOWE / STANDARD
2	A STANDARDOWE / STANDARD
3	B STANDARDOWE / STANDARD
4	P + T NA PROŚBĘ / ON REQUEST
5	P NA PROŚBĘ / ON REQUEST
6	T NA PROŚBĘ / ON REQUEST
7	P + P NA PROŚBĘ / ON REQUEST

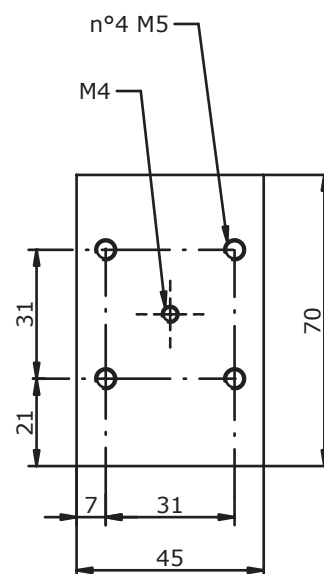
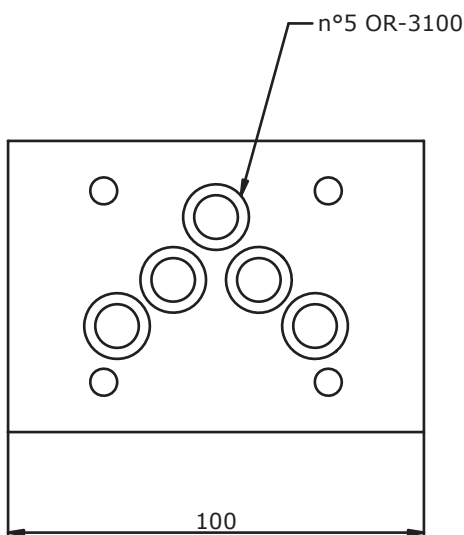
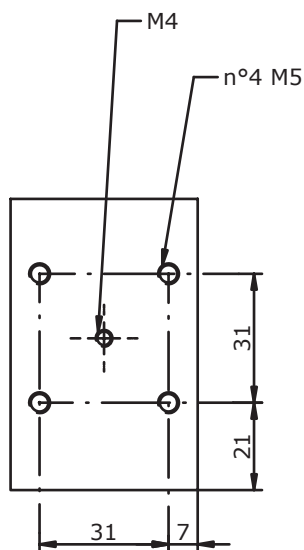
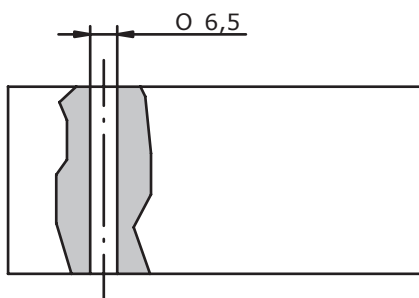

KOD ZAMÓWIENIA - ORDERING CODE

E_610-10-__

S = STAL / STEEL
A = ALUMINIUM / ALUMINUM

SCHEMAT / SEE DIAGRAMS

E_610-05-__

Płyta redukcyjna NG10 / NG6 (CETOP 5 / CETOP 3)

REDUCTION PLATE CETOP 5 / CETOP 3

OPIS TECHNICZNY / TECHNICAL DESCRIPTION

SCHEMAT HYDRAULICZNY / HYDRAULIC DIAGRAM

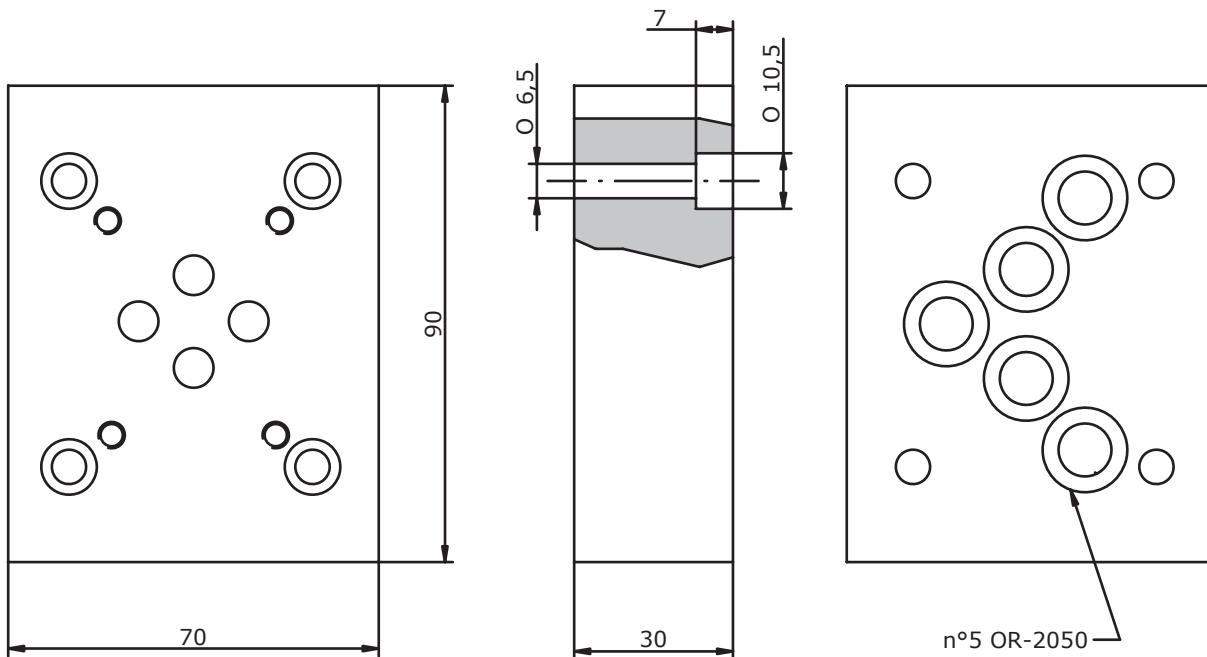
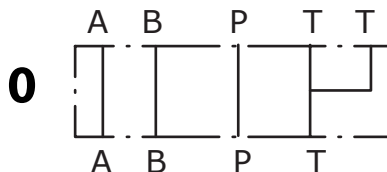
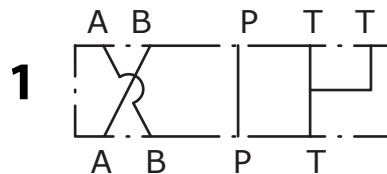
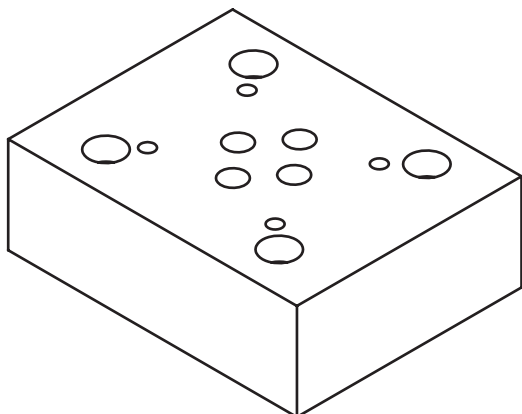

KOD ZAMÓWIENIA - ORDERING CODE

E_610-05-__

S = STAL / STEEL
A = ALUMINIUM / ALUMINUM

SCHEMAT / SEE DIAGRAMS

E_10-02-

Płyta przyłączeniowa NG10 (CETOP 5) porty A-B-P-T z boku

SUBPLATE CETOP 5 WITH PORTS A-B-P-T ON SIDE

OPIS TECHNICZNY / TECHNICAL DESCRIPTION

SCHEMAT HYDRAULICZNY / HYDRAULIC DIAGRAM

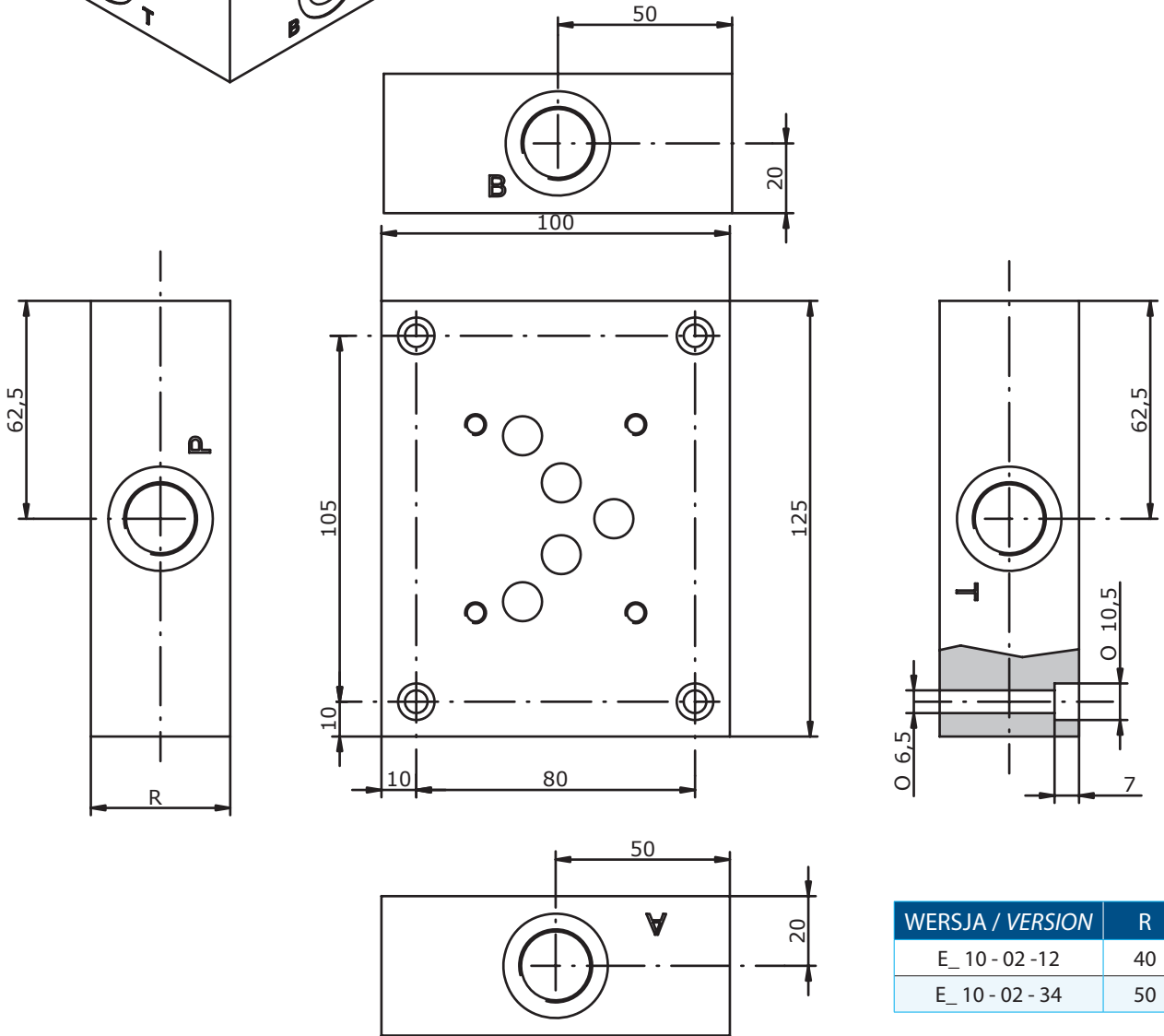
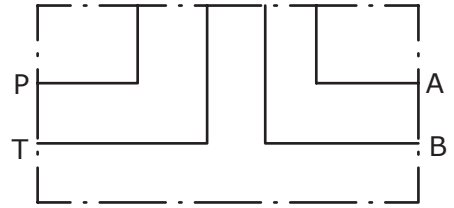
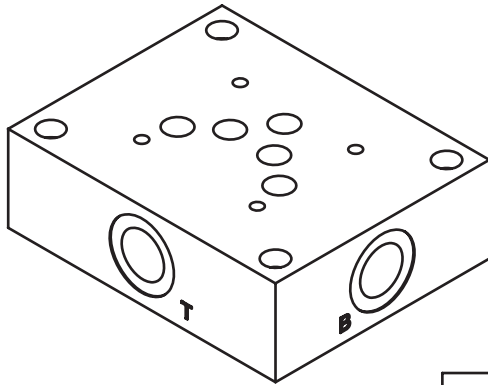

WERSJA / VERSION	R
E_10-02-12	40
E_10-02-34	50

KOD ZAMÓWIENIA - ORDERING CODE

E_10-02-

S = STAL / STEEL
A = ALUMINIUM / ALUMINUM

12 = BSP 1/2G
34 = BSP 3/4G

E_10-09 -

Płyta przyłączeniowa NG10 (CETOP 5) porty A-B-P-T z boku P-T z dołu

SUBPLATE CETOP 5 WITH PORTS A-B-P-T ON SIDE P-T BACK

OPIS TECHNICZNY / TECHNICAL DESCRIPTION

SCHEMAT HYDRAULICZNY / HYDRAULIC DIAGRAM

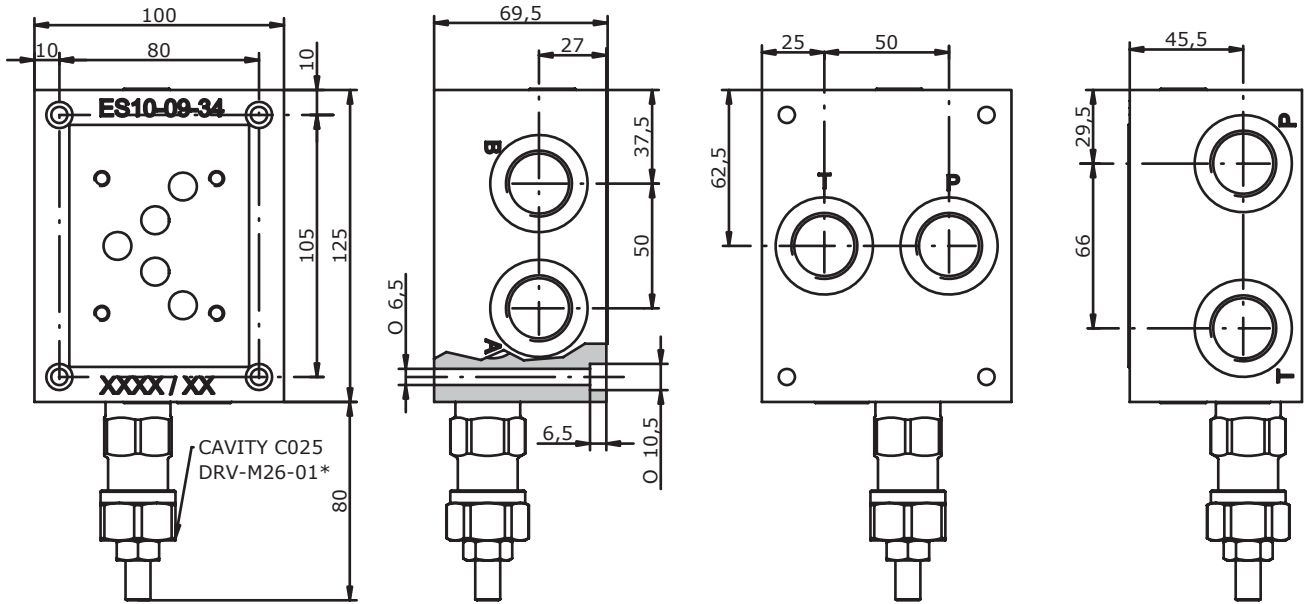
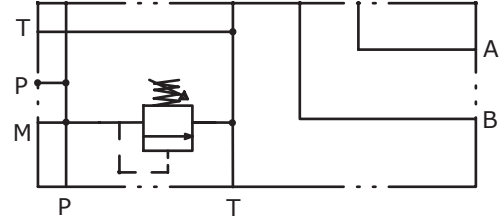
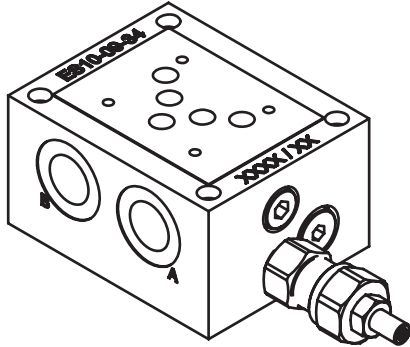

TYPY REGULACJI / REGULATION TYPE

	H	ŚRUBA REGULACYJNA SZEŚCIOKĄTNA / HEXAGONAL HEAD SCREW
	K	REGULACJA POKRĘTŁA / KNOB
	C	KAPTUREK / COVER CAP
	I	BRAK REGULACJI / NON ADJUSTABLE

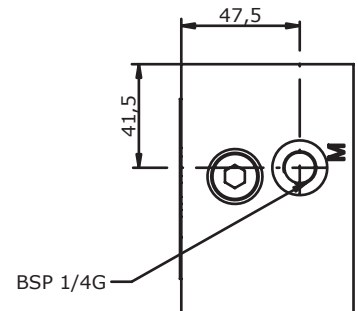
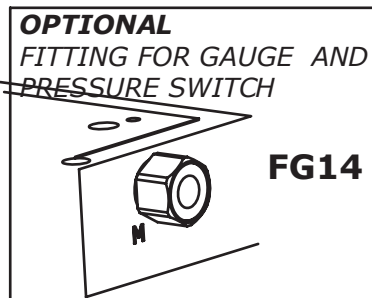

KOD ZAMÓWIENIA - ORDERING CODE

E_10-09 - - - -

S = STAL / STEEL
A = ALUMINIUM / ALUMINUM

12 = BSP 1/2G
34 = BSP 3/4G

0 = BEZ ZAWORU PRZELEWOWEGO / WITHOUT RELIEF VALVE
1 = Z ZAWOREM PRZELEWOWYM / WITH RELIEF VALVE
2 = Z GNIAZDEM DO ZAWORU PRZELEWOWEGO / RELIEF VALVE READY

0 = BEZ ZAWORU PRZELEWOWEGO / WITHOUT R.V.
1 = 5 - 55 BAR
2 = 25 - 110 BAR
3 = 75 - 250 BAR

0 = BEZ ZAWORU PRZELEWOWEGO / WITHOUT RELIEF VALVE
H = ŚRUBA REGULACYJNA SZEŚCIOKĄTNA / HEX. HEAD SCREW
K = REGULACJA POKRĘTŁEM / KNOB
C = KAPTUREK / COVER CAP
I = BRAK REGULACJI / NOT ADJUSTABLE

E_10-05-

Płyta przyłączeniowa NG10 (CETOP 5) porty A-B z dołu P-T z przodu

MONOBLOCK CETOP 5 WITH PORTS A-B BACK P-T CROSSING 3/4"

OPIS TECHNICZNY / TECHNICAL DESCRIPTION

SCHEMAT HYDRAULICZNY / HYDRAULIC DIAGRAM

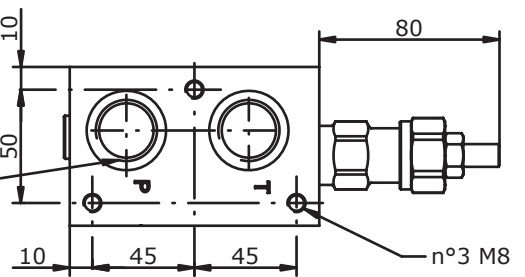
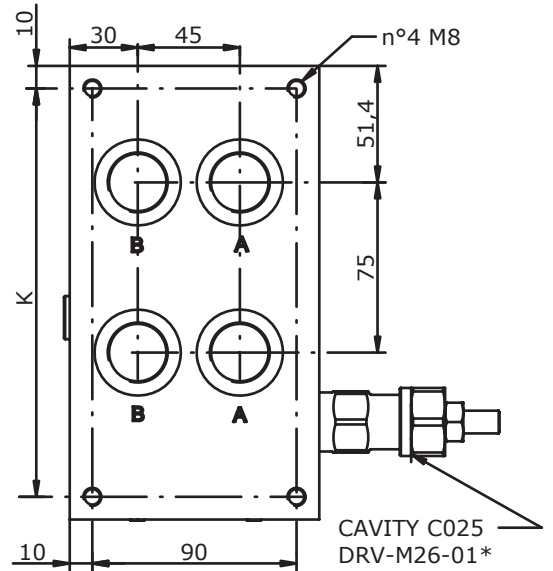
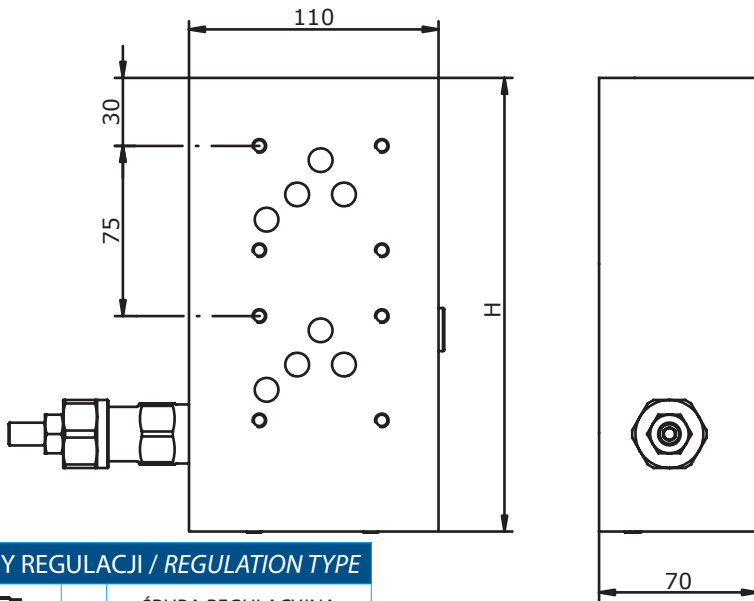
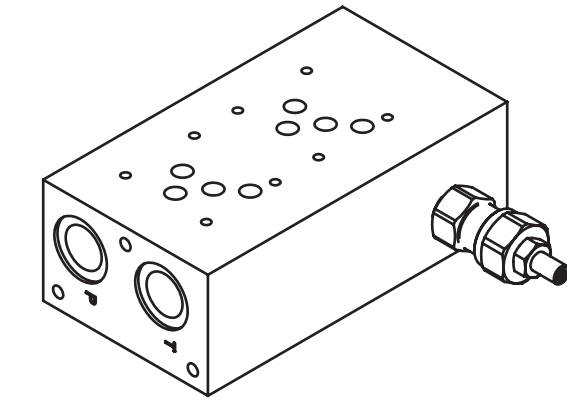
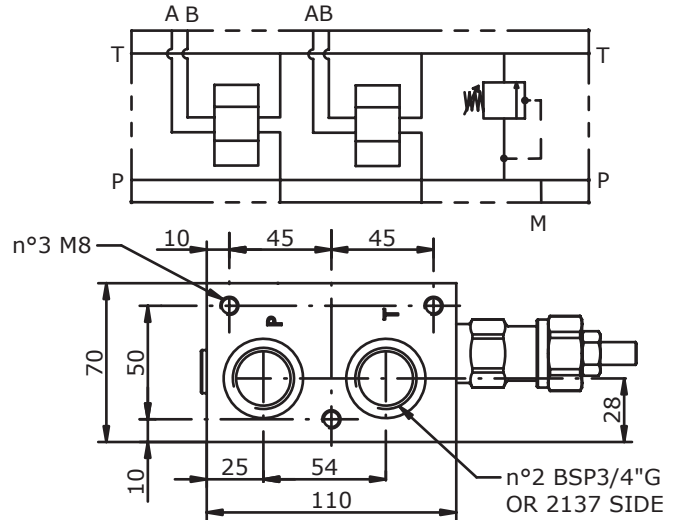

TYPY REGULACJI / REGULATION TYPE

	H	ŚRUBA REGULACYJNA SZEŚCIOKĄTNA / HEXAGONAL HEAD SCREW
	K	REGULACJA POKRĘTŁA / KNOB
	C	KAPTUREK / COVER CAP
	I	BRAK REGULACJI / NON ADJUSTABLE

POS.	02	03	04	05	06
H	200	275	350	425	500
K	180	255	330	405	480

KOD ZAMÓWIENIA - ORDERING CODE

E_10-05- - - - -

S = STAL / STEEL
A = ALUMINIUM / ALUMINUM

12 = BSP 1/2G
34 = BSP 3/4G

ILÓŚĆ SEKCJI / MOUNTING POSITIONS = 02÷06

0 = BEZ ZAWORU PRZELEWOWEGO / WITHOUT RELIEF VALVE
1 = Z ZAWOREM PRZELEWOWYM / WITH RELIEF VALVE
2 = Z GNIAZDEM DO ZAWORU PRZELEWOWEGO / RELIEF VALVE READY

0 = BEZ ZAWORU PRZELEWOWEGO / WITHOUT RELIEF VALVE
H = ŚRUBA REGULACYJNA SZEŚCIOKĄTNA / HEX. HEAD SCREW
K = REGULACJA POKRĘTŁEM / KNOB
C = KAPTUREK / COVER CAP
I = BRAK REGULACJI / NOT ADJUSTABLE

0 = BEZ ZAWORU PRZELEWOWEGO / WITHOUT R.V.
1 = 5 - 55 BAR
2 = 25 - 110 BAR
3 = 75 - 250 BAR

E_10-06-12

Płyta przyłączeniowa NG10 (CETOP 5) porty A-B z boku P-T z przodu

MONOBLOCK CETOP 5 WITH PORTS A-B ON SIDE 1/2" BSP P-T CROSSING 3/4" BSP

OPIS TECHNICZNY / TECHNICAL DESCRIPTION

SCHEMAT HYDRAULICZNY / HYDRAULIC DIAGRAM

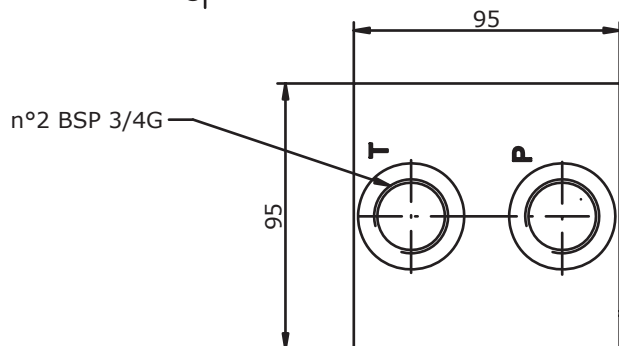
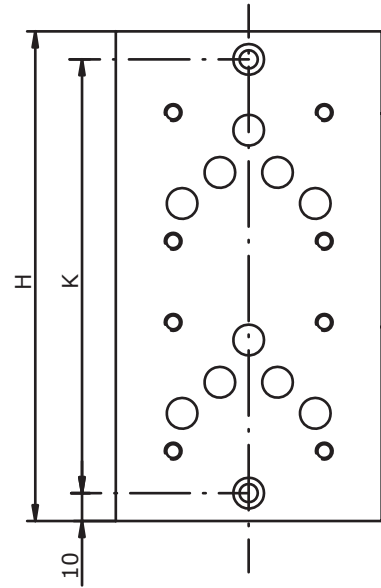
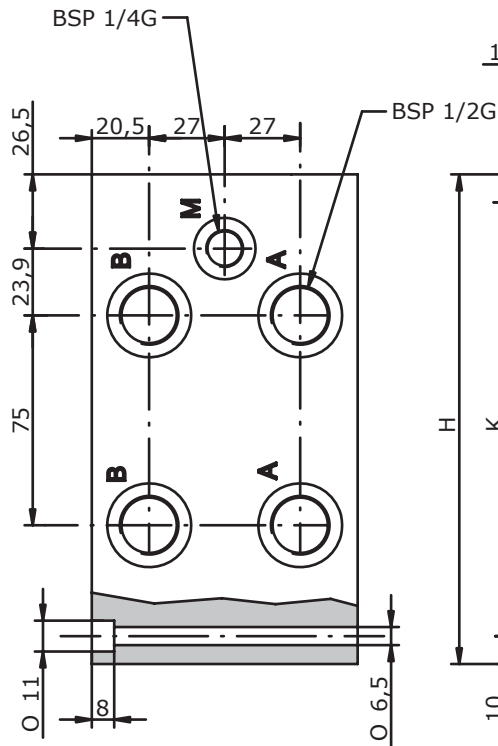
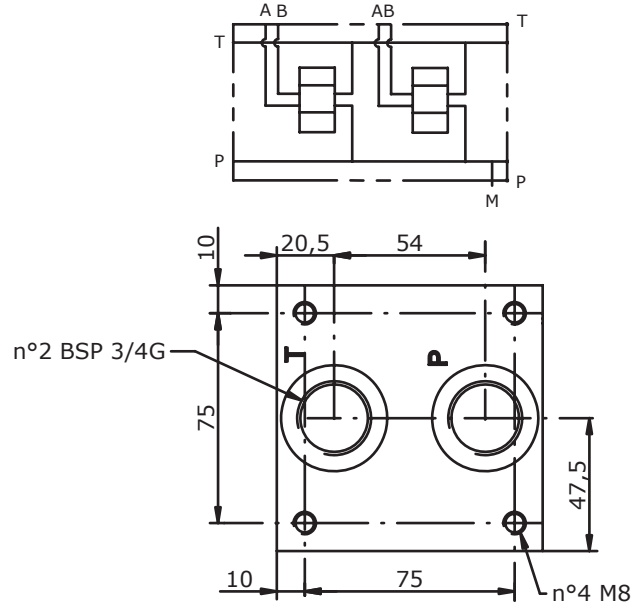
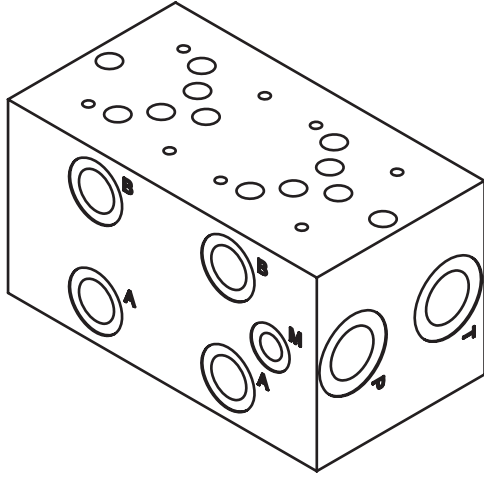

E_10-06-12-_-0







POS.	01	02	03	04	05	06
H	100	175	250	325	400	475
K	84	159	234	309	384	459

E_10-06-12

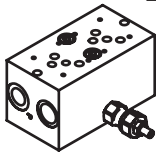
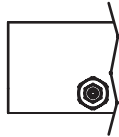
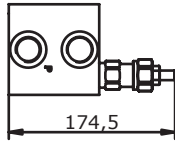
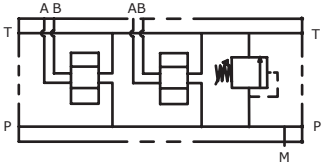
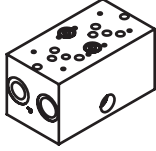
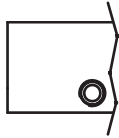
Płyta przyłączeniowa NG10 (CETOP 5) porty A-B z boku P-T z przodu

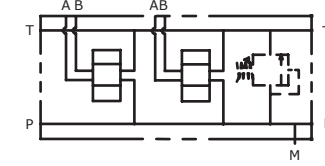
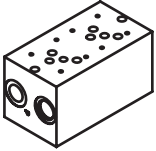
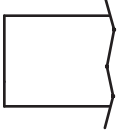
MONOBLOCK CETOP 5 WITH PORTS A-B ON SIDE 1/2" BSP P-T CROSSING 3/4" BSP

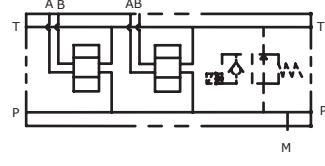
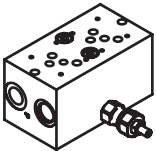
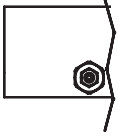
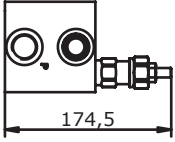
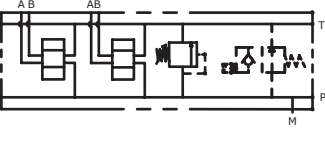
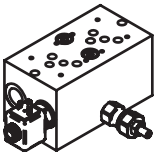
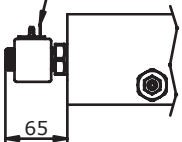
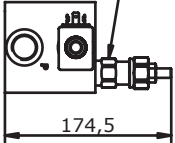
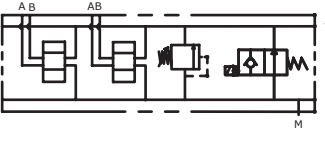
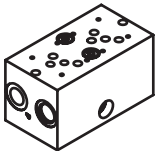
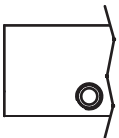
OPIS TECHNICZNY / TECHNICAL DESCRIPTION

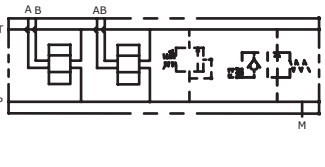
<p>E_10-06-12-__-1</p> 			
<p>E_10-06-12-__-2</p> 			
<p>E_10-06-12-__-3</p> 			
<p>E_10-06-12-__-4</p> 			
<p>E_10-06-12-__-5</p> 	<p>CAVITY C045 SVCP-S12-TS2*</p> 	<p>CAVITY C025 DRV-M26-01*</p> 	
<p>E_10-06-12-__-6</p> 			

KOD ZAMÓWIENIA - ORDERING CODE

E_10-06-12- - - - -

S = STAL / STEEL
A = ALUMINIUM / ALUMINIUM

ILUŚĆ SEKCJI / MOUNTING POSITIONS = 1 ÷ 6

0 = BEZ ZAWORU PRZELEWOWEGO / WITHOUT RELIEF VALVE
1 = Z ZAWOREM PRZELEWOWYM / WITH RELIEF VALVE
2 = Z GNIAZDEM DO ZAWORU PRZELEWOWEGO / RELIEF VALVE READY
3 = Z GNIAZDEM DO ZAWORU ODCIĄŻAJĄCEGO / VENTING VALVE READY
4 = Z ZAWOREM PRZELEWOWYM I GNIAZDEM DO ZAWORU ODCIĄŻAJĄCEGO / WITH R.V. AND V.V. READY
5 = Z ZAWOREM PRZELEWOWYM I ODCIĄŻAJĄCYM / WITH R.V. AND V.V.
6 = Z GNIAZDEM DO ZAWORU PRZELEWOWEGO I ODCIĄŻAJĄCEGO / V.V. READY AND R.V. READY

0 = BEZ ZAWORU PRZELEWOWEGO / WITHOUT R.V.
1 = 5-55 BAR
2 = 25-110 BAR
3 = 75-250 BAR

USZCZELNIENIE / SEALS
N = NBR
V = VITON

TYP WTYCZKI / CONNECTOR TYPE
0 = BEZ CEWKI / WITHOUT COIL
C = CAVI / LEADS
D = DIN 43650
G = DEUTSCH DT04-2P
A = AMP JUNIOR

NAPIĘCIE / TENSIONE / VOLTAGE
000 = BEZ CEWKI / WITHOUT COIL
D12 = 12 VDC
D24 = 24 VDC
D26 = 26 VDC

0 = BEZ ZAWORU PRZELEWOWEGO / WITHOUT RELIEF VALVE
H = ŚRUBA REGULACYJNA SZESZCIOKĄTNA / HEX. HEAD SCREW
K = REGULACJA POKRĘTŁEM / KNOB
C = KAPTUREK / COVER CAP
I = BRAK REGULACJI / NOT ADJUSTABLE

ZAWÓR ODCIĄŻAJĄCY / VENTING VALVE
000 = BEZ ZAWORU ODCIĄŻAJĄCEGO / WITHOUT V.V.
TS2 = NORMALNIE OTWARTY / NORMALLY OPEN

ZAWÓR ODCIĄŻAJĄCY / VENTING VALVE
0 = BEZ RĘCZNEGO PRZESTEROWANIA / NO MANUAL OVERRIDE
2 = PRZESTEROWANIE I SKRĘ / PUSH AND TWIST
4 = PRZESTEROWANIE PRZYCISKIEM / PUSH BOTTON

E_10 - 06 - 34

Płyta przyłączeniowa NG10 (CETOP 5) porty A-B z boku P-T z przodu

SUBPLATE CETOP 5 WITH PORTS A-B ON SIDE P-T CROSSING

OPIS TECHNICZNY / TECHNICAL DESCRIPTION

SCHEMAT HYDRAULICZNY / HYDRAULIC DIAGRAM

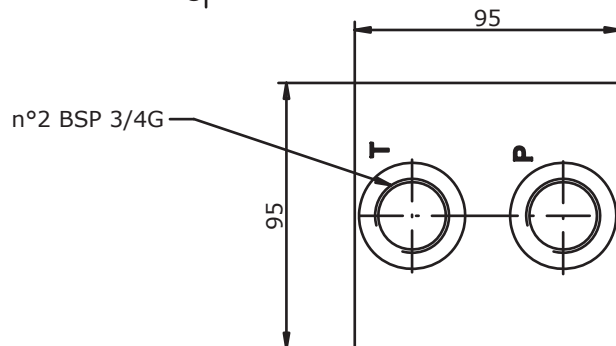
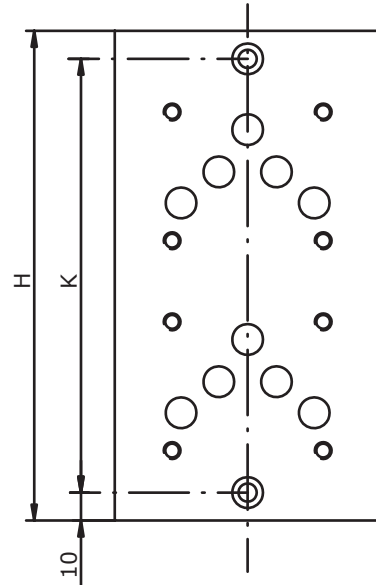
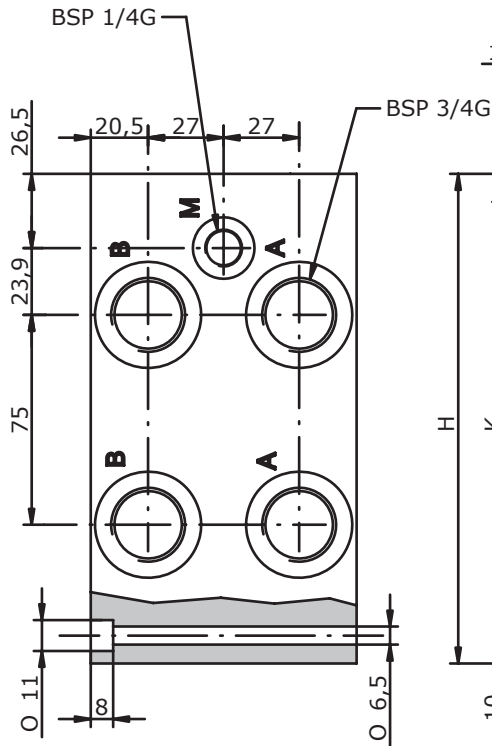
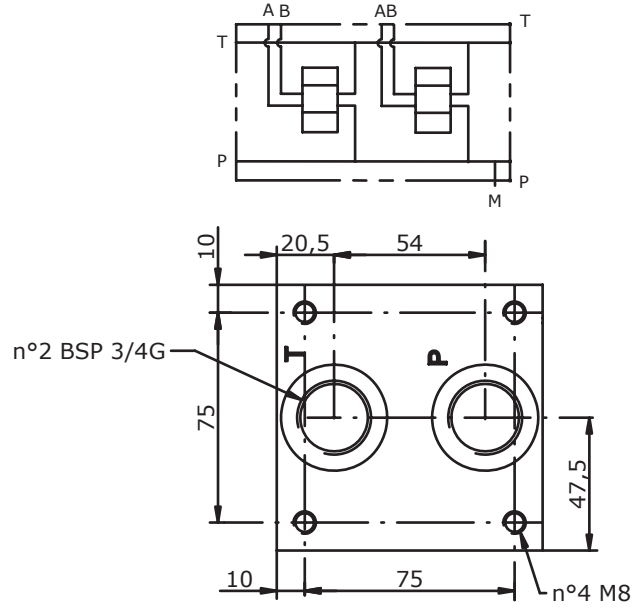
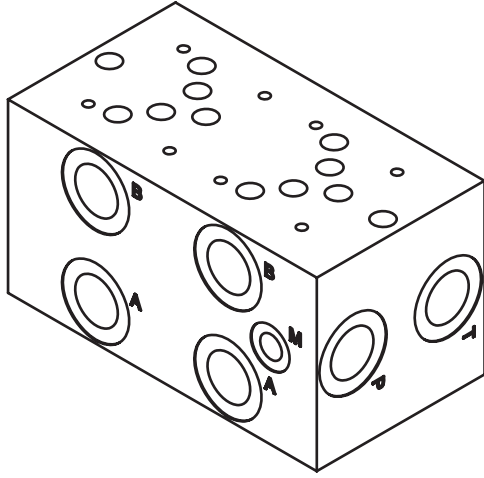

E_10 - 06 - 34 - _ - 0







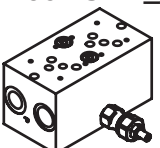

POS.	01	02	03	04	05	06
H	100	175	250	325	400	475
K	84	159	234	309	384	459

E_10 - 06 - 34 -

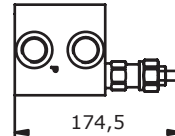
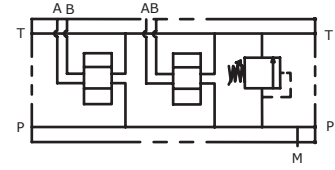
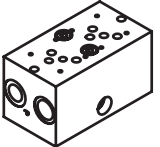
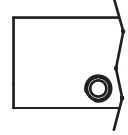
Płyta przyłączeniowa NG10 (CETOP 5) porty A-B z boku P-T z przodu

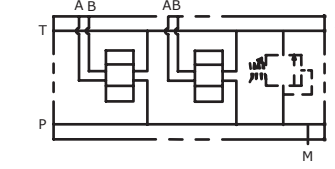
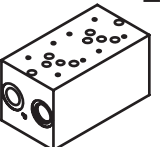
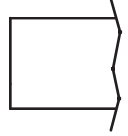
SUBPLATE CETOP 5 WITH PORTS A-B ON SIDE P-T CROSSING

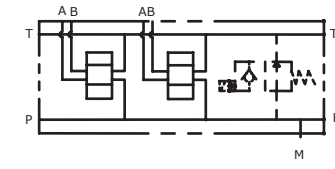
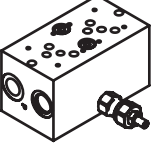
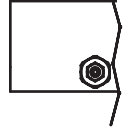
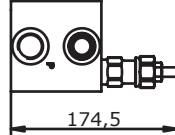
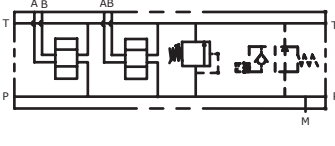
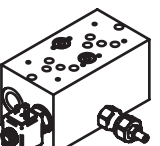
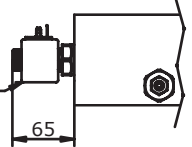
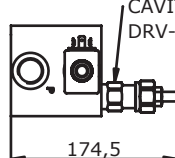
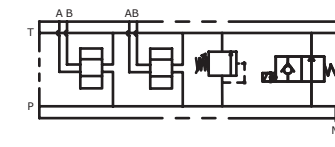
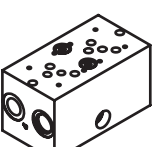
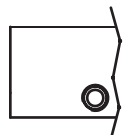
OPIS TECHNICZNY / TECHNICAL DESCRIPTION

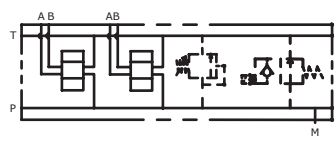
<p>E_10 - 06 - 34 - ___ - 1</p> 		 <p>174,5</p>	
<p>E_10 - 06 - 34 - ___ - 2</p> 			
<p>E_10 - 06 - 34 - ___ - 3</p> 			
<p>E_10 - 06 - 34 - ___ - 4</p> 		 <p>174,5</p>	
<p>E_10 - 06 - 34 - ___ - 5</p> 	 <p>65</p>	 <p>174,5</p>	
<p>E_10 - 06 - 34 - ___ - 6</p> 			

KOD ZAMÓWIENIA - ORDERING CODE

E_10 - 06 - 34 -

S = STAL / STEEL
A = ALUMINIUM / ALUMINUM

IŁOŚĆ SEKCJI / MOUNTING POSITIONS = 1 ÷ 06

0 = BEZ ZAWORU PRZELEWOWEGO / WITHOUT RELIEF VALVE
1 = Z ZAWOREM PRZELEWOWYM / WITH RELIEF VALVE
2 = Z GNIAZDEM DO ZAWORU PRZELEWOWEGO / RELIEF VALVE READY
3 = Z GNIAZDEM DO ZAWORU ODCIĄŻAJĄCEGO / VENTING VALVE READY
4 = Z ZAWOREM PRZELEWOWYM I GNIAZDEM DO ZAWORU ODCIĄŻAJĄCEGO / WITH R.V. AND V.V. READY
5 = Z ZAWOREM PRZELEWOWYM I ODCIĄŻAJĄCYM / WITH R.V. AND V.V.
6 = Z GNIAZDEM DO ZAWORU PRZELEWOWEGO I ODCIĄŻAJĄCEGO / V.V. READY AND R.V. READY

0 = BEZ ZAWORU PRZELEWOWEGO / WITHOUT R.V.
1 = 5 - 55 BAR
2 = 25 - 110 BAR
3 = 75 - 250 BAR

0 = BEZ ZAWORU PRZELEWOWEGO / WITHOUT RELIEF VALVE
H = ŚRUBA REGULACYJNA SZESZCIOKĄTNA / HEX. HEAD SCREW
K = REGULACJA POKRĘTŁEM / KNOB
C = KAPTUREK / COVER CAP
I = BRAK REGULACJI / NOT ADJUSTABLE

ZAWÓR ODCIĄŻAJĄCY / VENTING VALVE
000 = BEZ ZAWORU ODCIĄŻAJĄCEGO / WITHOUT V.V.
TS2 = NORMALNIE OTWARTY / NORMALLY OPEN

USZCZELNIENIE / SEALS
N = NBR
V = VITON

TYP WTYCZKI / CONNECTOR TYPE
0 = BEZ CEWKI / WITHOUT COIL
C = CAVI / LEADS
D = DIN 43650
G = DEUTSCH DT04 - 2P
A = AMP JUNIOR

NAPIĘCIE / TENSIONE / VOLTAGE
000 = BEZ CEWKI / WITHOUT COIL
D12 = 12VDC
D24 = 24VDC
D26 = 26VDC

ZAWÓR ODCIĄŻAJĄCY / VENTING VALVE
0 = BEZ RĘCZNEGO PRZESTEROWANIA / NO MANUAL OVERRIDE
2 = PRZESTEROWANIE I SKRĘ / PUSH AND TWIST
4 = PRZESTEROWANIE PRZYCSKIEM / PUSH BOTTOM

E_16 - 03 - 30

Płyta zaślepiająca NG16 (CETOP 7)

END PLATE CETOP 7

OPIS TECHNICZNY / TECHNICAL DESCRIPTION

SCHEMAT HYDRAULICZNY / HYDRAULIC DIAGRAM

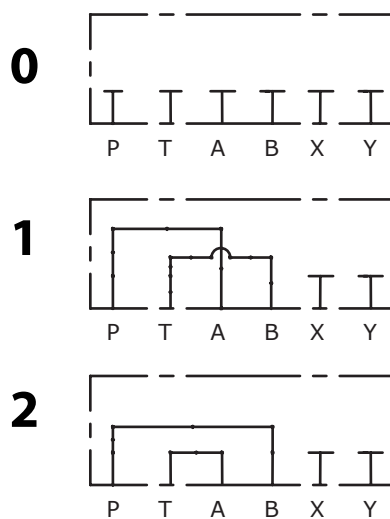
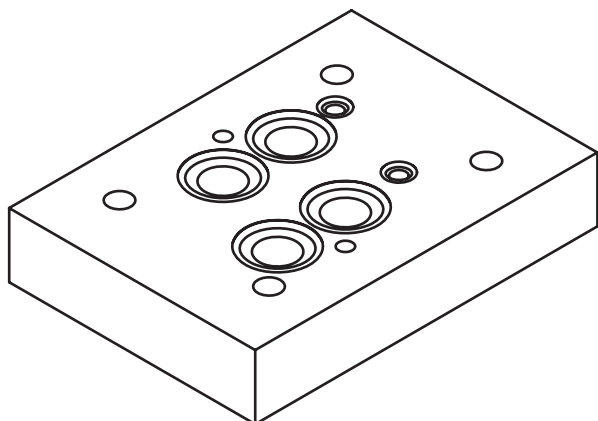

WERSJA / VERSION	R	
E_16-03-30-0	30	STANDARD
E_16-03-30-1	45	NA PROŚBĘ
E_16-03-30-2	30	NA PROŚBĘ

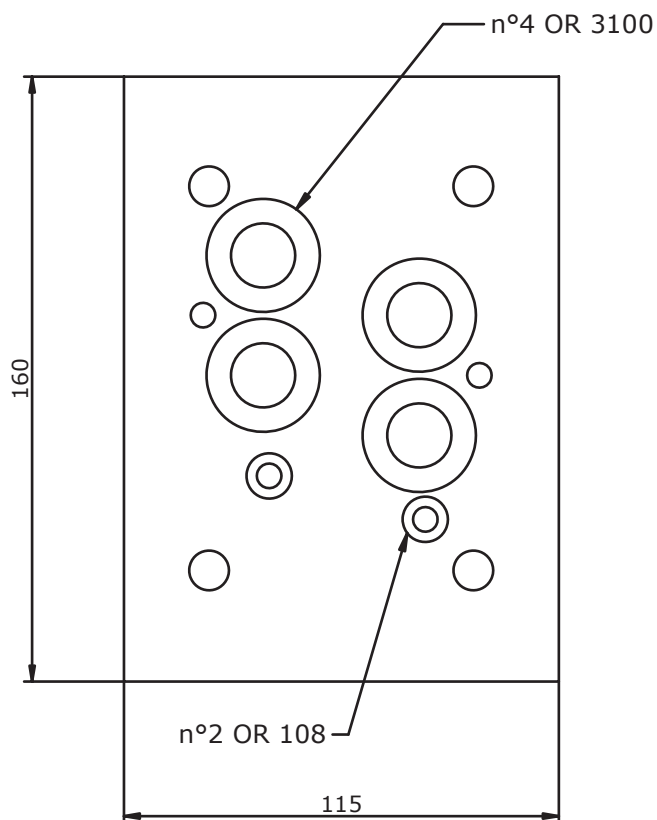
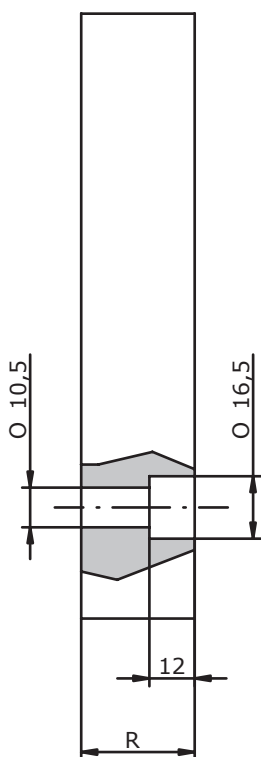

KOD ZAMÓWIENIA - ORDERING CODE

E_16 - 03 - _30 - _

S = STAL / STEEL
A = ALUMINIUM / ALUMINUM

SCHEMAT / SEE DIAGRAMS

E_16 - 08 - 00

Płyta redukcyjna NG16 / NG10 (CETOP 7 / CETOP 5)

REDUCTION PLATE CETOP 7 / CETOP 5

OPIS TECHNICZNY / TECHNICAL DESCRIPTION

SCHEMAT HYDRAULICZNY / HYDRAULIC DIAGRAM

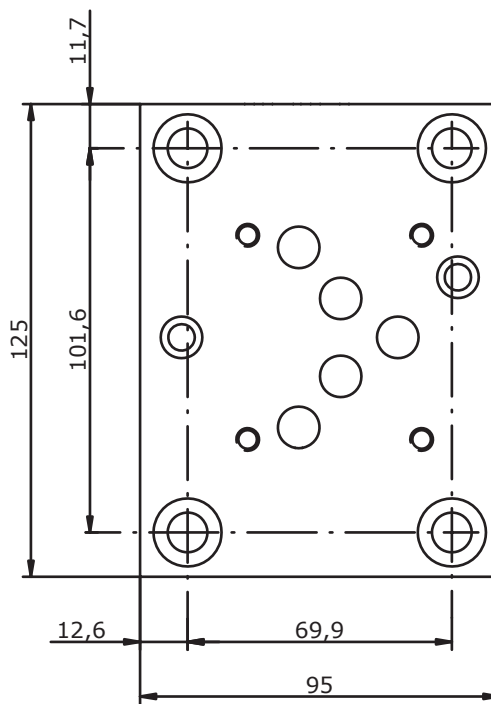
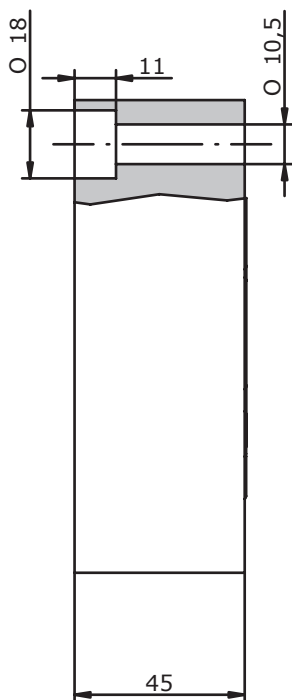
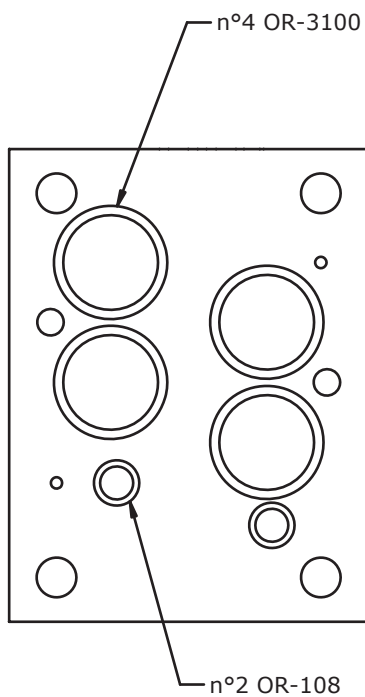
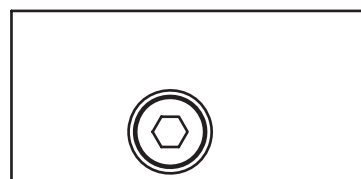
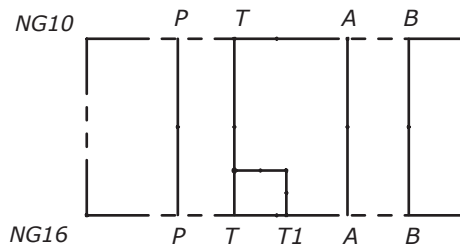
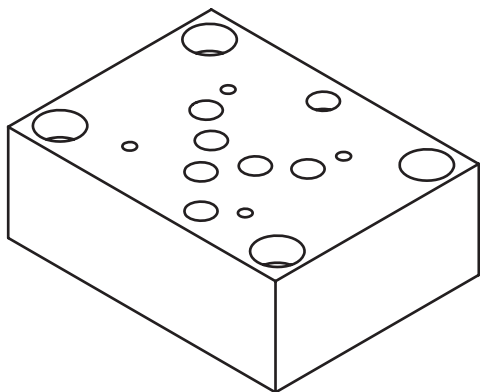

KOD ZAMÓWIENIA - ORDERING CODE

E_16 - 08 - 00

S = STAL / STEEL
A = ALUMINIUM / ALUMINUM

E_16-02-__

Płyta przyłączeniowa NG16 (CETOP 7) porty A-B-P-T z boku

SUBPLATE CETOP 7 WITH PORTS A-B-P-T ON SIDE

OPIS TECHNICZNY / TECHNICAL DESCRIPTION

SCHEMAT HYDRAULICZNY / HYDRAULIC DIAGRAM

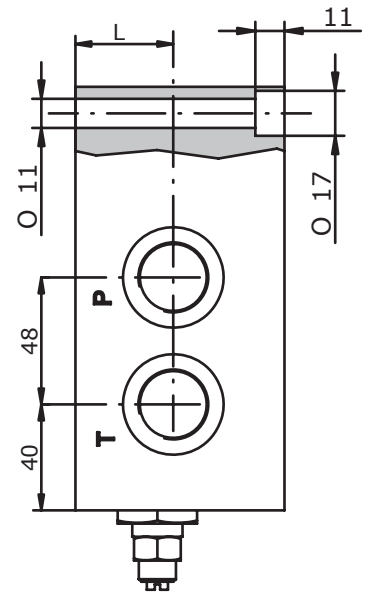
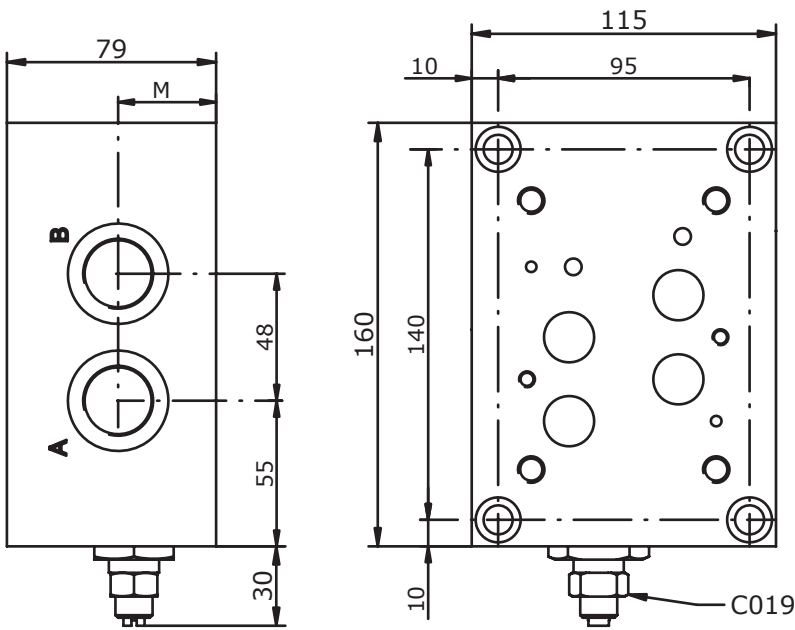
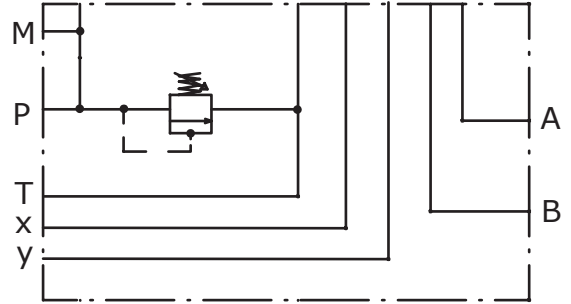
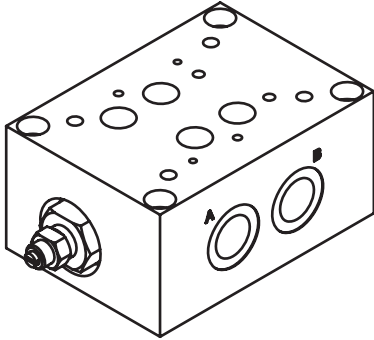

WERSJA /VERSION	L	M
E_16-02-34	37	37
E_16-02-100	37	40
E_16-02-114	33	33

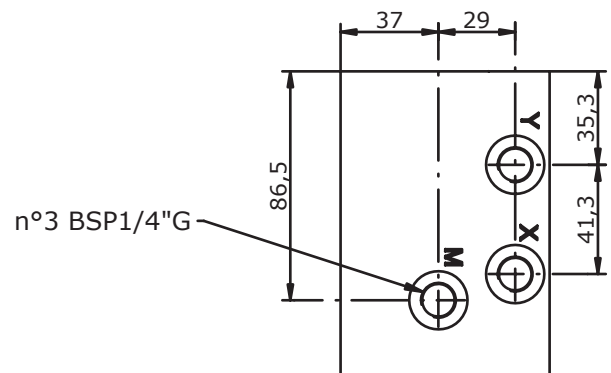

KOD ZAMÓWIENIA - ORDERING CODE

E_16-02-__-__-__

S = STAL / STEEL

A = ALUMINIUM / ALUMINUM

34 = BSP 3/4

100 = BSP 1G

114 = BSP 1.1/4G

0 = BEZ ZAWORU PRZELEWOWEGO / WITHOUT R.V.

1 = 0-250 BAR

2 = 200-350 BAR

0 = BEZ ZAWORU PRZELEWOWEGO / WITHOUT RELIEF VALVE

1 = Z ZAWOREM PRZELEWOWYM / WITH RELIEF VALVE

2 = Z GNIAZDEM DO ZAWORU PRZELEWOWEGO / RELIEF VALVE READY

Dział sprzedaży:

+48 33 829 56 63

+48 33 829 56 79



HYDRO ZNPHS Sp. z o.o.

43-382 Bielsko-Biała
ul. Strażacka 60, Polska